

Copyright © 1966, by the author(s).  
All rights reserved.

Permission to make digital or hard copies of all or part of this work for personal or classroom use is granted without fee provided that copies are not made or distributed for profit or commercial advantage and that copies bear this notice and the full citation on the first page. To copy otherwise, to republish, to post on servers or to redistribute to lists, requires prior specific permission.

ON BOUNDED-INPUT - BOUNDED-OUTPUT STABILITY OF  
A CERTAIN CLASS OF NONLINEAR SAMPLED-DATA SYSTEMS

by

A. R. Bergen

R. P. Iwens

Memorandum ERL-M159

22 April 1966

ELECTRONICS RESEARCH LABORATORY

College of Engineering  
University of California, Berkeley  
94720

Manuscript submitted: 13 April 1966

The research reported herein was supported by the Air Force Office of Scientific Research under Grants AF-AFOSR-292-66 and AF-AFOSR-230-66.

## ABSTRACT

A sufficient condition for absolute stability in the bounded-input - bounded-output sense for a class of nonlinear sampled-data systems is obtained. The stability theorem yields a Popov-type frequency domain test on the linear plant. The obtained criterion is identical to the criterion that establishes absolute stability for the same class of autonomous nonlinear sampled-data systems.

# On Bounded-Input - Bounded-Output Stability of a Certain Class of Nonlinear Sampled-Data Systems

## I. Introduction

The stability of nonlinear sampled-data feedback systems has been the object of intensive research in the past few years. However, the main concern has been for autonomous systems. Tsypkin,<sup>1,2</sup> Jury and Lee,<sup>3,4,5</sup> Gibson,<sup>6</sup> Pearson,<sup>6,7</sup> Szegö,<sup>7,8</sup> and others obtained criteria for absolute stability of certain classes of nonlinear sampled-data feedback systems.

Another important and very practical type of stability is absolute stability in the bounded-input - bounded-output sense (b. i. b. o.). The object of this paper is to prove that stability tests for a class of autonomous nonlinear sampled-data systems also establish absolute stability in the b. i. b. o. sense. Recently, Sandberg,<sup>9</sup> and Bergen, Iwens and Rault<sup>10</sup> proved similar results for continuous nonlinear feedback systems.

The notation and terminology in this paper follow essentially those used by Jury,<sup>11,12</sup> Jury and Lee,<sup>3,4</sup> and Aizerman and Gantmacher.<sup>13</sup>

Notation. For convenience, denote in general:

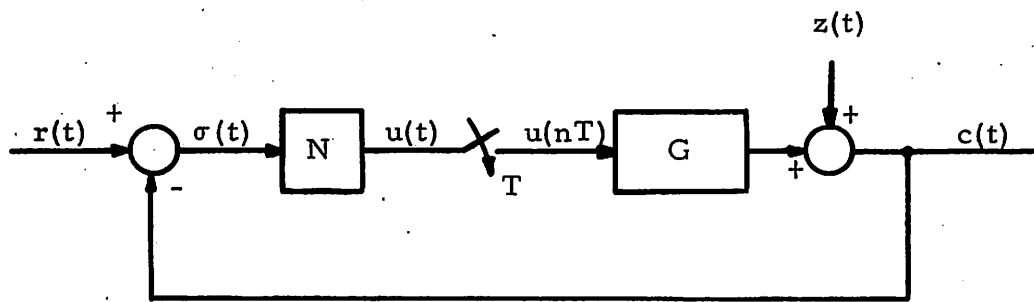

Fig. 1. System S.

$f(n) \triangleq f(nT)$  the value of  $f(t)$  at the  $n$ th sampling instant, for a sampler with a sampling rate of  $1/T$ .

$\nabla f(n) \triangleq f(n) - f(n-1)$ , the backward difference.

$e^{j\bar{\omega}} \triangleq e^{j\omega T}$ , for values of  $z = e^{sT}$  on the unit circle.

All functions of discrete variables appearing in this paper are identically zero for negative arguments.

## II. Description of System

Consider the single input, single output, sampled-data feedback system  $S$  shown in Fig. 1. The nonlinear gain element  $N$  is memoryless, the linear plant  $G$  is nonanticipative, time-invariant and completely controllable and observable.

Assumption 1. The nonlinear element  $N$  is characterized by a piecewise continuous, integrable function  $\varphi(\cdot)$  defined on  $(-\infty, +\infty)$  satisfying

$$0 \leq \frac{\varphi(\sigma)}{\sigma} \leq k < \infty, \quad \forall \sigma \neq 0 \quad (1)$$

$$\varphi(0) = 0 \quad (2)$$

and

$$0 \leq \frac{d\varphi}{d\sigma} \leq \infty \quad (3)$$

Inequality (3) is equivalent to saying that  $\varphi(\sigma)$  is a monotone nonlinearity.

For ease of notation, let  $\varphi(\sigma(t)) = u(t)$ .

Assumption 2. The linear plant is characterized by its transfer function  $G(s)$ , which has no poles in the right half  $s$ -plane. Hold circuits and any continuous or discrete compensation networks may be thought of as being included in  $G(s)$ . However,  $G(s)$  must have a  $z$ -transform,  $Z[G(s)] = G^*(z)$ , which is a rational fraction in  $z$  whose numerator polynomial is at most of the same degree as the denominator. Furthermore,  $G^*(z)$  has poles only inside the unit circle (principal cases), or has some poles on the unit circle (particular cases), but is analytic everywhere outside the unit circle.

$z(t)$  is the zero input response of the linear plant.

Assumption 3. The input signal,  $r(t)$ , to the system  $S$  is bounded for all  $t \geq 0$ .

### III. Main Results

Theorem 1. For the system  $S$  satisfying the previous assumptions to be absolutely b. i. b. o. stable in the sector  $[0, k]$  for the principal case and in the sector  $[\epsilon, k]$  for the particular cases ( $\epsilon > 0$  arbitrarily small), it is sufficient that there exist a finite nonnegative real number  $q$  such that for all  $|z| = 1$  the following inequality is satisfied.

$$\operatorname{Re} \left\{ \left[ 1 + q \left( \frac{z-1}{z} \right) \right] G^*(z) \right\} + \frac{1}{k} \geq \delta > 0 \quad (P)$$



In addition, for particular cases, the conditions for stability-in-the-limit\* must be satisfied.

It is noted that Theorem 1 is identical to the result obtained by Jury and Lee<sup>4</sup> for stability of the autonomous system S.

Remarks. Without loss of generality Theorem 1 need only be proved for

- (i) principal cases of  $G^*(z)$
- (ii) the nonlinearity  $\varphi(\sigma)$  in the reduced sector  $[\epsilon, k - \epsilon]$ , i. e.,  
$$\epsilon \leq \frac{\varphi(\sigma)}{\sigma} \leq k - \epsilon, \quad \forall \sigma \neq 0, \text{ where } \epsilon > 0 \text{ is arbitrarily small.}$$

These remarks will be justified in a similar manner as Aizerman and Gantmacher<sup>13</sup> justified them for the stability of autonomous, continuous, nonlinear feedback systems.

To justify (i), assume that  $G^*(z)$  is a particular case satisfying all the conditions of Theorem 1. Make the change of variable

$$\varphi(\sigma) = \tilde{\varphi}(\sigma) + \epsilon \sigma \tag{4}$$

which transforms the system S into an equivalent system  $\tilde{S}$  shown in

---

\* These conditions require that the system S of Fig. 1 be asymptotically stable for a linear gain  $\varphi(\sigma) = \epsilon \sigma$ ,  $\epsilon > 0$ , arbitrarily small. This is a linear problem which has been extensively treated by Jury<sup>11, 12</sup> and others. For instance, root locus techniques could be used to check whether the conditions for stability-in-the-limit are satisfied.

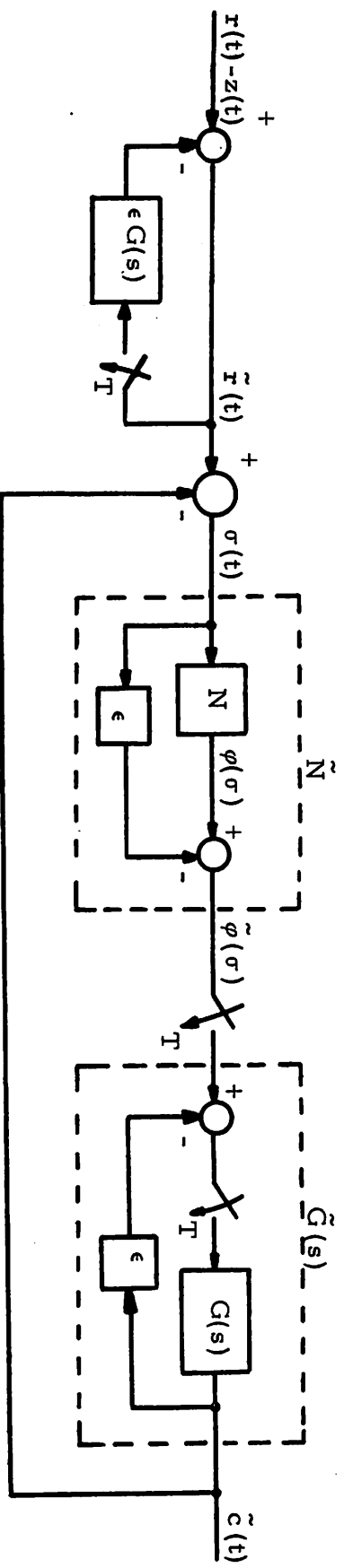

Fig. 2. Transformed system  $\tilde{S}$ .

Fig. 2. Note that the quantity  $\sigma(t)$  remains unchanged under this transformation and that if  $\varphi(\sigma)$  is contained in the sector  $[\epsilon, k]$ , then  $\tilde{\varphi}(\sigma)$  is contained in  $[0, k - \epsilon]$ . Also, the conditions of Theorem 1 imply that  $Z[\tilde{G}(s)] = \tilde{G}^*(z) = \frac{G^*(z)}{1 + \epsilon G^*(z)}$  has all its poles inside the unit circle and therefore is a principal case. This in turn implies that  $\tilde{r}(t)$  (see Fig. 2) is bounded for all  $t \geq 0$ . Consider for all  $z$  on the unit circle, i. e.,  $z = e^{j\bar{\omega}}$ ,  $-\pi \leq \bar{\omega} \leq \pi$ ,

$$\begin{aligned} \operatorname{Re} \left\{ \left[ 1 + q \left( \frac{z-1}{z} \right) \right] \tilde{G}^*(z) + \frac{1}{k-\epsilon} \right\} \\ = \frac{1}{|1 + \epsilon G^*|^2} \operatorname{Re} \left\{ \left[ 1 + q \left( \frac{z-1}{z} \right) \right] G^*(z) + \frac{1}{k} \right\} \\ + \epsilon q (1 - \cos \bar{\omega}) \left| \frac{G^*}{1 + \epsilon G^*} \right|^2 + \frac{k\epsilon}{k-\epsilon} \left| \frac{G^* + \frac{1}{k}}{1 + \epsilon G^*} \right|^2 \end{aligned} \quad (5)$$

It is clear from (5) that satisfaction of (P) in Theorem 1 implies that there exists  $\tilde{\delta} > 0$  such that\*

$$\operatorname{Re} \left\{ \left[ 1 + q \left( \frac{z-1}{z} \right) \right] \tilde{G}^*(z) \right\} + \frac{1}{k-\epsilon} \geq \tilde{\delta} > 0, \quad \forall |z| = 1 \quad (6)$$

If Theorem 1 has been proved for principal cases, then (6) establishes

\* If  $G^*(z)$  has a pole at  $z = e^{j\bar{\omega}_0}$ , then the r. h. s. of (5) at  $\bar{\omega} = \bar{\omega}_0$  becomes  $(1 - \cos \bar{\omega}_0) q / \epsilon + k / [\epsilon(k - \epsilon)] > 0$ ,  $-\pi \leq \bar{\omega}_0 \leq \pi$ .

stability of the transformed system  $\tilde{S}$  in the sector  $[0, k - \epsilon]$ . The original system is then stable in the sector  $[\epsilon, k]$ , which was to be shown .

To justify (ii) assume that  $G^*(z)$  is a principal case and make the transformation

$$\varphi(\sigma) = \varphi_\epsilon(\sigma) - \epsilon \sigma \quad (7)$$

The nonlinearity  $N_\epsilon$  of the transformed system  $S_\epsilon$  is characterized by  $\varphi_\epsilon(\sigma)$  in the sector  $[\epsilon, k + \epsilon]$ , and  $Z[G_\epsilon(s)] = G_\epsilon^*(z) = \frac{G^*(z)}{1 - \epsilon G^*(z)}$ . For a sufficiently small  $\epsilon > 0$ ,  $G_\epsilon^*(z)$  will be a principal case. It can be shown, by using (5) with a negative  $\epsilon$ , that satisfaction of (P) in Theorem 1 implies that there exists a  $\delta_\epsilon$ ,  $0 < \delta_\epsilon < \delta$ , such that the inequality

$$\text{Re} \left\{ \left[ 1 + q \left( \frac{z-1}{z} \right) \right] G_\epsilon^*(z) \right\} + \frac{1}{k+2\epsilon} \geq \delta_\epsilon > 0, \quad \forall |z| = 1 \quad (8)$$

is satisfied for a sufficiently small  $\epsilon > 0$ . Hence, if Theorem 1 has been proved for principal cases of  $G^*(z)$  with the nonlinearity in a reduced sector  $[\epsilon, k - \epsilon]$ , then (8) establishes stability of  $S_\epsilon$  in the sector  $[\epsilon, k + \epsilon]$ . The original system  $S$  is then stable in the sector  $[0, k]$ , which was to be shown.

Auxiliary Lemmas. The proof of Theorem 1 uses two lemmas, one of which is closely related to a well-known lemma from the frequency

domain analysis in the V. M. Popov Theorem.<sup>13</sup> The other is the main contribution of this paper.

Lemma 1. If the three real functions of the discrete variable  $n$ ,  $f_1(n)$ ,  $f_2(n)$ ,  $f_3(n)$  tend to zero for  $n \rightarrow \infty$  not slower than an exponential and if their  $z$ -transforms are related by

$$F_1^*(z) = H^*(z) F_3^*(z) + F_2^*(z)$$

where

$$\operatorname{Re} H^*(z) \geq \beta > 0, \quad \forall |z| = 1$$

then

$$-\sum_{n=0}^{\infty} f_1(n) f_3(n) \leq \frac{1}{4\beta} \sum_{n=0}^{\infty} [f_2(n)]^2$$

Main Lemma. If the system  $S$  satisfies all the conditions of Theorem 1 then the following inequality holds for sufficiently small  $\alpha > 0$

$$\left( \sum_{j=0}^n e^{2\alpha j} u^2(j) \right)^{1/2} \leq \left( \frac{1}{\delta^2} \sum_{j=0}^n e^{2\alpha j} [r(j) - z(j) + q(\nabla r(j) - \nabla z(j))]^2 \right)^{1/2} \quad \forall n \geq 0 \quad (L)$$

Proof of Theorem 1. Referring to the remarks, we need only prove Theorem 1 for principal cases of  $G^*(z)$ . It may also be assumed that

$\varphi(\sigma)$  in  $[0, k]$  is contained in the reduced sector  $[\epsilon, k - \epsilon]$ . Denote  $g(n)$  as the inverse z-transform of  $G^*(z)$ . At the  $n$ th sampling instant the system S yields the relationship

$$\sigma(n) = r(n) - z(n) - \sum_{j=0}^n g(n-j) u(j) \quad (9)$$

or equivalently,

$$\sigma(n) = r(n) - z(n) - \sum_{j=0}^n e^{\alpha(n-j)} g(n-j) e^{-\alpha(n-j)} u(j) \quad (10)$$

Using the triangle inequality and the Schwarz inequality, we obtain

$$|\sigma(n)| \leq |r(n) - z(n)| + \left( \sum_{\ell=0}^{\infty} e^{2\alpha\ell} g^2(\ell) \right)^{1/2} e^{-\alpha n} \left( \sum_{j=0}^n e^{2\alpha j} u^2(j) \right)^{1/2} \quad (11)$$

Using inequality (L) of the Main Lemma yields

$$|\sigma(n)| \leq |r(n) - z(n)| + \left( \sum_{\ell=0}^{\infty} e^{2\alpha\ell} g^2(\ell) \right)^{1/2} \cdot \frac{1}{\delta} \left( \sum_{j=0}^n e^{-2\alpha(n-j)} [r(j) - z(j) + q(\nabla r(j) - \nabla z(j))]^2 \right)^{1/2} \quad (12)$$

Since  $G^*(z)$  is a principal case, there exist positive constants  $K_1, K_2$ , such that  $|g(n)| \leq K_1 e^{-K_2 n}, \forall n \geq 0$ . Therefore there exists an  $\alpha$ ,  $0 < \alpha < K_2$ , such that  $\sum_{l=0}^{\infty} e^{2\alpha l} g^2(l) \leq A < \infty$ . The second sum is bounded for all  $n \geq 0$  since it is the discrete convolution of a strictly stable linear sampled-data system with a bounded input. (Note that  $z(n)$  is bounded for principal cases). Thus, the right-hand side of inequality (12) is bounded for all  $n \geq 0$ . Therefore,

$$|\sigma(n)| \leq B < \infty \quad \forall n \geq 0$$

which implies that the output  $c(n)$  is bounded. This completes the proof of Theorem 1.

Proof of Lemma 1. Because of the restrictions imposed on  $f_1(n)$  and  $f_3(n)$  the Liapunov - Parseval Theorem<sup>3</sup> may be applied.

$$\sum_{n=0}^{\infty} f_1(n) f_3(n) = \frac{1}{2\pi} \int_{-\pi}^{\pi} \overline{F_1^*(e^{j\bar{\omega}})} F_3^*(e^{j\bar{\omega}}) d\bar{\omega} \quad (13)$$

Substituting for  $F_1^*(e^{j\bar{\omega}})$  and noting that the r. h. s. must be real, we obtain

$$\sum_{n=0}^{\infty} f_1(n) f_3(n) = \frac{1}{2\pi} \int_{-\pi}^{\pi} \{ \text{Re } H^* |F_3^*|^2 + \frac{1}{2} [ \overline{F_2^*} F_3^* + F_2^* \overline{F_3^*} ] \} d\bar{\omega} \quad (14)$$

where the arguments have been dropped for ease of notation. The bar indicates the complex conjugate. Completing the square under the

integral sign, we find that

$$\begin{aligned} \sum_{n=0}^{\infty} f_1(n) f_3(n) &= \frac{1}{2\pi} \int_{-\pi}^{\pi} |\sqrt{\text{ReH}^*} F_3^* + \frac{F_2^*}{2\sqrt{\text{ReH}^*}}|^2 d\bar{\omega} \\ &\quad - \frac{1}{8\pi} \int_{-\pi}^{\pi} \frac{|F_2^*|^2}{\text{ReH}^*} d\bar{\omega} \end{aligned} \quad (15)$$

Hence,

$$- \sum_{n=0}^{\infty} f_1(n) f_3(n) \leq \frac{1}{8\pi\beta} \int_{-\pi}^{\pi} |F_2^*(e^{j\bar{\omega}})|^2 d\bar{\omega} \quad (16)$$

or applying again the Liapunov-Parseval Theorem,

$$- \sum_{n=0}^{\infty} f_1(n) f_3(n) \leq \frac{1}{4\beta} \sum_{n=0}^{\infty} [f_2(n)]^2 \quad (17)$$

which completes the proof of Lemma 1.

Proof of Main Lemma. From Eq. (9), one obtains

$$\nabla\sigma(n) = \nabla r(n) - \nabla z(n) - \sum_{j=0}^n \nabla g(n-j) u(j) \quad (18)$$

The functions  $r(n)$ ,  $z(n)$ ,  $\nabla r(n)$ ,  $\nabla z(n)$  and  $u(n)$  will be truncated at  $n=N$  and then denoted by  $r_N(n)$ ,  $z_N(n)$ ,  $(\nabla r)_N(n)$ ,  $(\nabla z)_N(n)$  and  $u_N(n)$ .



By truncation we mean that the functions are identically zero for  $n > N$ .

Then define  $\sigma_N(n)$  and  $(\nabla\sigma)_N(n)$  by the following equations.

$$\sigma_N(n) = r_N(n) - z_N(n) - \sum_{j=0}^n g(n-j) u_N(j) \quad (19)$$

$$(\nabla\sigma)_N(n) = (\nabla r)_N(n) - (\nabla z)_N(n) - \sum_{j=0}^n \nabla g(n-j) u_N(j) \quad (20)$$

Clearly,  $\sigma_N(n) = \sigma(n)$  for  $0 \leq n \leq N$  and  $(\nabla\sigma)_N(n) = \nabla\sigma(n)$  for  $0 \leq n \leq N$ . Note that  $\sigma_N(n)$  and  $(\nabla\sigma)_N(n)$  are not identically zero for  $n > N$  but satisfy the following inequalities

$$|\sigma_N(n)| \leq K_3 e^{-K_2 n}, \quad \forall n > N$$

and

$$|(\nabla\sigma)_N(n)| \leq K_4 e^{-K_2 n}, \quad \forall n > N$$

where  $K_3, K_4$  are positive constants and  $K_2$  was defined in  $|g(n)| \leq K_1 e^{-K_2 n}$ .

Equations (19) and (20) yield

$$\begin{aligned} -\sigma_N(n) - q(\nabla\sigma)_N(n) &= -[r_N(n) - z_N(n) + q((\nabla r)_N(n) - (\nabla z)_N(n))] \\ &+ \sum_{j=0}^n [g(n-j) + q \nabla g(n-j)] u_N(j) \end{aligned} \quad (21)$$

Adding  $\left(\frac{1}{k} - \gamma\right)u_N(n)$  on both sides and multiplying by  $e^{\alpha n}$ ,  $0 < \alpha < K_2$ , one obtains

$$\begin{aligned}
& e^{\alpha n} \left\{ -\sigma_N(n) - q(\nabla\sigma)_N(n) + \left(\frac{1}{k} - \gamma\right) u_N(n) \right\} \\
& = -e^{\alpha n} \left\{ r_N(n) - z_N(n) + q((\nabla r)_N(n) - (\nabla z)_N(n)) \right\} \\
& \quad + \sum_{j=0}^n \left\{ e^{\alpha(n-j)} [g(n-j) + q \nabla g(n-j)] e^{\alpha j} u_N(j) \right\} \\
& \quad + \left(\frac{1}{k} - \gamma\right) e^{\alpha n} u_N(n)
\end{aligned} \tag{22}$$

Identify

$$\begin{aligned}
f_1(n) & = e^{\alpha n} \left\{ -\sigma_N(n) - q(\nabla\sigma)_N(n) + \left(\frac{1}{k} - \gamma\right) u_N(n) \right\} \\
f_2(n) & = -e^{\alpha n} \left\{ r_N(n) - z_N(n) + q((\nabla r)_N(n) - (\nabla z)_N(n)) \right\}
\end{aligned}$$

Then (22) is rewritten as

$$\begin{aligned}
f_1(n) & = f_2(n) + \sum_{j=0}^n \left\{ e^{\alpha(n-j)} [g(n-j) + q \nabla g(n-j)] e^{\alpha j} u_N(j) \right\} \\
& \quad + \left(\frac{1}{k} - \gamma\right) e^{\alpha n} u_N(n)
\end{aligned} \tag{23}$$

Because of the truncation at  $N$  one can take the  $z$ -transform of (23) and be assured that all the transforms are analytic on and outside of the unit circle.<sup>11,12</sup>

$$F_1^*(z) = F_2^*(z) + \left\{ \left[ 1 + q \left( \frac{e^{-\alpha T} z - 1}{e^{-\alpha T} z} \right) \right] G^*(e^{-\alpha T} z) + \frac{1}{k} - \gamma \right\} U_N^*(e^{-\alpha T} z) \quad (24)$$

$$\text{If } \text{Re} \left\{ \left[ 1 + q \left( \frac{e^{-\alpha T} z - 1}{e^{-\alpha T} z} \right) \right] G^*(e^{-\alpha T} z) \right\} + \frac{1}{k} \geq \delta > 0, \quad \forall |z| = 1 \quad (P')$$

and if  $0 < \gamma < \delta$ , then Eq. (24) satisfies the conditions of Lemma 1 with  $\beta = \delta - \gamma$ . It is proved in Appendix I that for sufficiently small  $\alpha > 0$ , satisfaction of (P) implies (P'). Then

$$- \sum_{n=0}^{\infty} f_1(n) u_N(n) e^{\alpha n} \leq \frac{1}{4(\delta - \gamma)} \sum_{n=0}^{\infty} [f_2(n)]^2 \quad (25)$$

Substituting for  $f_1(n)$  and  $f_2(n)$  into (25) and using the fact that certain functions were truncated, we obtain

$$\begin{aligned} & \sum_{n=0}^N e^{2\alpha n} \left( \sigma(n) - \frac{u(n)}{k} \right) u(n) + q \sum_{n=0}^N e^{2\alpha n} u(n) \nabla \sigma(n) + \\ & + \gamma \sum_{n=0}^N e^{2\alpha n} u^2(n) \leq \frac{1}{4(\delta - \gamma)} \sum_{n=0}^N e^{2\alpha n} [r(n) - z(n) + q(\nabla r(n) - \nabla z(n))]^2 \end{aligned} \quad (26)$$

The right hand side of the inequality will be denoted by  $C(N)$ . It is shown in Appendix II that

$$q \sum_{n=0}^N e^{2\alpha n} u(n) \nabla \sigma(n) \geq -\frac{1}{2} q k (e^{2\alpha} - 1) \sum_{n=0}^N e^{2\alpha n} \sigma^2(n) \quad (27)$$

Remember that  $u(n) = \varphi(\sigma(n))$  and note that

$$\left( \sigma - \frac{\varphi(\sigma)}{k} \right) \varphi(\sigma) \geq \frac{\epsilon^2}{k} \sigma^2 \quad (28)$$

since it may be assumed that  $\varphi(\sigma)$  lies in the reduced sector  $[\epsilon, k - \epsilon]$ ,  $\epsilon > 0$  arbitrarily small. Substituting (27) and (28) into (26), we find that inequality (26) is strengthened.

$$\sum_{n=0}^N e^{2\alpha n} \left[ \frac{\epsilon^2}{k} - \frac{1}{2} q k (e^{2\alpha} - 1) \right] \sigma^2(n) + \gamma \sum_{n=0}^N e^{2\alpha n} u^2(n) \leq C(N) \quad (29)$$

Denote  $S_1 = \sum_{n=0}^N e^{2\alpha n} \left[ \frac{\epsilon^2}{k} - \frac{1}{2} q k (e^{2\alpha} - 1) \right] \sigma^2(n)$ .

If for  $\alpha > 0$ ,  $\frac{\epsilon^2}{k} - \frac{1}{2} q k (e^{2\alpha} - 1) \geq 0$ , then  $S_1 \geq 0$  and may be deleted from the left hand side of inequality (29). For any  $\epsilon > 0$ ,  $q < \infty$ ,  $k < \infty$  one can always find an  $\alpha > 0$ , sufficiently small, such that

$$0 < (e^{2\alpha} - 1) \leq \frac{2\epsilon^2}{qk^2}.$$

Setting  $\gamma = \frac{\delta}{2}$ , since  $\gamma$  is arbitrary as long as  $0 < \gamma < \delta$ , inequality (29) becomes

$$\left( \sum_{n=0}^N e^{2\alpha n} u^2(n) \right)^{1/2} \leq \left( \frac{1}{\delta^2} \sum_{n=0}^N e^{2\alpha n} [r(n) - z(n) + q(\nabla r(n) - \nabla z(n))]^2 \right)^{1/2} \quad \forall N \geq 0 \quad (30)$$

which completes the proof of the Main Lemma.

#### IV. Extensions

Note 1. The case where  $\varphi(\sigma)$  satisfies the inequality  $a \leq \frac{\varphi(\sigma)}{\sigma} \leq b$  can be treated by making the change of variables  $\varphi(\sigma) = \hat{\varphi}(\sigma) + a\sigma$ . Then  $\hat{\varphi}(\sigma)$  is contained in the sector  $[0, b-a]$  and Theorem 1 may be applied. For principal cases of  $G^*(z)$  the parameter  $a$  may also assume negative values. If in (P),  $q = 0$ , this test reduces to the circle criterion which is familiar as a stability test for autonomous systems.<sup>2</sup>

Note 2. Using the proof of Theorem 1 it can be easily shown that with  $q = 0$  Theorem 1 proves b. i. b. o. stability when  $N$  in the system  $S$  is a time-varying nonlinearity described by  $u(t) = \varphi[\sigma(t), t]$ . The function  $\varphi(\sigma, t)$  satisfies

$$0 \leq \frac{\varphi(\sigma, t)}{\sigma} \leq k < \infty, \quad \forall \sigma \neq 0, \quad \forall t \geq 0 \quad (31)$$

and

$$\varphi(0, t) = 0, \quad \forall t \geq 0 \quad (32)$$

Note that there are no further restrictions imposed on  $\frac{\partial \varphi}{\partial \sigma}$  or  $\frac{\partial \varphi}{\partial t}$ . This result seems important enough to be stated as a separate theorem.

Theorem 2. Let the system S satisfy the previously stated assumptions on the linear plant G(s) and let the nonlinear element N satisfy conditions (31) and (32). For the system S to be absolutely b. i. b. o. stable in the sector [0, k] for the principal case and in the sector [ $\epsilon$ , k] for the particular cases ( $\epsilon > 0$  arbitrarily small), it is sufficient that for all  $|z| = 1$  the following inequality be satisfied

$$\operatorname{Re} G^*(z) + \frac{1}{k} \geq \delta > 0$$

In addition, for particular cases, the conditions for stability-in-the-limit must be satisfied.

Note 3. The proof given in this paper also establishes absolute stability of the null solution of the autonomous system S. Just set  $r(n) \equiv 0$  in (12) and note that for principal cases  $z(n) \rightarrow 0$  exponentially as  $n \rightarrow \infty$ .

## CONCLUSIONS

The absolute stability in the b. i. b. o. sense of two classes of nonlinear sampled-data systems was investigated. Theorem 1 establishes b. i. b. o. stability for systems with a monotone nonlinear gain contained in a sector, Theorem 2 establishes b. i. b. o. stability for systems with a time-varying nonlinear gain contained in a sector. Theorem 2 is more general, but the stability criterion imposes a stronger condition on the linear plant than the condition of Theorem 1. No examples of the stability theorems were given since the developed stability criteria are identical to the ones for the same class of autonomous systems and several examples already exist in the literature.<sup>1, 2, 3, 4, 7</sup>

## APPENDIX I

### Proof That Satisfaction of Inequality (P) Implies (P').

In the expression of (P') replace  $\delta$  by  $\delta_\alpha$ . It will be shown that this has no consequences and that if there exists a  $\delta > 0$  satisfying (P), then there also exists a  $\delta_\alpha$ ,  $0 < \delta_\alpha < \delta$ , satisfying (P') and  $|\delta - \delta_\alpha| \rightarrow 0$  as  $\alpha$  becomes arbitrarily small. Rewrite (P') as

$$\operatorname{Re} \left\{ \left[ 1 + q \left( \frac{e^{-\alpha T} z - 1}{e^{-\alpha T} z} \right) \right] G^*(e^{-\alpha T} z) \right\} + \frac{1}{k} \geq \delta_\alpha > 0, \quad \forall |z| = 1 \quad (P')$$

Given any principal case  $G^*(z)$ , there exists a sufficiently small  $\alpha > 0$  such that  $G^*(z)$  is analytic in the domain  $|z| \geq e^{-\alpha T}$ . It follows that

$$\left| \left( \frac{e^{-\alpha T} z - 1}{e^{-\alpha T} z} \right) G^*(e^{-\alpha T} z) - \left( \frac{z-1}{z} \right) G^*(z) \right| \quad \text{and} \quad |G^*(e^{-\alpha T} z) - G^*(z)|$$

approach zero uniformly  $\forall |z| = 1$  as  $\alpha > 0$  becomes arbitrarily small.

Then, there exists  $\delta_\alpha$  satisfying (P') such that  $0 < \delta_\alpha < \delta$  and

$$|\delta - \delta_\alpha| \rightarrow 0.$$

## APPENDIX II

It is shown that the following inequality holds.

$$q \sum_{n=0}^N e^{2\alpha n} u(n) \nabla \sigma(n) \geq -\frac{1}{2} q k (e^{2\alpha} - 1) \sum_{n=0}^N e^{2\alpha n} \sigma^2(n) \quad (33)$$



Proof. First note that because  $\varphi(\sigma)$  is a monotone nonlinearity,

$$u(n) \nabla \sigma(n) = \varphi(\sigma(n)) \nabla \sigma(n) \geq \int_{\sigma(n-1)}^{\sigma(n)} \varphi(\sigma) d\sigma$$

Therefore,

$$q \sum_{n=0}^N e^{2\alpha n} u(n) \nabla \sigma(n) \geq q \sum_{n=0}^N e^{2\alpha n} \int_{\sigma(n-1)}^{\sigma(n)} \varphi(\sigma) d\sigma \quad (34)$$

Denote

$$\nabla v(n) = \int_{\sigma(n-1)}^{\sigma(n)} \varphi(\sigma) d\sigma \quad (35)$$

Then

$$v(n) = \sum_{j=0}^n \int_{\sigma(j-1)}^{\sigma(j)} \varphi(\sigma) d\sigma = \int_0^{\sigma(n)} \varphi(\sigma) d\sigma \quad (36)$$

Using (35) and (36), the right hand side of (34) is summed by parts.

Then (34) becomes

$$q \sum_{n=0}^N e^{2\alpha n} u(n) \nabla \sigma(n) \geq q e^{2\alpha N} \int_0^{\sigma(N)} \varphi(\sigma) d\sigma - q(1 - e^{-2\alpha}) \sum_{n=1}^N e^{2\alpha n} \int_0^{\sigma(n-1)} \varphi(\sigma) d\sigma$$

which yields, because of (1) and (2),

$$q \sum_{n=0}^N e^{2\alpha n} u(n) \nabla \sigma(n) \geq -\frac{1}{2} q k (1 - e^{-2\alpha}) \sum_{n=1}^N e^{2\alpha n} \sigma^2(n-1)$$

$$q \sum_{n=0}^N e^{2\alpha n} u(n) \nabla(n) \geq -\frac{1}{2} q k (e^{2\alpha} - 1) \sum_{n=0}^N e^{2\alpha n} \sigma^2(n)$$

which was to be shown.

## REFERENCES

1. Y. Z. Tsypkin, "On the Stability in the Large of Nonlinear Sampled-Data Systems," Dokl. Akad. Nauk SSSR, Vol. 145, pp. 52-55, July 1962.
2. Y. Z. Tsypkin, "Frequency Criteria for the Absolute Stability of Nonlinear Sampled-Data Systems," Automatika i Telemekhanika, Vol. 25, No. 3, pp. 281-290, March 1964.
3. E. I. Jury and B. W. Lee, "On the Stability of a Certain Class of Nonlinear Sampled-Data Systems," IEEE Trans., PGAC, pp. 51-61, January 1964.
4. E. I. Jury and B. W. Lee, "A Note on the Absolute Stability of Nonlinear Sampled-Data Systems," IEEE Trans., PGAC, pp. 551-554, October 1964.
5. E. I. Jury and B. W. Lee, "The Absolute Stability of Systems with Many Nonlinearities," Automatika i Telemekhanika, Vol. 26, No. 6, pp. 945-965, June 1965.
6. J. B. Pearson and J. E. Gibson, "On the Stability of a Class of Saturating Sampled-Data Systems," IEEE Trans. on Applic. and Industry, Vol. 83, 1964, pp. 81-86.
7. G. P. Szegö and J. B. Pearson, "On the Absolute Stability of Sampled-Data Systems: the 'Indirect Control' Case," IEEE Trans., PGAC, pp. 160-163, April 1964.

8. G. P. Szegö, "On the Absolute Stability of Sampled-Data Control Systems," Proc. Natl. Acad. of Sci. U. S. , Vol. 49, No. 9, pp. 558-560, 1963.
9. I. W. Sandberg, "Some Stability Results Related to those of V. M. Popov," B.S. T.J. , Vol. XLIV, pp. 2133-2147, November 1965.
10. A. R. Bergen, R. P. Iwens and A. J. Rault, "On Bounded-Input - Bounded-Output Stability of Nonlinear Feedback Systems," ERL Technical Memorandum, M-155, University of California, April 1966, Berkeley, California.  
  
(Also submitted for publication to IEEE Trans. , PGAC.)
11. E. I. Jury, "Sampled-Data Control Systems," John Wiley and Sons, New York, 1958.
12. E. I. Jury, "Theory and Application of the Z-Transform Method," John Wiley and Sons, New York, 1964.
13. M. A. Aizerman and F. R. Gantmacher, "Absolute Stability of Regulator Systems," Holden Day, Inc. , San Francisco, 1964.