

Copyright © 1966, by the author(s).
All rights reserved.

Permission to make digital or hard copies of all or part of this work for personal or classroom use is granted without fee provided that copies are not made or distributed for profit or commercial advantage and that copies bear this notice and the full citation on the first page. To copy otherwise, to republish, to post on servers or to redistribute to lists, requires prior specific permission.

ON THE NEURON MODELING

by

E. I. Jury and J. G. Blanchard

Memorandum No. ERL-M172

1 August 1966

ELECTRONICS RESEARCH LABORATORY

College of Engineering
University of California, Berkeley
94720

Manuscript submitted: 23 May 1966

The research reported herein was supported wholly by the Air Force
Office of Scientific Research under Grant AF-AFOSR-282-64/66.

ABSTRACT

A simplified model of a neural element which can be of interest in the study of sensory receptors and the transmission of information to the axons is obtained in this work. This model exhibits the time-varying adaptive characteristics of the neuron receptor. These characteristics are supported by physiological experiments. It is furthermore shown that the model describes satisfactorily the main electrical properties encountered in the electrical behavior of a neural membrane and that digital simulation can be easily achieved.

I. INTRODUCTION

Several attempts have been made in the past to simulate by electrical networks the behavior of neural elements. Physiologists [1] have tried to match their experimental results with partly empirical formulas describing the variations of the main chemical or electrical factors taken into consideration. Engineers in the field of bioengineering have directed their efforts toward developing models reproducing qualitatively the main electrical properties of the neurons [2-4].

A brief survey of the literature shows that the connection between the work of physiologists and bioengineers is not always as strong as would be desirable. For some reasons, due mainly to the complexity of the phenomena to be studied, the different models presented by engineers appear to lack a certain unity which would have been preserved if more attention had been devoted to the assumptions, approximations, and limitations involved. Furthermore, as the models become more and more sophisticated, the risk of making speculative assumptions increases unless the physiological aspects of the problem are constantly kept in mind. Finally, it appears that the models in question do not display enough degrees of freedom to take into account most of the parameters influencing the neural behavior.

It is our opinion that the problem of neuron modeling ought to be further studied if the work of bioengineers is to contribute more in

this particular domain of neurophysiology. Further research could be oriented in two different directions:

1. Accurate models could be developed based on quantitative and qualitative experimental data on chemical and electrical behavior of the precise neural element to be studied. Owing to the nonlinear and time-varying character of the phenomena involved, it is likely that any model of this sort will necessarily be complex and defy any serious analysis with the mathematical tools now available. However, a computer study is always possible. Any such attempt should require the combined efforts of physiologists and engineers. It would be particularly helpful if further investigation were made of the neural properties as a function of different parameters, such as temperature or external chemical concentration.

2. Simplified models could be developed, in which more initiative could be left to the bioengineer, in order to investigate very complex problems such as those arising in the behavior of groups of neurons or synapses. Any approach to those problems should require definitions and methods not always available to the physiologist. Optimal models could then be defined with respect to certain performance criteria corresponding to the particular behavioral function (or functions) to be studied. By such a study, one may acquire knowledge related to the phenomena of adaptive behavior data handling and the process of

transforming information. Hence, one can apply such knowledge to man-made machines. In the following discussions, we will present a model for the sensory receptor and indicate the mathematical description of this model. Furthermore, the model properties are compared with the biological properties of the neuron and close agreement is obtained.

II. A SIMPLIFIED MODEL BASED ON THE PROPERTIES OF FUNCTIONAL PULSE-FREQUENCY MODULATION WITH TIME-VARYING THRESHOLD

The physiological behavior of the neural sensory receptor is briefly discussed (for a more detailed study see Selkurt [5]) in this paper.

As shown in Fig. 1, the original stimulus (could be pressure) causes a deformation of the dendritic branches of the receptor. A long-lasting depolarization of the "resting potential", known as "generator potential", follows. The generator potential acts as a persistent cathodal stimulus generating current that cause the initial segment of the axon to respond repetitively to the depolarization. A block diagram of Fig. 1 is shown in Fig. 1a. This system is composed of two parts:

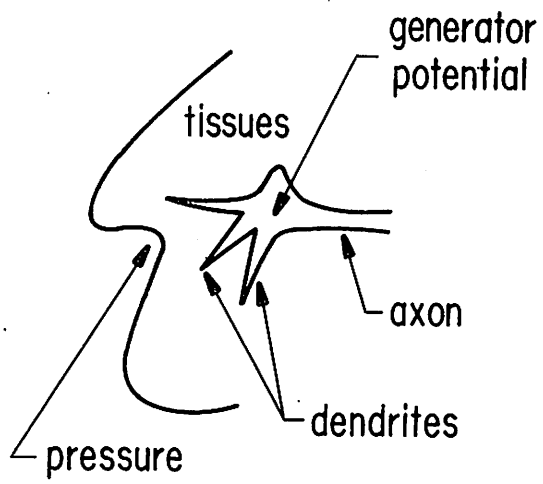

Fig. 1. Sensory receptor.

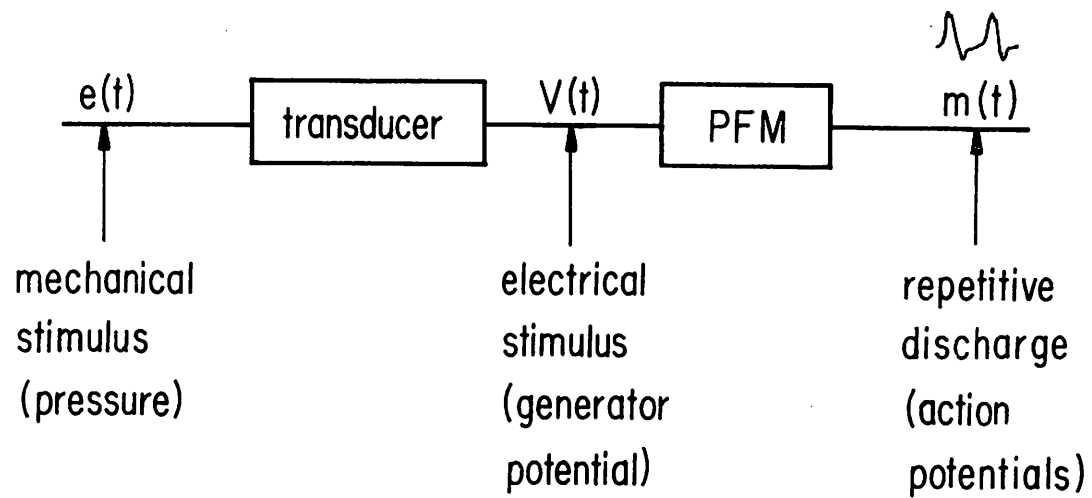

Fig. 1a. Equivalent system of the sensory receptor.

1. A transducer which connects the original stimulus $e(t)$ into the electrical stimulus $V(t)$ (generator potential), and

2. A modulator which converts the information provided by the generator potential $V(t)$ into a sequence of pulses $m(t)$ (action potential) called the repetitive discharge. In the following, both the transducer and modulator are discussed in detail.

Transducer

The transducer is assumed to be a linear time-invariant system for small values of the input $e(t)$. For large values of $e(t)$, saturation effect exists and thus we have:

$$V(t) = \int_0^t h(t - u) g[e(u)] du \quad (1)$$

where $g[e(u)]$ is shown in Fig. 2. As a first approximation $h(t)$ may be considered equal to e^{-at} with $a \geq 0$.

Modulator

The modulator part represents the most important factor in the system study of the neuron receptor. It generates a sequence of pulses which convey information about the original stimulus to centers of motion or higher centers, as the brain, where it is processed. Certain

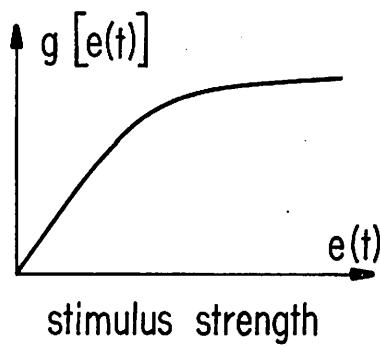

Fig. 2. Saturation curve of the electrical structures.

forms of the modulator have been proposed [4, 6], but the present extended form fits more closely with the electrical properties.

The modulator, called "Pulse Frequency Modulator" (PFM) in this paper, is defined by the use of the following equations. These equations represent certain symbols which are indicated in Appendix I.

$$I_v(t, t'_k) \triangleq \int_{t'_k}^t \exp[-c(v - t'_k)] V(v) dv, \quad t \geq t'_k \quad (2)$$

$$T_k(t) \triangleq \frac{T_0 \exp[f_k(t - t'_k)]}{1 - \exp[-q(t - t'_k - t_r)]} \quad (3)$$

$$p_h(t) \triangleq h p(t - t_k) \quad (4)$$

In the above equations, the symbols used are explained as follows. The parameters h , q , T_0 are positive constants. The symbols t_r and c are positive or equal to zero. The time t_k is the instant at which the kth pulse (action potential) is emitted (k is a positive integer to count the action potentials). In order to account for the time of application of the stimulus $V(t)$, chosen as the origin of time, the value $k = 0$ will also be considered. Hence, $t_0 = 0$.

The potential $V(t)$ is the generator potential (assumed positive).

The function $p(t)$ is a continuous function of time, equal to zero outside a certain interval $(0, d)$ where d is positive constant (see Fig. 3).

Furthermore, we also have

$$\left. \begin{aligned} t'_k &= t_k + d, \\ t'_0 &= t_0 = 0 \end{aligned} \right\} \text{ if } k > 0. \quad (5)$$

The function f_k is defined as :

$$f_k(t - t'_k) = bk \exp[-a(t - t'_k)] \quad (6)$$

where b and a are positive constants or equal to zero.

From the above equations we can determine the input-output relationship of the modulator.

Assume that an action potential has been emitted at time t_k . The value of t_{k+1} (the time of the next action potential) is the smallest root, greater than t'_k , of the following equation. (See Appendix I)

$$I_v(t, t'_k) - T_k(t) = 0 \quad (7)$$

or alternatively (from Eqs. (2) and (3)) of the following equivalent relationship

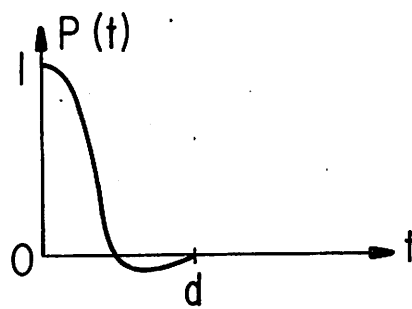

Fig. 3. Normalized action potential.

$$\int_{t'_k}^t \exp[-c(v - t'_k)] V(v) dv = \frac{T_0 e^{b_k \exp[-a(t-t'_k)]}}{1 - \exp[-q(t - t'_k - t_r)]} \quad (8)$$

The output of the modulator, Fig. 4, is equal to $I_v(t, t'_k)$ in the interval (t'_k, t_{k+1}) and $p_h(t - t_{k+1})$, for $t_{k+1} \leq t \leq t'_{k+1}$. Hence,

$$m(t) = \sum_k \left[I_v(t, t'_k) \left\{ l(t - t'_k) - l(t - t_{k+1}) \right\} + p_h(t - t_{k+1}) \right] \quad (9)$$

($k \geq 0$)

where $l(t)$ is the unit step.

The determination of the modulator output for a constant input is shown in Fig. 4.

It is of interest to note that if we set $c = 0$, $t_r = 0$, $d = \epsilon$, $b = 0$, $q = \infty$ in Eq. (8) and let, furthermore, $h = \mu/\epsilon$, the modulator becomes identical to IPFM (Integral Pulse Frequency Modulator). Such a modulator has been proposed in an earlier work [4]. Furthermore, if we let $c \neq 0$ with the above values, the modulator becomes equivalent to FPFM (Functional Pulse Frequency Modulator) [8] corresponding to the decision function $\int_0^t e^{-cv} V(v) dv$. The study of such a modulator in an engineering application is of importance [8] (also see Appendix I).

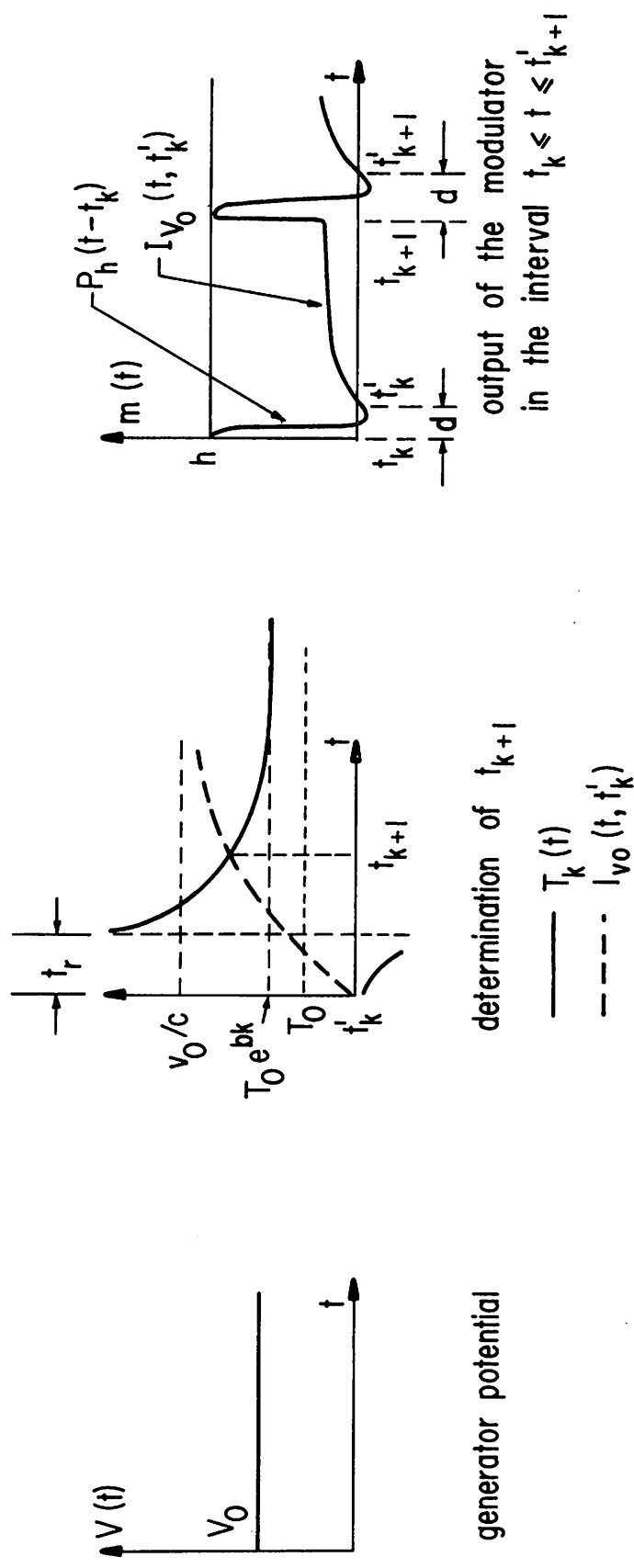

Fig. 4. Graphical determination of the sequence $\{t_k\}$ and modulator output representation for a constant input.

III. RELATIONSHIP BETWEEN THE MATHEMATICAL PARAMETERS AND THE PHYSIOLOGICAL CHARACTERISTICS OF THE SENSORY RECEPTOR

In this part an explanation of the physiological phenomena related to Eqs. (2) - (4) will be presented.

The function $I_v(t, t'_k)$ describes the variation of a "subthreshold potential," as a function of the stimulus $V(t)$ and t . The constant "c" refers to the delay separating the start of a "stimulus above threshold" and the time of emission of an action potential. The function $T_k(t)$ refers to the time-varying threshold of the membrane. The term " T_0 " can be described as the value of the membrane threshold when no action potential has been elicited. One feature of this function is that it reduces to " T_0 " when an action potential has been elicited at $t = t'_k$ and when in the interval (t'_k, ∞) , the stimulus remains subthreshold, i. e., $T_k(t) \rightarrow T_0$ when $t \rightarrow \infty$. This is seen from Eq. (3).

The rate of adaptation of the receptor is represented by "b", which is generally a small value. The term $\exp[-a(t - t'_k)]$, the quantity "q", and the function $1/1 - \exp[-q(t - t'_k - t_r)]$, are related to the variation of excitability after the period of absolute refractoriness, following the emission of an action potential. They refer to the "relative refractoriness". It is assumed that "q" is much larger than "a". This is justified because when an action potential has been elicited

at $t = t'_k$, the excitability (the inverse of the threshold $T_k(t)$), increases rapidly from its null value at $t = t'_k$ to a value close to $1/T_0 e^{bk}$ (as "q" is large). Afterwards it returns slowly ("a" is small) to the value $1/T_0$.

The function $p_h(t)$ describes the form of the action potential. The coefficient "h" is used to adjust its magnitude. It should be noted that the origin of the potential axis has been taken as $(-E_r)$ (where E_r is the resting value of the membrane potential). Finally, " $t_r + d$ " represents the period of the "absolute refractoriness" (explained below).

The function $V(t)$, the input to the modulator, is assumed to be positive because we are considering the case of a depolarizing generator potential. Finally, the parameters (c , b , q , h , t_r , a and T_0) as well as the function $p_0(t)$ are chosen from experimental data available in the literature [9]. Appendix II illustrates a range of possible numerical values.

IV. AGREEMENT BETWEEN THE MODULATOR PROPERTIES AND THE ELECTRICAL PROPERTIES OF THE SENSORY RECEPTOR

In this part, the electrical properties of the neural element considered are enumerated first, then it is shown that the modulator characteristics represent all these experimentally measured or observed properties:

1. Nondependence of the action potential on the stimulus $V(t)$ [5],
2. Strength-duration curve (for constant stimulus) [5],
3. Gradient threshold curve (ramp input as a stimulus) [5],
4. Absolute and relative refractoriness (for constant stimulus) [5], and
5. Adaptation (for constant stimulus) [5].

Property 1.

From Eq. (4), the term $p_h(t - t_{k+1})$ which represents the action potential emitted at time $t = t_{k+1}$ does not depend on $V(t)$, except for its emission time.

Property 2.

If we use a constant stimulus $V(t) = V_0$ in Eqs. (2) and (3), we obtain the following equation for determining t_1 (the emission time of the first action potential):

$$\int_0^{t_1} e^{-cv} V_0 dv = T_0 . \quad (10)$$

or

$$\frac{v_0}{c} \left(1 - e^{-ct_1} \right) = T_0 . \quad (11)$$

Therefore,

$$t_1 = -\frac{1}{c} \log \left(1 - \frac{T_0 c}{V_0} \right) . \quad (12)$$

It is immediately noticed from Eq. (12) that no excitation (elicitation of an action potential) exists if $V_0 \leq cT_0$. The value " cT_0 " is called the Rheobase. The strength-duration curve follows directly from Eq. (12). This is shown in Fig. 5. It should be noted that Eq. (12) will also hold for any interval (t_k, t) .

Property 3.

The gradient threshold curve corresponds to the case of a ramp input, i. e., $V(t) \leq st$, where s is a positive constant. From Eq. (2), we obtain

$$\int_0^t sv e^{-cv} dv = I_v(t, 0) \text{ for } t \leq t_1 , \quad (13)$$

or

$$I_v(t, 0) = -\frac{s}{c} t e^{-ct} + \frac{s}{c} \left(1 - e^{-ct} \right) . \quad (14)$$

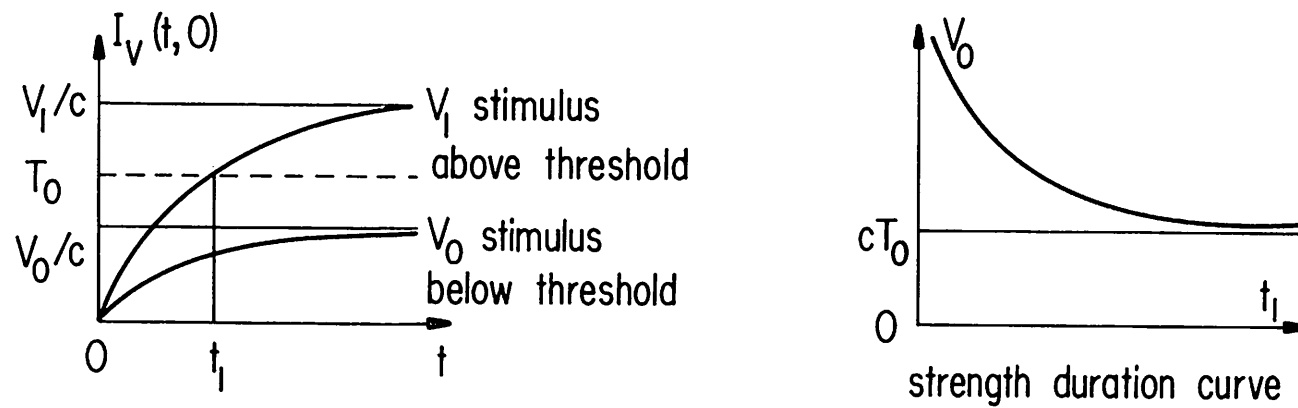

Fig. 5. Determination of strength duration curve.

The function $I_v(t, 0)$ is monotonically increasing as seen from Eq. (14) and its maximum is s/c^2 . Therefore, no excitation occurs for $s < c^2 T_0$. This value of $c^2 T_0$ corresponds to the gradient threshold. From Eq. (14) (by setting $I_v(t, 0) = T_0$) we deduce the gradient threshold equation as follows:

$$\frac{s}{c^2} = \frac{T_0}{1 - e^{-ct_1} - ct_1 e^{-ct_1}} \quad (15)$$

The above equation is plotted in Fig. 6, which is known as the gradient threshold curve.

Property 4.

We assume as before $V(t) = V_0$ (= constant) and furthermore let t_k be the emission time of an action potential ($k \geq 1$). From Eqs. (2) and (3), we obtain the following relationship which enables us to obtain t_{k+1} the emission time of the next action potential.

$$V_0 \left[1 - \exp[-c(t - t_k')] \right] = \frac{cT_0 \exp \left[bk e^{-a(t-t_k')} \right]}{1 - \exp[-q(t - t_k' - t_r)]}, \quad t > t_k' \quad (16)$$

The left side of Eq. (16) is always positive for $t > t_k'$, whereas the right side is only positive for $t > t_k' + t_r$ (see also Fig. 7). Hence

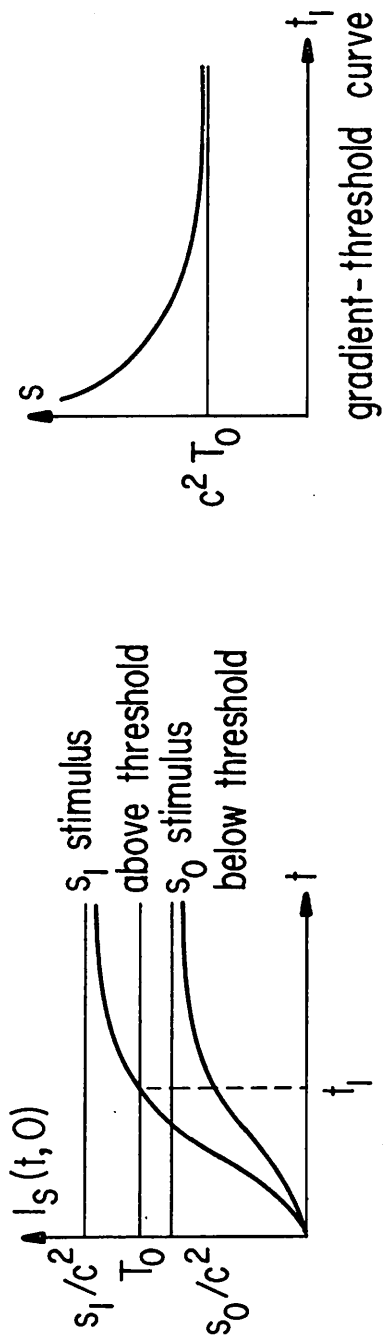

Fig. 6. Determination of gradient-threshold curve.

Eq. (16) cannot have a root in the interval $(t_k, t'_k + t_r)$. This indicates that no action potential may be elicited in the interval $d + t_r$ following the emission time t_k of the preceding action potential. Consequently, $t'_r = t_r + d$ corresponds to the "Absolute Refractoriness Period".

In some cases the refractory period may be longer than the duration of the action potential, therefore the constant t_r is introduced.

The phenomena of "Relative Refractoriness" is also exhibited by this modulator. This is observed from the variation of $T_k(t)$ for $t > t'_k + t_r$. This property indicates that the excitability (the eventual emission of an action potential after t_k) increases with time after the absolute refractory period has elapsed (see Fig. 7).

Property 5.

Assume that $V = V_0$ and consider two values k_1 and k_2 of $k(k_1 < k_2)$ corresponding to two action potentials emitted at t_{k_1} and t_{k_2} . Further, consider the value t_{k_1+1} and t_{k_2+1} the emission times of action potential emitted after t_{k_1} and t_{k_2} . The values of t_{k_1+1} and t_{k_2+2} can be obtained from Eq. (16). These two equalities are presented graphically in Fig. 8. It is observed that when $k_2 > k_1$, it implies $t_{k_2+1} - t_{k_2} > t_{k_1+1} - t_{k_1}$. This indicates that as long as t_{k+1} exists, $t_{k+1} - t_k$ increases with k . This property corresponds to the property of "Adaptation".

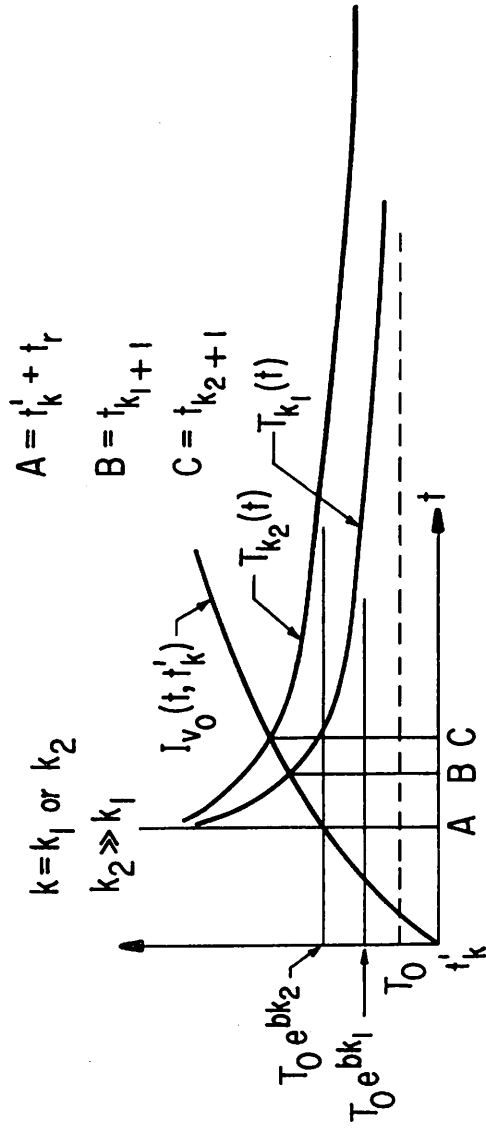

Fig. 8. Adaptation properties of the receptor.

To show the above property analytically, let $t = t'_k + \Delta t$. If $k_1 < k_2$, we have

$$\exp\left[-bk_1 e^{-a(\Delta t)}\right] < \exp\left[-bk_2 e^{-a\Delta t}\right] \text{ for all } \Delta t \geq 0. \quad (17)$$

Therefore from Eqs. (3) and (17),

$$T_{k_1}\left(\Delta t + t'_{k_1}\right) < T_{k_2}\left(\Delta t + t'_{k_2}\right) \text{ for all } \Delta t \geq 0. \quad (18)$$

The curve corresponding to the left side of Eq. (16), will intersect the curve $T_{k_1}\left(\Delta t + t'_{k_1}\right)$ before intersecting the curve $T_{k_2}\left(\Delta t + t'_{k_2}\right)$ (see Fig. 8).

V. CONCLUSION

In this paper it is shown that the model presented exhibits the main properties of the sensory receptors. A sufficient number of parameters are presented in the definition of the modulators, which can be adjusted to fit the particular neural element to simulate. It may be emphasized that some properties of the sensory receptors, such as the gradient threshold and adaptation, are exhibited by our modulator only because of the time-varying nature. In previous models using invariant models [6], these important properties are not exhibited.

Though a simpler model such as IPFM modulator can be used for simulation, such models have no strong ties with the main properties of the neural receptors. It is of interest to note that such a simplified model can be deduced as a special case of the modulator introduced herein. This can be achieved by setting some or all the parameters (c , t_r , d , b , h , q) to zero or infinity as required.

From the model presented in this paper, one should attempt to extend the study to multineuron elements, i. e., neurons connected in cascade or parallel or a combination of both. By performing such a study, we can gain deep insight on information processing in the neurons. This would also aid us in the study of large scale systems. Some research in this direction has been recently introduced but further research in this area is indeed warranted. Finally, the model presented in this work can be simulated on a digital computer and will thus aid in the study of complex neuron connections. Such a study presently defines the analytical tools available; thus, the use of digital computers should be more emphasized in future work.

REFERENCES

1. A. L. Hodgkin and A. F. Huxley, "A quantitative description of membrane currents and its application to conduction and excitation in nerve," J. Physiol., 117, pp. 500-544, March 1952.
2. L. D. Harmon, "Artificial neuron," Science, 129, April 1959.
3. F. F. Hiltz, "Analog computer simulation of a neural element," IRE Trans. on Bio-medical Engineering, January 1962.
4. Jones, et al. "Pulse modulation in physiological systems, phenomenological aspects," IRE Trans. on Bio-medical Engineering, January 1961.
5. E. E. Selkurt, Physiology, Little Brown and Co., Boston, 1962.
6. T. Pavlidis, "A new model for single neural nets and its application in the design of a neural oscillator," Bull. Math. Biophysics, Vol. 27, June 1965.
7. Farrenkopf, et al., "An integral pulse frequency on-off attitude control system," Technical Report, March 1963, Space Technology Laboratories.
8. J. G. Blanchard, "Theory and applications of pulse frequency modulated system," Ph.D. thesis, Department of Electrical Engineering, University of California at Berkeley, January 1966.

9. J. Gray and M. Sata, J. Physiology, 122, p. 610, 1953.
10. I. Tasaki, "Conduction of nerve impulse," Handbook of Physiology - Section I, Neurophysiology, American Physiological Society, 1959.
11. E. A. Lyubinskii and N. V. Poziv, "Modeling information processing by neurons," Automatic and Telemechanics, Vol. 26, No. 10, pp. 1746-1756, Oct. 1965, Moscow, U.S.S.R.
12. T. Pavlidis, "Design of neural nets with intermittent response and certain other relevant studies," Bull. Math. Biophysics, Vol. 28, 1366, pp. 51-74.
13. P. G. Caumon, "A neuron modeling," M.S. project, University of California at Berkeley, June 1965.

APPENDIX I

The Modulator Definitions [8]

A Functional Pulse-Frequency Modulator is defined as a system operating on continuous or piecewise, continuous inputs and converting them into sequences of pulses with the following properties.

The shape of the pulse (magnitude and form) is a priori determined. The pulses are numbered by an index k (k integer ≥ 1). The k th pulse is fully characterized by its emission time t_k , its sign ϵ_k ($\epsilon_k = \pm 1$) and a given function $p(t)$ describing its shape. If $p(t)$ is a function of time, it is assumed to have a bounded support, i. e., there exists a finite interval (α, β) while $\alpha \leq 0$, $\beta \geq 0$ such that $p(t)$ is identically equal to zero for all $t \notin (\alpha, \beta)$. It should be noted that $p(t)$ can also be a generalized function as $\delta(t)$. In many applications when the shape is of no importance $p(t)$ is considered as $\delta(t)$.

To characterize the modulator output we characterize the function $I_x(\theta, \theta')$ and the parameters T and μ which are constrained to be positive or zero.

The input $X(t)$ to the modulator is assumed to be continuous or piecewise continuous for all $t \geq 0$ and equal to zero for all $t < 0$. We further consider two arbitrary finite numbers θ, θ' and denote by $(X(t), \theta, \theta')$ a point in the space. A function X is defined, which assigns to every such point in this space a real number denoted by $I_x(\theta, \theta')$.

The four quantities $(I_x(0, t), p(t), T, \mu)$ fully characterize the input-output relationship of the modulator.

Let $X(t)$ be the input signal to the modulator. The corresponding output of the modulator is:

$$m(t) = \mu \sum_{k \geq 1} \epsilon_k p(t - t_k) \quad (\text{A-1})$$

If we let $t_0 = 0$, then ϵ_k and t_k are determined in a recursive manner as follows:

$$t_k = \min \left\{ t \mid |I_x(t_{k-1}, t)| = T, \quad t > t_{k-1} \right\} \quad (\text{A-2})$$

$$\epsilon_k = \text{sign} \left\{ I_x(t_{k-1}, t_k) \right\} \quad (\text{A-3})$$

Thus if $X(t)$ is given, then the modulator output $m(t)$ is uniquely determined. The above definition of the modulator represents a non-linear and time-varying form.

APPENDIX II

Some Numerical Values For Parameters Used In This Paper

- c (stimulus-excitation delay factor) = $1(\text{ms})^{-1}$, (millisecond)⁻¹
- $t_r + d$ (absolute refractory period) = 1 ms (millisecond)
- q (relative refractoriness factor) = $(2 \text{ ms})^{-1}$
- T_0 (threshold) = 20(ms) (mV), (milliseconds millivolts)
- h (Action Potential value) = 100 mV (millivolt)
- a^{-1} (parameter determining the time required for the threshold to return into its resting value = 100 ms)
- b (adaptation factor) = $\begin{cases} 10^{-3} & \text{for pressure receptors.} \\ 10^{-2} & \text{for touch receptors.} \end{cases}$