

Copyright © 1966, by the author(s).
All rights reserved.

Permission to make digital or hard copies of all or part of this work for personal or classroom use is granted without fee provided that copies are not made or distributed for profit or commercial advantage and that copies bear this notice and the full citation on the first page. To copy otherwise, to republish, to post on servers or to redistribute to lists, requires prior specific permission.

PROPOSED NEW METHOD FOR GENERATING
HIGH-FREQUENCY ELASTIC WAVES

by

R. M. White

Memorandum No. ERL-M196

1 December 1966

ELECTRONICS RESEARCH LABORATORY

College of Engineering
University of California, Berkeley
94720

Manuscript submitted: 17 November 1966

INTRODUCTION

A now conventional method of generating coherent elastic plane waves at gigahertz frequencies in solids involves the application of rf electric fields at one plane surface of a piezoelectric substance. This type of wave generation is convenient since it requires the preparation of only one plane surface on the solid, but the coupling is not particularly efficient. Note that when computing the efficiency of this method of elastic wave production, one must consider the efficiency of the source producing the rf power as well as the efficiency of the transduction process itself.

A new method of generating elastic waves is proposed here which does not directly involve the production of rf electrical power and its subsequent conversion to elastic waves. Thus the overall efficiency obtainable by this method is not limited by the efficiency of available rf power sources. It is not yet known what efficiency is characteristic of the new method, but one can say at least that the calculation of efficiency is quite different from that for the conventional method.

Both the new and the conventional method mentioned above depend on the fact that in the elastic wave equation characterizing the transducing medium, the source term is the spatial derivative of the product eE , where e is a piezoelectric coupling coefficient and E is a component of electric field.

PROPOSED METHOD

It is proposed that elastic waves be generated by placing a piezoelectric solid adjacent to an oscillating semiconductor diode, such

as a Gunn effect diode (Fig. 1). The diode is positioned with its ohmic contact surfaces perpendicular to a polished plane surface of the piezoelectric block. The diode is powered either by a steady or pulsed direct current supply. The diode and the block must be placed quite close to each other; they may be in actual mechanical contact if the block is a sufficiently good electrical insulator.

The transducer action depends upon the well-known existence of regions of high electric field which move through the oscillating semiconductor diode. These high field regions exist because of charge bunching in the diode. The amplitudes of the electric fields inside and outside the diode may be many tens or hundreds of kilovolts per centimeter. Theoretical calculations and external probe measurements show that the regions of high electric field may be well localized; typically in a gallium-arsenide Gunn-effect diode, the region may be a plane about one micron thick, parallel to the ohmic contacts. Thus, near the surface of a piezoelectric block adjacent to the diode there is a moving sound source, because there is a moving region in which eE has a large gradient.

The velocity with which the sound source moves through the diode of Fig. 1 may be much higher than the velocity of sound in the block. For example, in a gallium-arsenide Gunn-effect diode the former velocity, v_0 , is near the saturated electron drift velocity, typically 10^7 cm/sec, while the velocity of sound, v_s , in most solids is near 5×10^5 cm/sec. The situation is thus analogous to the formation of a shock wave by a supersonic projectile, or the production of \hat{C} erenkov radiation by an energetic charged particle moving through an insulator at a velocity greater than the velocity of electromagnetic waves in the medium. We should expect a single moving line source to produce an elastic wave propagating outward at an acute angle to the interface, as shown in Fig. 2. The angle $\theta = \cos^{-1}(v_s/v_0)$.

If a single source moves along the interface, a plane elastic disturbance is produced whose frequency spectrum reflects the wide frequency spectrum of the source itself. If a time-periodic sequence of sources moves along the interface, then the spectra of both the source fields and the output will contain large components at the source repetition frequency.

OPERATING CHARACTERISTICS

Direction of wave propagation: Because the ratio of source velocity to sound velocity determines the angle θ , that angle may be changed by changing the velocity v_0 (or v_s , which is apparently difficult). It is known that in certain Gunn diodes the velocity v_0 is dependent on bias, and changes up to 25% have been observed. Furthermore, if the bias polarity is reversed, the waves will travel to the left in Figs. 1 and 2, rather than to the right. Thus it appears possible to make substantial digital changes in angle by reversing the polarity of the bias, and smaller incremental changes in angle by varying the amplitude of the bias.

Frequency of operation: Semiconductor diodes exhibiting relatively well localized regions of high electric field have been operated at megahertz frequencies and in the 0.5 to 33 gigahertz range; the former have been elastic wave oscillators employing piezoelectric semiconductors, and the latter have been Gunn-effect diodes which depend upon inter-valley scattering for their operation. The former have exhibited domain motion only at sonic velocities, so the use of such diodes in the arrangement of Fig. 1 might be instructive and useful, but would not generally exhibit the same directional radiating characteristics as would the use of Gunn diodes. It should be noted that changes in oscillation frequency can be achieved in some of the Gunn diodes with the use of appropriate external circuitry; thus production of some radiation having a variable frequency and variable direction of propagation appears possible with this method of transduction.

In the interest of maximizing conversion efficiency, it might be desirable to use a diode in the shape of a thin plate whose dimension in the x direction is small compared with its y and z dimensions.

Wave type: Because of the high amplitude electric fields furnished by semiconductor oscillator diodes, one can consider using electrostrictive solids as well as piezoelectric ones as the block of Fig 1. The electrostrictive effect is present in all solids and fluids, and it produces particle displacements which are proportional to the square of the electric field, rather than to the first power of the field as is the case with piezoelectric substances. A compressional bulk wave should be produced by the electrostrictive solid, whereas one expects that in an arbitrarily-oriented piezoelectric solid operated as shown in Fig. 1 both compressional and shear bulk waves would be produced.

APPLICATIONS

It is anticipated that the transducer described might be useful in many cases where elastic waves are presently employed, such as in signal delay lines having fixed or variable delay times, optical deflection and modulation devices, and in physical studies involving high-frequency elastic waves. It may be noted that the diode need not be in mechanical contact with the adjacent solid. Thus there need be no acoustic bonding problem, and no acoustic loading of the solid block by the diode, and no interference with light incident internally on the interface at an angle proper for total internal reflection.

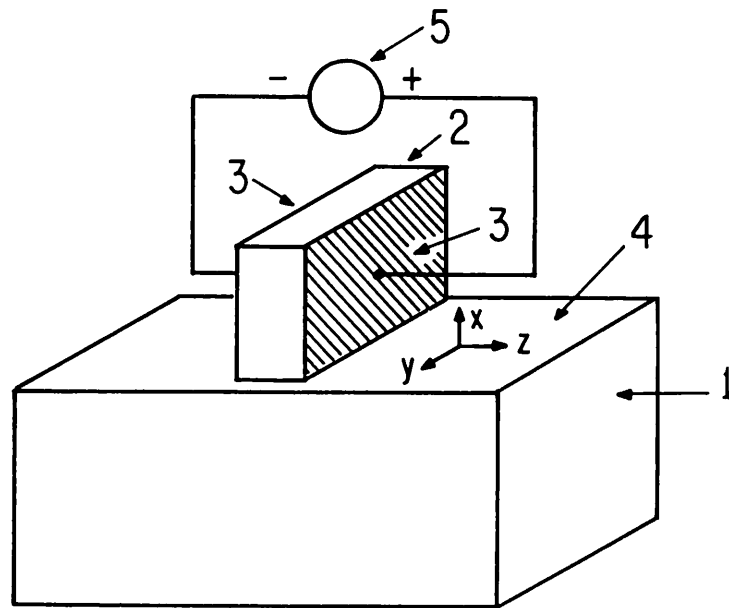

Fig. 1. Sketch of proposed new method for generating elastic waves. 1 - insulating block in which waves are produced. 2 - semiconductor diode. 3 - ohmic contacts. 4 - plane surface on or near which diode is mounted. 5 - steady or pulsed direct current source.

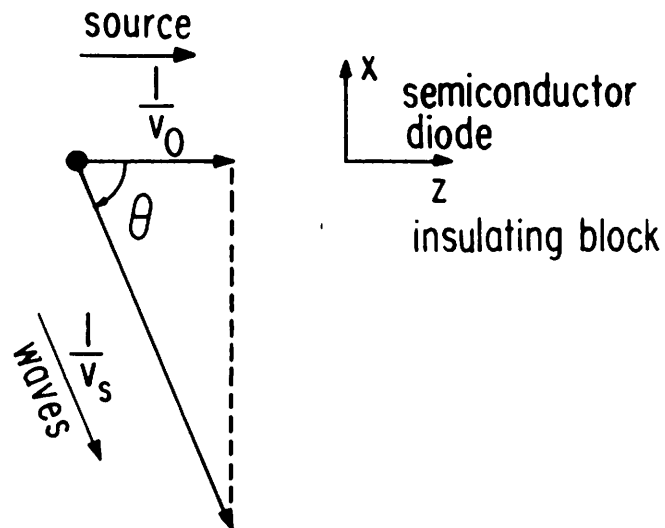

Fig. 2. Cross-section showing xz plane of Fig. 1 giving directions of elastic wave propagation and motion of wave source at interface ($x = 0$). Source velocity is v_0 , sound velocity v_s .