

Copyright © 1975, by the author(s).
All rights reserved.

Permission to make digital or hard copies of all or part of this work for personal or classroom use is granted without fee provided that copies are not made or distributed for profit or commercial advantage and that copies bear this notice and the full citation on the first page. To copy otherwise, to republish, to post on servers or to redistribute to lists, requires prior specific permission.

SOLUTION OF LARGE-SCALE NETWORKS BY TEARING

by

Felix F. Wu

Memorandum No. ERL-M532

7 July 1975

cover

SOLUTION OF LARGE-SCALE NETWORKS BY TEARING

by

Felix F. Wu

Memorandum No. ERL-M532

7 July 1975

ELECTRONICS RESEARCH LABORATORY

College of Engineering
University of California, Berkeley
94720

SOLUTION OF LARGE-SCALE NETWORKS BY TEARING

Felix F. Wu

Department of Electrical Engineering and Computer Sciences
and the Electronics Research Laboratory
University of California, Berkeley, California 94720

Abstract

A generalized method of tearing, or diakoptics, for solving large-scale networks is derived. The idea of diakoptics is viewed as simply the partition of branches and the Kirchhoff laws. A solution algorithm which incorporates the sparse matrix techniques is presented. A generic condition under which the algorithm can be applied is given. The algorithm can be implemented utilizing parallel computation scheme or series computation scheme, if the network can be torn apart. The computational comparison between the diakoptic analysis and the conventional analysis is studied.

Research sponsored by the National Science Foundation under Grant ENG74-06651-A01 and GK-37447.

I. Introduction

Consider a network \mathcal{N} consisting of many subnetworks $\mathcal{N}_1, \mathcal{N}_2, \dots, \mathcal{N}_k$ interconnected together by the branches t_1, t_2, \dots, t_ℓ (Fig. 1). Such networks are common in practice, e.g. large-scale interconnected power systems. We may view the set of branches t_1, \dots, t_ℓ as having the property that their removal tears the network apart into several independent subnetworks. The original suggestion of the method of tearing, or "diakoptics", is to solve the network problem in two steps: (i) subnetwork level: one tears away the branches t_1, t_2, \dots, t_ℓ and solves the subnetworks $\mathcal{N}_1, \mathcal{N}_2, \dots, \mathcal{N}_k$ independently, (ii) interconnection level: one somehow combines these results with the branch variables associated with t_1, t_2, \dots, t_ℓ to obtain the overall solution.

The idea of tearing was introduced by Kron [1]. He applied the concept to solve a certain class of networks. His derivation of the approach is based on the concepts from tensor analysis. Happ [2] has expanded the theory and applications along the same line. Kron's derivation is obscure. Branin [3] has attempted to clarify the concepts. Recently Chua and Chen [4] have shown that diakoptics can be derived from the generalized hybrid analysis.

Kron introduced the idea of diakoptics to solve a network by first removing some branches. We present a simple derivation to remove the mystery caused by the previous derivations of diakoptics. We view the basic idea of diakoptics as merely the partition of the branches and the Kirchhoff laws. Our version of diakoptics is more general and includes all the previous results as special cases.

Diakoptics was developed as an approach to solve large-scale networks. In practice large-scale networks are usually sparsely connected. We present a solution algorithm for diakoptic analysis which incorporates sparse matrix techniques [5,6]. The solution algorithm can be applied provided a generic condition on the network is satisfied. If the network may be "torn apart," then the algorithm can be carried out using parallel computation scheme or series computation scheme.

It has been questioned as to whether the diakoptic approach always saves computation, if the sparse matrix techniques are employed. We use an example to demonstrate that as to the total number of computation, diakoptics may or may not save. We also present a special case where diakoptics does not save computation.

II. Diakoptic node analysis

Let \mathcal{N} be a connected network having $(n+1)$ nodes, $v = \{n_0, n_1, \dots, n_n\}$, and b branches, $\beta = \{b_1, b_2, \dots, b_b\}$, with linear time-invariant elements and sinusoidal sources. Consider the network \mathcal{N} in the sinusoidal steady-state.¹ Phasor notations will be used throughout this paper. Let the branch voltages and currents be denoted by $v = (v_1, v_2, \dots, v_b)$ and $i = (i_1, i_2, \dots, i_b)$, respectively. In the node analysis [7] one node is selected as the datum node.² The n node-to-datum voltages $V = (V_1, V_2, \dots, V_n)$ are used as network variables. The basic idea of tearing is to discriminate certain branches, henceforth called tearing branches,³ against the remaining branches. The set of branches β is thus partitioned into two classes, β_t and β_r . We use subscript r and t to denote quantities pertaining to

¹We assume that the sinusoidal steady-state response of \mathcal{N} exists. In fact, assumption 2 guarantees it.

²Our terminologies and most of the notations agree with ref. 7.

³Any subset of branches may be chosen as tearing branches in our derivation. However to achieve the computational advantages it is desired to choose those branches whose removal will tear the network apart.

the remaining branches and the tearing branches, respectively, e.g.,
 $v = (v_r, v_t)$ and $i = (i_r, i_t)$.

Each branch is assumed to have the general form shown in Fig. 2 [7, pp. 409-414]. Each branch in general includes a voltage source v_{sk} and a current source i_{sk} , and mutual coupling may exist between branches. We shall however make the following assumption, which is desirable from computational viewpoint [8, Remark 2], though it is not necessary for the derivation.

Assumption 1 There is no mutual coupling between the tearing branches and the remaining branches.

Let y_r denote the branch admittance matrix of the remaining branches and z_t denote the branch impedance matrix of the tearing branches. The branch relations are expressed as:

$$\begin{cases} i_r = i_{sr} + y_r v_r - y_r v_{sr} \\ v_t = v_{st} + z_t i_t - z_t i_{st} \end{cases}$$

Let us also partition the set of nodes v . If the removal of the tearing branches results in many separate parts,⁴ one of them contains the original datum node; for all the other separate parts, we pick a node from each of them.⁵ Let v_c denote the set of all these nodes.⁶

Let v_o denote the set of all other nodes. Hence v is partitioned into v_o and v_c . We use subscript o and c to denote quantities pertaining to

⁴ A maximal connected subnetwork of an unconnected network is called a separate part [7, p.387].

⁵ If a separate part contains more than one node, then the choice of the node can be arbitrary. However it may be desirable to pick one among the nodes which are connected by the tearing branches (See footnote 12).

⁶ As will be clear later, the node voltages associated with v_c will be calculated at the interconnection level, and v_o contains all the other nodes.

v_o and v_c respectively, hence $V = (V_o, V_c)$. The set of nodes that are connected only by the tearing branches is a subset of v_c .⁷ For our later reference, we denote this set of nodes by v_{c2} and denote the complement of v_{c2} with respect to v_c by v_{c1} .

The foregoing partition of branches and nodes gives rise to a natural partition of the reduced incidence matrix A,⁸

$$A = \begin{array}{c} v_o \\ v_c \end{array} \begin{array}{cc} \beta_r & \beta_t \\ \hline A_r & A_t \\ \hline a_r & a_t \end{array}$$

The network variables are constrained by the Kirchhoff current law (KCL), Kirchhoff voltage law (KVL), and the branch relations (BR). The constraints in node analysis are expressed as follows:

$$(KCL) \quad \begin{cases} A_r i_r + A_t i_t = 0 & (1) \\ a_r i_r + a_t i_t = 0 & (2) \end{cases}$$

$$(KVL) \quad \begin{cases} v_r = A_r^T V_o + a_r^T V_c & (3) \\ v_t = A_t^T V_o + a_t^T V_c & (4) \end{cases}$$

$$(BR) \quad \begin{cases} i_r = i_{sr} + y_r v_r - y_r v_{sr} & (5) \\ v_t = v_{st} + z_t i_t - z_t i_{st} & (6) \end{cases}$$

⁷ An isolated node is a separate part.

⁸ The rows of A correspond to the nodes (deleting the datum) and the columns of A correspond to the branches [7,p.417].

We shall call the network resulted from \mathcal{N} by removing all the tearing branches and the nodes in v_{c2} , the torn-network of \mathcal{N} .

Remark 1 Suppose v_{c2} is empty.⁹ The KCL, KVL, and BR for the torn-network are expressed as:

$$(KCL) \quad \begin{cases} A_r i_r = 0 \\ a_r i_r = 0 \end{cases} \quad \begin{matrix} (7) \\ (8) \end{matrix}$$

$$(KVL) \quad v_r = A_r^T V_o + a_r^T V_c \quad (9)$$

$$(BR) \quad i_r = i_{sr} + y_r v_r - y_r v_{sr} \quad (10)$$

The standard procedure for node analysis in this case is to substitute (9) into (10), and then substitute the result into (7) and (8) to obtain equations of the variables V .

Since the idea of tearing involves solving the torn network as the first step, let us compare eqs. (7) (8) (9) (10) with (1) (2) (3) (5). This suggests the following procedure: We substitute (3) into (5) and then substitute the result into (1) and (2) to obtain eqs (11) and (13) below. The remaining two equations (4) and (6) are combined into eq. (12) below

$$A_r y_r A_r^T V_o + A_t i_t + A_r y_r a_r^T V_c = J_o \quad (11)$$

$$A_t^T V_o - z_t i_t + a_t^T V_c = E \quad (12)$$

$$a_r y_r A_r^T V_o + a_t i_t + a_r y_r a_r^T V_c = J_c \quad (13)$$

⁹This assumption is only for notational convenience, otherwise J_c in eq. (8) would be J_{c1} , etc.

or

$$\begin{bmatrix} A_{rr}A_r^T & A_t & A_{rr}a_r^T \\ A_t^T & -z_t & a_t^T \\ a_{rr}A_r^T & a_t & a_{rr}a_r^T \end{bmatrix} \begin{bmatrix} v_o \\ i_t \\ v_c \end{bmatrix} = \begin{bmatrix} J_o \\ E \\ J_c \end{bmatrix} \quad (14)$$

where $J_o \triangleq A_{rr}v_{sr} - A_r i_{sr}$, $J_c \triangleq a_{rr}v_{sr} - a_r i_{sr}$ and $E \triangleq v_{sk} - z_t i_{st}$.

Equation (14) will be referred to as the diakoptic node equation. The process of arriving eq. (14) and the solution of it will be referred to as the diakoptic node analysis.

Remark 2 The diakoptic node equation may also be derived from block Gaussian elimination. Equations (10)-(6) are rearranged as:

I		$-y_r$			
	I		$-A_t^T$		$-a_t^T$
		I	$-A_r^T$		$-a_r^T$
A_r				A_t	
	I			$-z_t$	
a_r				a_t	

i_r
v_t
v_r
v_o
i_t
v_c

$i_{sr} - y_r v_{sr}$
0
0
0
$v_{st} - z_t i_{st}$
0

(15)

Block Gaussian elimination yields:

I		$-y_r$			
	I		$-A_t^T$		
		I	$-A_r^T$		$-a_r^T$
			$A_{rr}A_r^T$	A_t	$A_{rr}a_r^T$
			A_t^T	$-z_t$	a_t^T
			$a_{rr}A_r^T$	a_t	$a_{rr}a_r^T$

i_r
v_t
v_r
v_o
i_t
v_c

$i_{sr} - y_r v_{sr}$
0
0
J_o
E
J_c

(16)

Thus, eq. (16) is equivalent to eqs. (1)-(6) because the former is obtained from the latter by elementary row operations. Note that the lower right part of eq. (16) gives eq. (14).

Remark 3 Equation (14) can also be expressed as

$$\begin{bmatrix} A_{r'r} y_r A_r^T & A_t & A_{r'r} y_r a_r^T \\ A_t^T & -z_t & a_t^T \\ a_{r'r} y_r A_r^T & a_t & a_{r'r} y_r a_r^T \end{bmatrix} \begin{bmatrix} v_o \\ j_t \\ v_c \end{bmatrix} = \begin{bmatrix} J'_o \\ 0 \\ J'_c \end{bmatrix} \quad (14')$$

where $j_t \triangleq i_t - i_{st} + z_t^{-1} v_{st}$,

$$J'_o \triangleq -A_r i_{sr} + A_{r'r} y_r v_{sr} - A_t i_{st} + A_t z_t^{-1} v_{st} \quad \text{and}$$

$$J'_c \triangleq -a_r i_{sr} + a_{r'r} y_r v_{sr} - a_t i_{st} + a_t z_t^{-1} v_{st} .$$

If we first transform all the voltage sources into current sources [7, p. 413], the equivalent current sources for the tearing branches (resp. remaining branches) are $i_{st} - z_t^{-1} v_{st}$ (resp. $i_{sr} - y_r v_{sr}$). Thus j_t is the set of currents in the nonsource elements of the tearing branches, and each element of J'_o (resp. J'_c) is the sum of all the equivalent current sources at the corresponding node of v_o (resp. v_c).

Remark 4 The coefficient matrix of eq. (14) is easy to form. Note that the following four blocks

$A_{r'r} y_r A_r^T$	$A_{r'r} y_r a_r^T$
$a_{r'r} y_r A_r^T$	$a_{r'r} y_r a_r^T$

(17)

are precisely the node admittance matrix of the torn network. It can be formed by the standard procedure.¹⁰ The other five blocks are immediately obtained from the reduced incidence matrix and the branch relations.

Remark 5 If v_c is empty, the diakoptic node equation reduces to a simpler form [8]. This special case was considered by Kron [1]. Another special case is that v_{c2} is empty. This was considered by Happ [9]. However they arrived at different set of equations. Our general derivation may include the case where there are nodes connected by the tearing branches only, e.g. the network shown in Fig. 3. This enlarges the applicability of diakoptics.

III. Solution algorithm

We will present a solution algorithm for the diakoptic node eq. (14). Diakoptics is developed for the solution of large-scale networks. In practice large-scale networks are usually very sparsely connected. Our solution algorithm incorporates the sparse matrix techniques.

Sparse matrix equation is normally solved by the optimally-ordered Gaussian elimination or, equivalently, the LU-decomposition [10]. For a nonsingular matrix A the existence of an LU-decomposition is not guaranteed unless we allow row and column permutations [10; 11, pp. 31-34]. We will first show that if a generic condition on the network is satisfied, then the coefficient matrix of eq. (14), with the present partition of rows and columns, is block LU-decomposable. In other words, the equation may

¹⁰For networks without coupling, see [7,p.429]. Modification is needed to take care of the coupling.

be solved by LU-decomposition or Gaussian elimination with the three sets of equations (11) (12) (13) in that order and three sets of variables (v_o, i_t, v_c) in that order.¹¹

Let \mathcal{N}_a be the network derived from \mathcal{N} by coalescing all the nodes of v_c with the datum node (i.e., forcing the node voltages at v_c to be zero). Let \mathcal{N}_b be the network derived from \mathcal{N}_a by removing all the tearing branches.

Assumption 2 All the natural frequencies of the networks \mathcal{N} , \mathcal{N}_a and \mathcal{N}_b have nonzero and negative real parts.

Remark 6 We say that S_1 is a natural frequency of the network variable x , if, for some initial state; $K_1 e^{S_1 t}$ ($K_1 \neq 0$) appears in the expression for the zero-input response of x . We say that S is a natural frequency of a network if S a natural frequency of some voltage or a natural frequency of some current in the network [7, pp. 583-628]. The assumption that all the natural frequencies have nonzero and negative real parts implies that the zero-input response of the branch voltages and the branch currents all goes to zero at steady-state ($t \rightarrow \infty$). Physically this means that the network is lossy in the sense that without any input the stored energy will be dissipated and eventually goes to zero. The assumption is also sufficient to guarantee the existence of sinusoidal steady-state solution [7, p. 285].

Theorem 1 Consider a linear time-invariant RLC network \mathcal{N} with sinusoidal inputs. If Assumption 2 holds, then the coefficient matrix of the

¹¹Note that the LU-decomposition does not exist if we interchange the second block rows and the third block of rows, and also the second block of columns and the third block of columns.

diakoptic node eq. (14) is block LU-decomposable.

The proof of Theorem 1 is in the Appendix. With Theorem 1 as a guarantee, we may derive a solution algorithm based on the block LU-decomposition or gaussian elimination. In the derivation of the solution algorithm we make use of the following Fact, whose proof is also in the Appendix.

$$\text{Fact 1} \quad a_{r'r} a_r^T - a_{r'r} A_r^T (A_{r'r} A_r^T)^{-1} A_{r'r} a_r^T = 0 \quad (18)$$

To simplify notations, let $Y_{oo} \triangleq A_{r'r} A_r^T$, $Y_{oc} \triangleq A_{r'r} a_r^T$, and $Y_{co} \triangleq a_{r'r} A_r^T$. Let us first LU-decompose Y_{oo} ,

$$Y_{oo} = LU \quad (19)$$

Equation (11) becomes

$$U V_o = L^{-1} J_o - L^{-1} A_t i_t - L^{-1} Y_{oc} V_c \quad (20)$$

Substituting (19) into (12), we have

$$(z_t + A_t^T U^{-1} L^{-1} A_t) i_t = E + A_t^T U^{-1} L^{-1} J_o + [a_t^T - A_t^T U^{-1} L^{-1} Y_{oc}] V_c \quad (21)$$

Let us define

$$\phi_1 \triangleq L^{-1} A_t, \quad \phi_2 \triangleq L^{-1} Y_{oc}, \quad \psi_1 \triangleq A_t^T U^{-1}, \quad \psi_2 \triangleq Y_{co} U^{-1}, \quad \xi \triangleq L^{-1} J_o,$$

and

$$F \triangleq z_t + \psi_1 \phi_1 \quad (22)$$

Substituting (18), (20) and (21) into (13), we have

$$[(a_t - \psi_2 \phi_1) F^{-1} (a_t^T - \psi_1 \phi_2)] V_c = J_c - [\psi_2 \xi + (a_t - \psi_2 \phi_1) F^{-1} (\psi_1 \xi + E)] \quad (23)$$

Therefore, we may solve V_o , i_t , V_c in the following sequence:

(19)-(22)-(23)-(21)-(20). The procedure can also be derived from block LU-decomposition [8].

In the application of diakoptics, the case where the torn network has several "independent" subnetworks is of special interest. To be more specific, this is when the torn network is separable.¹² Let the torn network have k separable subnetworks $\mathcal{N}_1, \mathcal{N}_2, \dots, \mathcal{N}_k$. Let v_o (resp. β_r) be partitioned into k classes v_1, v_2, \dots, v_k (resp. $\beta_1, \beta_2, \dots, \beta_k$), where v_i (resp. β_i) is the intersection of v_o (resp. β_r) and the nodes (resp. branches) of \mathcal{N}_i . With this finer partition, we have $V_o = (V_1, V_2, \dots, V_k)$, $J_o = (J_1, J_2, \dots, J_k)$, and

$$A_r = \begin{array}{c} \beta_1 \quad \beta_2 \quad \dots \quad \beta_k \\ \begin{array}{|c|c|c|c|} \hline v_1 & A_1 & & \\ \hline v_2 & & A_2 & \\ \hline & & & \ddots \\ \hline v_k & & & & A_k \\ \hline \end{array} \end{array} \quad (24)$$

Suppose the following assumption holds.

Assumption 3 There is no mutual coupling between branches belonging to the different separable subnetworks.

Then the matrix Y_{oo} takes a block diagonal form:

¹²A network is separable if it has several separate parts and/or it is hinged [7, p. 445].

$$Y_{oo} = \begin{array}{|c|c|c|c|} \hline Y_1 & & & \\ \hline & Y_2 & & \\ \hline & & \ddots & \\ \hline & & & Y_k \\ \hline \end{array} \quad (25)$$

Let A_t , A_t^T , Y_{oc} , and Y_{co} be partitioned into $(A_t)_i$, $(A_t^T)_i$, $(Y_{oc})_i$, and $(Y_{co})_i$, $i = 1, 2, \dots, k$, accordingly. (Fig. 4a) Note that the matrix is in a desired bordered block diagonal form (Fig. 4b) [6, p. 20].

We may modify the previous solution procedure to take advantage of the decoupled block structure. Note that it is possible to perform computations of eqs. (19) (22) (20) for each subnetwork independently. We arrive at the following solution algorithm.

Solution algorithm

I. For each i , $i=1, 2, \dots, k$, do steps (S1) to (S6).

(S1) Input Y_i , $(Y_{oc})_i$, $(Y_{co})_i$, $(A_t)_i$, J_i

(S2) Factor $Y_i = L_i U_i$

(S3) Solve $L_i \phi_{1i} = (A_t)_i$ for ϕ_{1i} , $L_i \phi_{2i} = (Y_{oc})_i$ for ϕ_{2i} ;
 $\psi_{1i} U_i = (A_t^T)_i$ for ψ_{1i} , $\psi_{2i} U_i = (Y_{co})_i$ for ψ_{2i}

(S4) Solve $L_i \xi_i = J_i$ for ξ_i

(S5) Form $F_i = \psi_{1i} \phi_{1i}$, $G_i = \psi_{1i} \phi_{2i}$, $H_i = \psi_{2i} \phi_{1i}$
 $g_i = \psi_{1i} \xi_i$, $h_i = \psi_{2i} \xi_i$.

(S6) Output F_i , G_i , H_i , g_i , h_i

II. Do steps (C1) to (C8)

(C1) Input z_t , a_t , J_c , and F_i , G_i , H_i , g_i , h_i , $i = 1, 2, \dots, k$

- (C2) Form $F = z_t + \Sigma F_i$, $G = a_t^T - \Sigma G_i$, $H = a_t - \Sigma H_i$,
 $g = E + \Sigma g_i$ $h = \Sigma h_i$
- (C3) Solve $KF = H$ for K ,
- (C4) Form $P = KG$, $p = J_c - h - Kg$
- (C5) Solve $PV_c = p$ for V_c
- (C6) Form $f = g + GV_c$
- (C7) Solve $F i_t = f$ for i_t
- (C8) Output V_c, i_t

III. For each i , $i = 1, 2, \dots, k$, do steps (S7) to (S10).

- (S7) Input V_c, i_t
- (S8) Form $\zeta_i = \xi_i - \phi_{1i} i_t - \phi_{2i} V_c$
- (S9) Solve $U_i V_i = \zeta_i$ for V_i
- (S10) Output V_i .

Remark 7 The solutions of the triangular matrix equations in steps (S3), (S4), and (S9) are merely substitutions. Also note that since most of the columns of $(A_t)_i$ and $(Y_{oc})_i$, and the rows of $(Y_{co})_i$ are all zeros, the corresponding computations for these zero rows and columns in Steps (S3) and (S5) need not be performed. Furthermore, in practical applications, the dimensions of F and P are usually small.

Remark 8 Part I and part III of the solution algorithm can be carried out simultaneously for all the subnetworks. Therefore the algorithm can be implemented in a parallel computation scheme, for example, a computer network of the star configuration, i.e., several satellite computers (one for each subnetwork) linked together by a central computer. The satellite computers do parts I and III, and the central computer does

part II. (Fig. 5).¹³

Remark 9 Obviously part I and part III of the solution algorithm can also be carried out in a series computation scheme.

Remark 10 Part I of the algorithm corresponds to the "subnetwork level" of diakoptics mentioned in Sec. I and parts II and III correspond to the "interconnection level" of diakoptics.

Remark 11 If v_c is empty the algorithm reduces to a simpler version [8].

IV. Computational Considerations

Applying the conventional node analysis to the network \mathcal{N} , we arrive at the following equation:

$$\left\{ \begin{array}{cc} \left[\begin{array}{cc} A_r & A_t \\ a_r & a_t \end{array} \right] \left[\begin{array}{cc} y_r & 0 \\ 0 & z_t^{-1} \end{array} \right] \left[\begin{array}{cc} A_r^T & a_r^T \\ A_t^T & a_t^T \end{array} \right] \end{array} \right\} \begin{bmatrix} v_o \\ v_c \end{bmatrix} = \begin{bmatrix} J'_o \\ J'_c \end{bmatrix} \quad (26)$$

Where J'_o and J'_c are the equivalent current source vectors at v_o and v_c respectively, as defined in Remark 3. The coefficient matrix here is simply the node admittance matrix Y of \mathcal{N} . Both the conventional node analysis (solution of (26)) and the diakoptic node analysis (solution of (14)) give us the node voltages, naturally we would like to know which one requires less total computation to obtain the solution. For ease of later reference we will denote the matrix of eq. (14) by T .

¹³The central computer inputs data of the tearing branches, z_t and a_t , as well as J_c . In order to make all the components of J_c related to the tearing branches, c it may be desirable to select the set of nodes v_{c1} from those nodes that are connected by the tearing branches.

In what follows, we count only multiplications in the comparison.¹⁴

For large-scale network, the matrices Y and T are very sparse. In sparse matrix computation, operations involving zero are not performed. Consider solving the sparse system $Ax = b$, where A is $n \times n$ and $A = LU$, let l_i denote the number of nonzero elements in the i th column of L, and u_i denote the number of nonzero elements in the i th row of u. It can be shown [8,12], by simple counting, that the total number of (complex) multiplications required to solve $Ax = b$ is equal to $\sum_{i=1}^n (l_i+1)u_i - 2n$. Clearly the ordering of rows and columns of A affects greatly the l_i 's and u_i 's. There are several locally-optimal ordering schemes [5,6].

We are going to present an example of a network having a parameter p. Depending on the value of p, the number of multiplications required for the diakoptic node analysis may be less than, or greater than that for the conventional node analysis, both with optimal ordering.¹⁵ This clearly demonstrate that neither approach is absolutely superior to the other, as far as the total number of multiplications is concerned.

Example Consider the network shown in Fig. 6. Let all the branches be two-terminal elements (no mutual coupling). The branches connecting nodes d_i 's are defined as follows:

- (i) For all $3 \leq i \leq p$, $i < j \leq 2i$, there is a branch connecting nodes d_i and d_j .

¹⁴The formation of the matrices Y and T involves only additions. For node analysis, voltage sources have usually been transformed into current sources. Hence the formation of J' and J'_c involves only additions. We assume eq. (14'), instead of eq. (14), is used for diakoptic node analysis.

¹⁵We compare the computations required for the solution of the node voltages. Therefore the fact that the diakoptic approach gives, in addition to the node voltages, also the tearing-branch currents is not taken into account.

(ii) For all $p < i \leq 2p$, $i < j \leq 2p$, there is a branch connecting nodes d_i and d_j .

For the conventional node analysis, we first form the matrix Y , which has the same sparsity structure as the network \mathcal{N} , i.e., the ij th element of Y , U_{ij} , is nonzero iff there is a branch in \mathcal{N} connecting node i and node j . It can be shown that by applying any of the locally-optimal ordering schemes [5] to Y , the ordering $(a, b, c, d_3, d_4, \dots, d_{2p})$ will result. The nonzero pattern of Y , together with the fill-ins¹⁶ is shown in Fig. 7a. A little calculation shows that the total number of multiplications for the solution in this case is equal to

$$\gamma_p = 2 \sum_{k=1}^{p+2} k(k+1) - 4p - 66.$$

Now let us consider solving this problem by diakoptics. Suppose we pick the branches (b, d_3) , (c, d_{2p-2}) , (c, d_{2p-1}) and (c, d_{2p}) as the tearing branches t_1 , t_2 , t_3 , and t_4 , respectively. Let us form the matrix T . Again it can be shown that within their blocks, $(a, b, c, d_3, \dots, d_{2p})$ and (t_1, t_2, t_3, t_4) are optimally-ordered.¹⁷ The nonzero pattern of T , together with the fill-ins, is shown in Fig. 7b. The total number of multiplications to obtain the solution in this case is equal to

$$\delta_p = 2 \sum_{k=1}^{p+1} k(k+1) + (p+2)(p+3) - 4p + 88. \text{ Hence } (\gamma_p - \delta_p) = p^2 + 5p - 148.$$

If $p \geq 10$, $\gamma_p > \delta_p$, i.e., the diakoptic node analysis requires less multiplications. On the other hand, if $3 \leq p \leq 9$, $\gamma_p < \delta_p$, i.e., the diakoptic node analysis requires more multiplications.

¹⁶The ij th position is said to be a fill-in if $Y = LU$ and $Y_{ij} = 0$ but either the ij th element of L (if $i > j$), or of U (if $i < j$) is nonzero.

¹⁷The same letter, e.g. d_i , is used to denote the rows and columns corresponding to the node d_i for both Y and T .

It is rather difficult to find general conditions under which the diakoptic analysis saves computation. It is not because it rarely happens. In fact it happens only when the number of fill-ins introduced in the LU-decomposition of T is less than that of Y. Now the least number of fill-ins in the LU-decomposition of Y occurs when the rows and columns of Y are optimally-ordered. This optimal ordering may bear no relation to the ordering of T, which has a predetermined block ordering. Therefore the comparison is difficult.

On the other hand, for a very special case we show that the diakoptic analysis saves no computation.

Fact 2 Suppose that the network \mathcal{N} consisting of two-terminal elements.

Suppose a set of tearing branches is so chosen that

- (i) there is no node connected only by the tearing branches.
- (ii) the torn-network has k separable subnetworks hinged at the datum node.
- (iii) each of the separable subnetworks is complete.¹⁸
- (iv) there is an ordering of the subnetworks $\mathcal{N}_1, \mathcal{N}_2, \dots, \mathcal{N}_k$, such that the tearing branches only connect two adjacent subnetworks \mathcal{N}_i and \mathcal{N}_j , $1 \leq i < k$, $j = i+1$.

Then the diakoptic node analysis (14) requires more multiplications than the conventional node analysis.

The proof of Fact 2 is in the Appendix.

Remark 12 Assumptions (i) and (ii) are the same ones that were made by Kron. He used the node impedance matrix, which is full, i.e., it amounts to the assumption (iii). Assumption (iv) further restricts the

¹⁸ A network is complete if for each pair of nodes there is a branch connecting them.

tearing to a "cascaded" network configuration (Fig. 8).

V. Other Diakoptic and Codiakoptic Analyses

There are several standard network analysis procedures, namely, node analysis, mesh analysis, cutset analysis, loop analysis, and mixed analysis. Each of them provides a systematic way of writing linearly independent Kirchhoff laws. Once it is understood that diakoptics involves merely partition of branches and the Kirchhoff laws, similar derivation as in section II can be applied to other network analysis procedures. In the following, we will not repeat the obvious similarities. Only the diakoptic mixed analysis is derived in some detail. We call the dual of a diakoptic analysis codiakoptic analysis [13].

1 Diakoptic cutset analysis

Given a tree of the network \mathcal{N} , the set of tree branches can be partitioned into two classes; i.e., those of the remaining branches and those of the tearing branches. The set of tree-branch voltages, which are the network variables in this case, is partitioned into V_r and V_t , accordingly. Also the set of fundamental cutsets γ is partitioned into γ_r and γ_t . Hence the fundamental cutset matrix Q takes the form:

$$Q = \begin{array}{c} \beta_r \quad \beta_t \\ \gamma_r \quad \gamma_t \end{array} \begin{array}{|c|c|} \hline Q_r & Q_t \\ \hline q_r & q_t \\ \hline \end{array} \quad (27)$$

Note that if we choose a tree such that it contains as many remaining branches as possible then $q_r = 0$. On the other hand, if we choose a tree

such that it contains as many tearing branches as possible then $Q_t = 0$.

2 Codiakoptic mesh analysis

This is the dual of the idakoptic node analysis for a planar network. Consider the set of meshes μ . If the tearing branches form loops, we pick a mesh from the region enclosed by such a loop. Let μ_c denote the collection of such meshes. Let μ_o denote the set of other meshes. Hence μ is partitioned into μ_o and μ_c and the reduced mesh matrix M takes the form

$$M = \begin{array}{c} \mu_o \\ \mu_c \end{array} \begin{array}{cc} \beta_r & \beta_t \\ \hline M_r & M_t \\ \hline m_r & m_t \end{array} \quad (28)$$

The dual torn network is defined as the network resulted from \mathcal{N} by contracting all the tearing branches.¹⁹ In order to have the dual torn network having several "independent" subnetworks, the set of tearing branches should be so chosen that the dual torn network has hinged subnetworks and the subnetworks are not mutually coupled. For a planar network the set of tearing branches having this property can be characterized as:

- (i) they divide the plane into several regions,
- (ii) there is no mutual coupling between branches belonging to different regions.

¹⁹ A branch is contracted if its two end nodes coalesced into one node and itself being removed.

3. Codiakoptic loop analysis

This is the dual of the diakoptic cutset analysis. Given a tree of \mathcal{N} , the set of link currents (the network variables for loop analysis) is partitioned into I_r and I_t . The fundamental loops ℓ are partitioned into ℓ_r and ℓ_t . Hence

$$B = \begin{array}{c} \beta_r \quad \beta_t \\ \begin{array}{|c|c|} \hline \ell_r & \begin{array}{cc} B_r & B_t \end{array} \\ \hline \ell_t & \begin{array}{cc} b_r & b_t \end{array} \\ \hline \end{array} \end{array} \quad (29)$$

Note that if we choose a tree such that it contains as many remaining (resp. tearing) branches as possible then $B_t = 0$ (resp. $b_r = 0$).

4. Diakoptic mixed analysis

The essence of mixed analysis is that a set of independent Kirchhoff law equations is selected from two network analysis formulations. We will base our derivation below on the mixed cutset and loop analysis. We will comment on the generality of the approach later.

Let us first pick a tree of \mathcal{N} such that it contains as many remaining branches as possible. Now we write down Kirchhoff laws for the cutset analysis and the loop analysis side by side:²⁰

	Cutset analysis		Loop analysis
(KCL)	$\begin{cases} Q_r i_r + Q_t i_t = 0 & (30) \\ q_t i_t = 0 & (32) \end{cases}$	$\begin{cases} i_r = B_r^T I_r + b_r^T I_t & (31) \\ i_t = b_t^T I_t & (33) \end{cases}$	
(KVL)	$\begin{cases} v_r = Q_r^T V & (34) \\ v_t = Q_t^T V_r + q_t^T V_t & (36) \end{cases}$	$\begin{cases} B_r v_r = 0 & (35) \\ b_r v_r + b_t v_t = 0 & (37) \end{cases}$	

²⁰Different trees may be chosen for the cutset analysis and the loop analysis so long as each tree contains maximal number of remaining branches.

$$(BR) \begin{cases} i_r = i_{sr} + y_r v_r - y_r v_{sr} & (38) \\ v_t = v_{st} + z_t i_t - z_t i_{st} & (39) \end{cases} \quad \begin{cases} i_r = i_{sr} + y_r v_r - y_r v_{sr} & (38) \\ v_t = v_{st} + z_t i_t - z_t i_{st} & (39) \end{cases}$$

Let \mathcal{N}_r denote a network derived from \mathcal{N} by removing all the tearing branches and \mathcal{N}_t denote a network derived from \mathcal{N} by contracting all the remaining branches. Note that both eq. (34) and eq. (35) are complete characterization of KVL constraints for the network \mathcal{N}_r , similarly both eq. (32) and eq. (33) are complete characterization of KCL constraints for the network \mathcal{N}_t [14]. Therefore, eqs. (30) and (33) form a complete set of KCL for \mathcal{N} and eqs. (34) and (37) form a complete set of KVL for \mathcal{N} . We thus proceed our analysis for \mathcal{N} with KCL constraints (30)-(33), KVL constraints (34) (37), and BR (38) (39).

Motivated by the cutset analysis on \mathcal{N}_r and the loop analysis on \mathcal{N}_t , we combine eqs. (30), (34), (38) and eqs. (33), (37), (39). We then eliminate i_t and v_r from the expressions by substituting eqs. (33) and (34). Thus we obtain:

$$\begin{bmatrix} Q_r y_r Q_r^T & Q_t b_t^T \\ b_r Q_r^T & b_t z_t b_t^T \end{bmatrix} \begin{bmatrix} v_r \\ i_t \end{bmatrix} = \begin{bmatrix} J_r \\ E_t \end{bmatrix} \quad (40)$$

where $J_r \triangleq Q_r y_r v_{sr} - Q_r i_{sr}$ and $E_t \triangleq b_t z_t i_{st} - b_t v_{st}$. Note that $b_r Q_r^T = -b_t Q_t^T$ as a consequence of Tellegen's theorem [7, p. 493]. We may interpret J_r and E_t as follows: Suppose we first transform the voltage (current) source associated with a remaining (tearing) branch into an equivalent current (voltage) source. Then $J_r(E_t)$ is the sum of all equivalent current (voltage) source in the fundamental cutsets (loops) defined by the remaining-branch-tree-branches (tearing-branch links).

Remark 13 Note that the cutset analysis eq. (30) just provides a set of linearly independent KCL for the network \mathcal{N}_t and eq. (34) provides a complete characterization of the KVL constraints for \mathcal{N}_t . We certainly may replace eq. (30) by a set of linearly independent KCL for \mathcal{N}_t supplied by the node analysis equations and also replace eq. (34) by the corresponding node voltage characterization of KVL constraints from node analysis.²¹ Similarly for planar networks, the loop analysis eqs. (33) and (37) may be replaced by the mesh analysis equations. Thus we may have diakoptic mixed node-and-loop (or node-and-mesh) analysis.

5. Codiakoptic mixed analysis

This is the dual of the diakoptic mixed analysis. Here we start by picking a tree of \mathcal{N} such that it contains as many tearing branches as possible.

²¹If there are several separate parts in \mathcal{N}_t , node analysis should be performed for each separate part.

References

- [1] G. Kron, Diakoptics: The Piecewise Solution of Large-Scale Systems, London: MacDonal, 1963. (A collection of papers appeared in the Electrical Journal from 1957 to 1959).
- [2] H. H. Happ, Diakoptics and Networks, New York: Academic Press, 1971.
- [3] F. H. Branin, "The relation between Kron's method and the classical methods of network analysis," The Matrix and Tensor Quarterly, vol. 12, March 1962, pp. 69-105.
- [4] L. O. Chua and L. K. Chen, "Nonlinear diakoptics," Technical Memo No. ERL-M495, Electronics Research Laboratory, Univ. of California, Berkeley, March 10, 1975.
- [5] W. F. Tinney and J. W. Walker, "Direct solutions of sparse network equations by optimally ordered triangular factorization," Proc. IEEE, vol. 55, pp. 1801-1809, Nov. 1967.
- [6] R. P. Tewarson, Sparse Matrices, New York: Academic Press, 1973.
- [7] C. A. Desoer and E. S. Kuh, Basic Circuit Theory, New York: McGraw-Hill, 1969.
- [8] F. F. Wu, "Diakoptics and triangular factorization," IEEE paper #C75 107-8, presented at IEEE Power Engineering Society Winter Meeting, New York, Jan. 26-31, 1975.
- [9] H. H. Happ, "Diakoptics -- the solution of system problems by tearing," Proc. of IEEE, vol. 62, July 1974, pp. 930-940.
- [10] L. O. Chua and P. M. Lin, Computer-Aided Analysis of Electronic Circuits: Algorithms and Computational Techniques, Prentice-Hall, Englewood Cliffs, N. J., 1975.
- [11] E. Isaacson and H. B. Keller, Analysis of Numerical Methods, New York: John-Wiley, 1966.

- [12] J. R. Bunch and D. J. Rose, "Partitioning, tearing and modification of sparse linear systems," Cornell Univ, Dept. of Comp. Sci. Tech. Report, TR72-149, Nov. 1972.
- [13] R. Onodera, "Diakoptics and codiakoptics of electric network," RAAG Memoirs, vol. 2, 1958, pp. 369-388.
- [14] F. F. Wu, "Algebraic formulation of Kirchhoff laws," Proc. 1973 Int. Symp. on Circuits and Systems, April 1973, pp. 101-104.

Footnotes

¹We assume that the sinusoidal steady-state response of \mathcal{N} exists. In fact, assumption 2 guarantees it.

²Our terminologies and most of the notations agree with ref. 7.

³Any subset of branches may be chosen as tearing branches in our derivation. However to achieve the computational advantages it is desired to choose those branches whose removal will tear the network apart.

⁴A maximal connected subnetwork of an unconnected network is called a separate part [7,p.387].

⁵If a separate part contains more than one node, then the choice of the node can be arbitrary. However it may be desirable to pick one among the nodes which are connected by the tearing branches (see footnote 12).

⁶As will be clear later, the node voltages associated with v_c will be calculated at the interconnection level, and v_o contains all the other nodes.

⁷An isolated node is a separate part.

⁸The rows of A correspond to the nodes (deleting the datum) and the columns of A correspond to the branches [7,p.417].

⁹This assumption is only for notational convenience, otherwise J_c in eq. (8) would be J_{c1} , etc.

¹⁰For networks without coupling, see [7,p.429]. Modification is needed to take care of the coupling.

¹¹Note that the LU-decomposition does not exist if we interchange the second block rows and the third block of rows, and also the second block of columns and the third block of columns.

¹²A network is separable if it has several separate parts and/or it is hinged [7,p.445].

¹³The central computer inputs data of the tearing branches, z_t and a_t , as well as J_c . In order to make all the components of J_c related to the tearing branches, it may be desirable to select the set of nodes v_{c1} from those nodes that are connected by the tearing branches.

¹⁴The formation of the matrices Y and T involves only additions. For node analysis, voltage sources have usually been transformed into current sources. Hence the formation of J'_o and J'_c involves only additions. We assume eq. (14'), instead of eq. (14), is used for diakoptic node analysis.

¹⁵We compare the computations required for the solution of the node voltages. Therefore the fact that the diakoptic approach gives, in addition to the node voltages, also the tearing-branch currents is not taken into account.

¹⁶The ijth position is said to be a fill-in if $Y = LU$ and $Y_{ij} = 0$ but either the ijth element of L (if $i > j$), or of U (if $i < j$) is nonzero.

¹⁷The same letter, e.g. d_i , is used to denote the rows and columns corresponding to the node d_i for both Y and T.

¹⁸A network is complete if for each pair of nodes there is a branch connecting them.

¹⁹A branch is contracted if its two end nodes coalesced into one node and itself being removed.

²⁰Different trees may be chosen for the cutset analysis and the loop analysis so long as each tree contains maximal number of remaining branches.

²¹If there are several separate parts in \mathcal{N}_t , node analysis should be performed for each separate part.

Appendix

(A) Proof of Theorem 1.

We claim that the coefficient matrix of the diakoptic equation (14) is nonsingular, i.e.,

$$\begin{bmatrix} A_{rr}y_rA_r^T & A_t & A_{ry}y_r a_r^T \\ A_t^T & -z_t & a_t^T \\ a_{ry}y_r A_r^T & a_t & a_{ry}y_r a_r^T \end{bmatrix} \begin{bmatrix} \bar{v}_o \\ \bar{i}_t \\ \bar{v}_c \end{bmatrix} = \begin{bmatrix} 0 \\ 0 \\ 0 \end{bmatrix} \quad (A1)$$

implies $\bar{v}_o = 0$, $\bar{i}_t = 0$, and $\bar{v}_c = 0$.

Comparing (A1) with eq. (15), we notice that (\bar{v}_o, \bar{v}_c) and \bar{i}_t are the zero-input steady-state response²² of the node voltages and the tearing branch currents, respectively, of the network \mathcal{N} . Since the natural frequencies of \mathcal{N} have nonzero and negative real parts, all the branch voltages and branch currents are zero at steady-state, in particular, $\bar{i}_t = 0$, $\bar{v}_r = 0$, and $\bar{v}_t = 0$. Hence from eq. (3) (4),

$$\begin{bmatrix} 0 \\ 0 \end{bmatrix} = \begin{bmatrix} \bar{v}_r \\ \bar{v}_t \end{bmatrix} = A^T \begin{bmatrix} \bar{v}_o \\ \bar{v}_c \end{bmatrix} \quad (A2)$$

Because \mathcal{N} is connected, A is of full rank. It follows from (A2) that $\bar{v}_o = 0$, and $\bar{v}_c = 0$.

Now we know the coefficient matrix of (A1) has a LU-decomposition, possibly after some row and column permutations.

Next note that the matrix of (A1) has a block LU-decomposition, as follows:

²²The existence of steady-state response is guaranteed by the Assumption 2.

$$\begin{aligned}
& \begin{bmatrix} A_{r_r} y_r A_{r_r}^T & A_t & A_{r_r} y_r a_r^T \\ A_t^T & -z_t & a_t^T \\ a_{r_r} y_r A_{r_r}^T & a_t & a_{r_r} y_r a_r^T \end{bmatrix} \\
= & \begin{bmatrix} I & & 0 & & 0 \\ A_t^T Y^{-1} & & I & & 0 \\ a_{r_r} y_r A_{r_r}^T Y^{-1} & & -[a_t - a_{r_r} y_r A_{r_r}^T Y^{-1} A_t] Y^{-1} & & I \end{bmatrix} \begin{bmatrix} Y & A_t & A_{r_r} y_r a_r^T \\ 0 & -F & a_t^T - A_t^T Y^{-1} A_{r_r} y_r a_r^T \\ 0 & 0 & P \end{bmatrix} \quad (A3)
\end{aligned}$$

if Y and F are nonsingular, where

$$Y \stackrel{\Delta}{=} A_{r_r} y_r A_{r_r}^T \quad (A4)$$

$$F \stackrel{\Delta}{=} z_t + A_t^T Y^{-1} A_t \quad (A5)$$

$$\begin{aligned}
P \stackrel{\Delta}{=} & [a_t - a_{r_r} y_r A_{r_r}^T Y^{-1} A_t] F^{-1} [a_t^T - A_t^T Y^{-1} A_{r_r} y_r a_r^T] \\
& + a_{r_r} y_r a_r^T - a_{r_r} y_r A_{r_r}^T Y^{-1} A_{r_r} y_r a_r^T \quad (A6)
\end{aligned}$$

Note that the nonsingularity of Y and F , together with that of the coefficient matrix, implies that P is nonsingular. To show that Y is nonsingular, i.e., $Y \bar{V}_0 = 0$ implies $\bar{V}_0 = 0$, note that $Y \bar{V}_0 = 0$ implies that \bar{V}_0 is the zero-input steady-state response of the node voltages of \mathcal{N}_b . Since \mathcal{N}_b is connected and has all the natural frequencies lying in the open left half of the complex plane, the same arguments lead to the conclusion $\bar{V}_0 = 0$. To show that F is nonsingular, i.e., $[z_t + A_t^T Y^{-1} A_t] \bar{i}_t = 0$ implies $\bar{i}_t = 0$, let us define

$$\bar{V}_0 = -Y^{-1} A_t \bar{i}_t \quad (A7)$$

Hence $[z_t + A_t^T Y^{-1} A_t] \bar{i}_t = 0$ becomes

$$\begin{bmatrix} A_r y_r A_r^T & A_t \\ A_t^T & -z_t \end{bmatrix} \begin{bmatrix} \bar{v}_o \\ \bar{i}_t \end{bmatrix} = \begin{bmatrix} 0 \\ 0 \end{bmatrix} \quad (\text{A8})$$

Therefore \bar{i}_t is the zero-input steady-state response of the tearing branch currents of \mathcal{N}_a . The fact that the natural frequencies of \mathcal{N}_a have nonzero, negative real part implies that $\bar{i}_t = 0$. The proof is thus complete.

(B) Proof of Fact 1

We first prove the fact that each row of a_r is a linear combination of the rows of A_r , i.e., $a_r = CA_r$.

Consider a row in a_r , which corresponds to a node in v_{c1} , i.e., this row is associated with the node which is picked from a separate part \mathcal{N}_i of the torn-network. This row is indeed the negative of the sum of those rows in A_r that correspond to the nodes in \mathcal{N}_i , because all these rows together form the (unreduced) incidence matrix of \mathcal{N}_i . Next consider a row in a_r that corresponds to a node in v_{c2} . It is a zero row, which is a trivial linear combination of the rows of A_r . Hence, $a_r = CA_r$.

(18) and obtain

$$\begin{aligned} a_r y_r a_r^T - a_r y_r A_r^T (A_r y_r A_r^T)^{-1} A_r y_r a_r^T \\ = CA_r y_r A_r^T C^T - CA_r y_r A_r^T (A_r y_r A_r^T)^{-1} A_r y_r A_r^T C^T = 0 \end{aligned}$$

(C) Proof of Fact 2

Since both Y and T have symmetrical nonzero pattern, it suffices to consider the nonzero elements in the columns of the lower triangular matrix. We first claim that to each nonzero element of Y in the j th column there is a corresponding one in T . This is so because if $Y_{ij} \neq 0$

and $T_{ij} = 0$ then (i,j) must be a tearing branch t , hence $T_{tj} \neq 0$.

Next we claim that to every fill-in introduced in the decomposition of Y there is a corresponding one in the same column of T . Let us write down the formula for the LU-decomposition to establish the notations. For $Y = LU$, let

$$Y_{ij}^1 = Y_{ij}$$

$$Y_{ij}^{m+1} = Y_{im}^m - Y_{im}^m Y_{mj}^m \quad m = 1, 2, \dots, n-1; i > m, j > m.$$

$$L_{ij} = Y_{ij}^j, \quad i \geq j$$

$$U_{ij} = Y_{ij}^j / Y_{ii}^i, \quad i < j$$

Similarly for T . Note that a fill-in is introduced in Y if $Y_{ij}^m = 0$ and $Y_{ij}^{m+1} \neq 0$. This implies that $Y_{im}^m \neq 0$ and $Y_{mj}^m \neq 0$. Note that the fill-ins of Y only occur between two adjacent diagonal blocks. To be specific, let the row and column indices $(\alpha+1, \dots, \beta)$ correspond to \mathcal{N}_α and $(\beta+1, \dots, \gamma)$ correspond to the adjacent $\mathcal{N}_{\alpha+1}$, then the fill-in of Y at ij , such that $\beta < i \leq \gamma$, occurs only when $\alpha < j \leq \beta$ (Fig. 9).

Now we will show inductively on m that Y_{ij}^{m+1} is a fill-in of Y implies that there is a t such that T_{tj}^{m+1} is a fill-in of T . Certainly it is true for $m = \alpha+1$. Suppose it is true for $m < \ell \leq \beta$, and Y_{ij}^{m+1} is a fill-in, hence $Y_{im}^m \neq 0$ and $Y_{mj}^m \neq 0$. Clearly $T_{mj}^m \neq 0$. If $T_{im}^m = 0$, by induction hypothesis there is a t such that $T_{tm}^m \neq 0$, hence $T_{tj}^{m+1} \neq 0$. Moreover $Y_{ij}^m = 0$ implies $T_{tj}^m = 0$, hence T_{tj}^{m+1} is indeed a fill-in of T . The proof is thus complete.

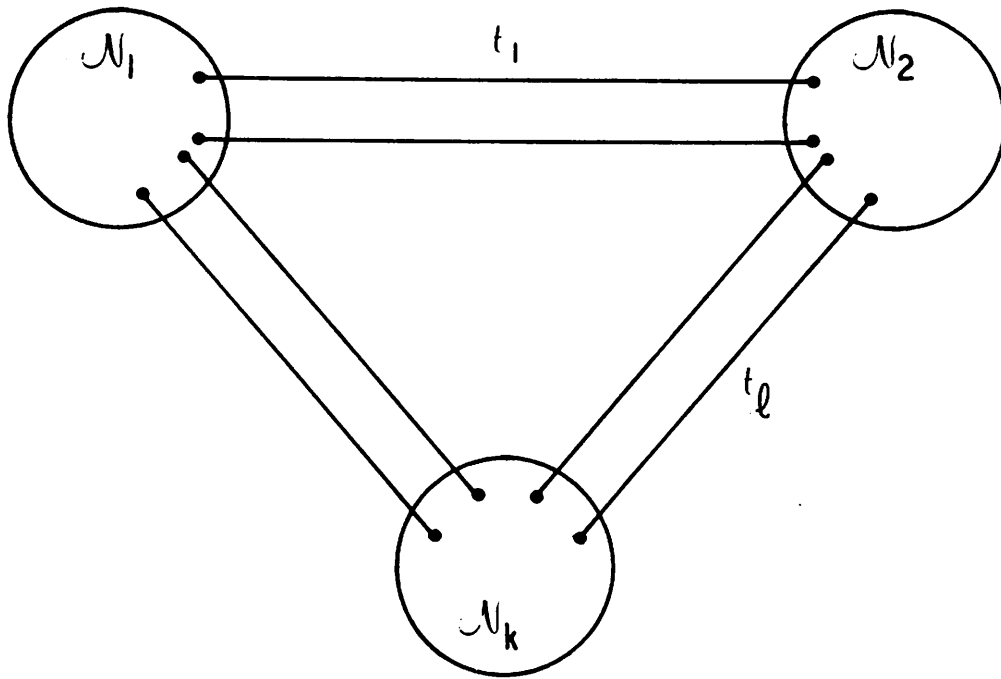

Fig. 1. Networks from which the idea of tearing originated.

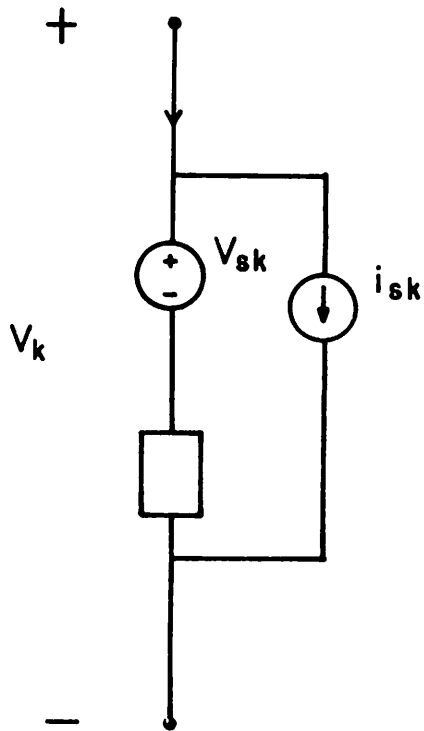

Fig. 2. A generalized branch k , which includes a voltage source and a current source. The voltage and current relation for the nonsource element in the box is given by the impedance or the admittance (coupling allowed).

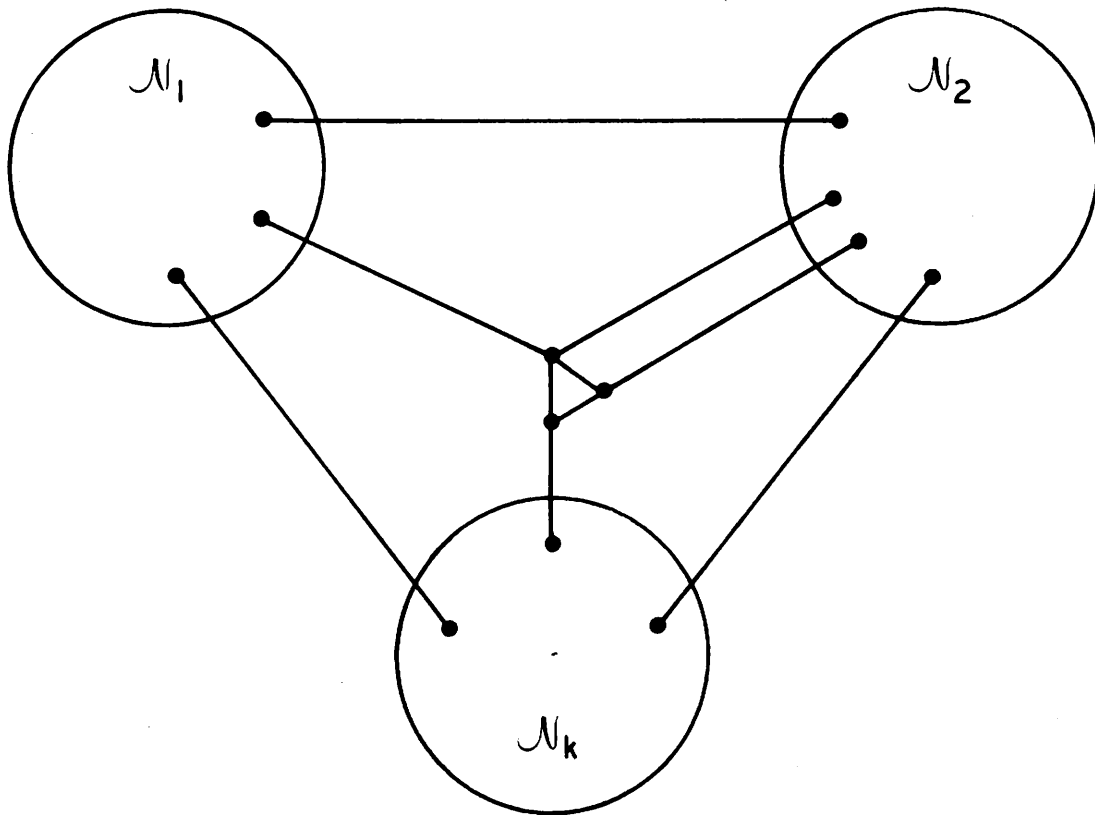
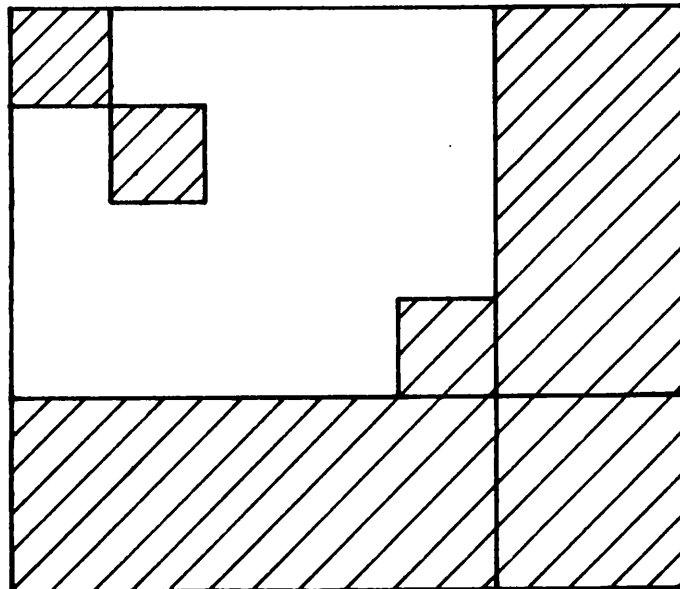

Fig. 3. The diakoptic analysis in this paper also applied to networks that have nodes connected only by the tearing branches.

Y_1				$(A_t)_1$	$(Y_{oc})_1$
	Y_2			$(A_t)_2$	$(Y_{oc})_2$
				\vdots	\vdots
			Y_k	$(A_t)_k$	$(Y_{oc})_k$
$(A_t^T)_1$	$(A_t^T)_2$	\cdots	$(A_t^T)_k$	$-z_t$	a_t^T
$(Y_{co})_1$	$(Y_{co})_2$	\cdots	$(Y_{co})_k$	a_t	Y_{cc}

(a)



(b)

Fig. 4. (a) Partition of the coefficient matrix according to the k separable subnetworks.

(b) Bordered block diagonal form. The unshaded area consists of all zeros.

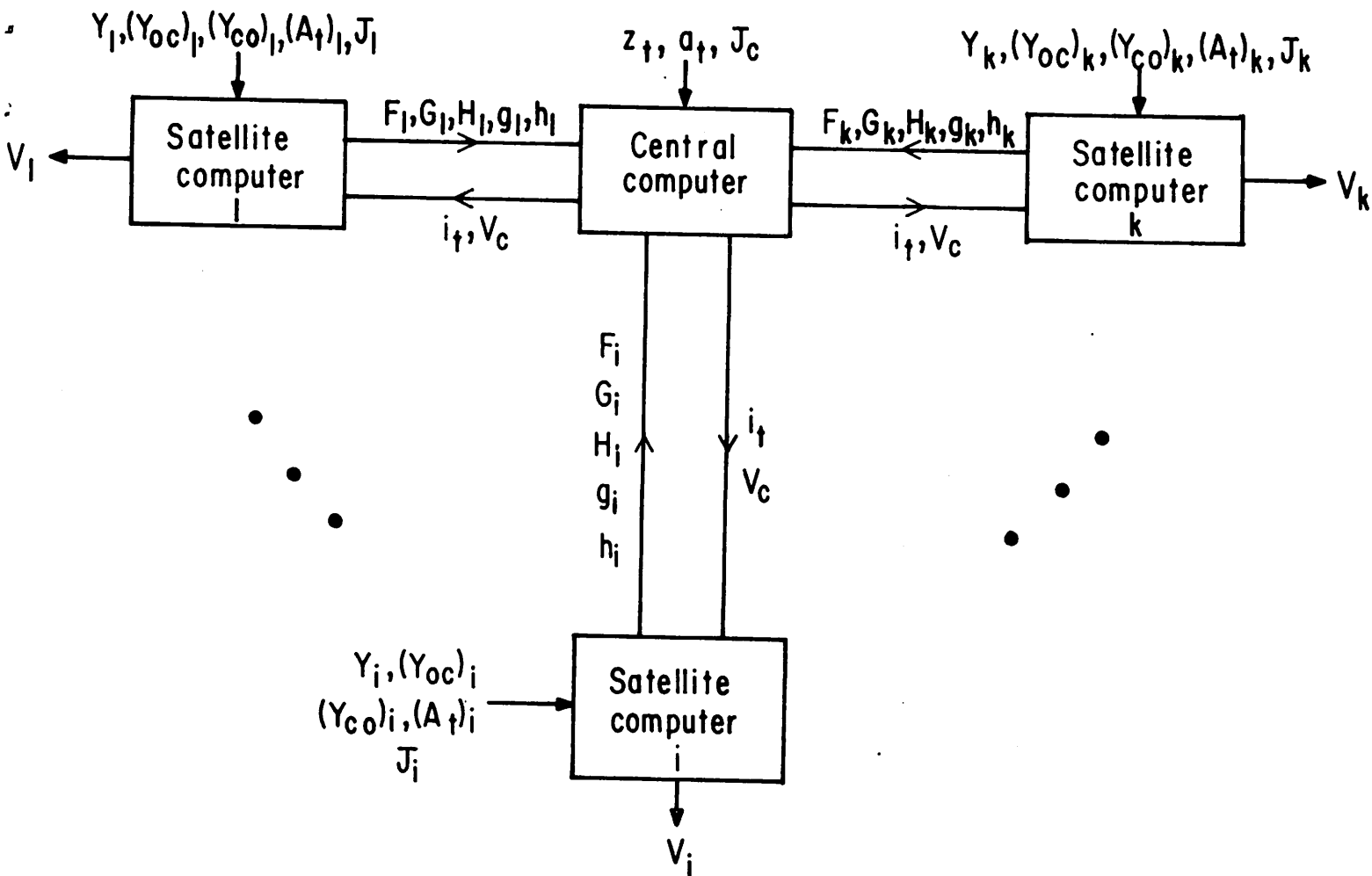

Fig. 5. A parallel computation scheme for diakoptics with data flow indicated.

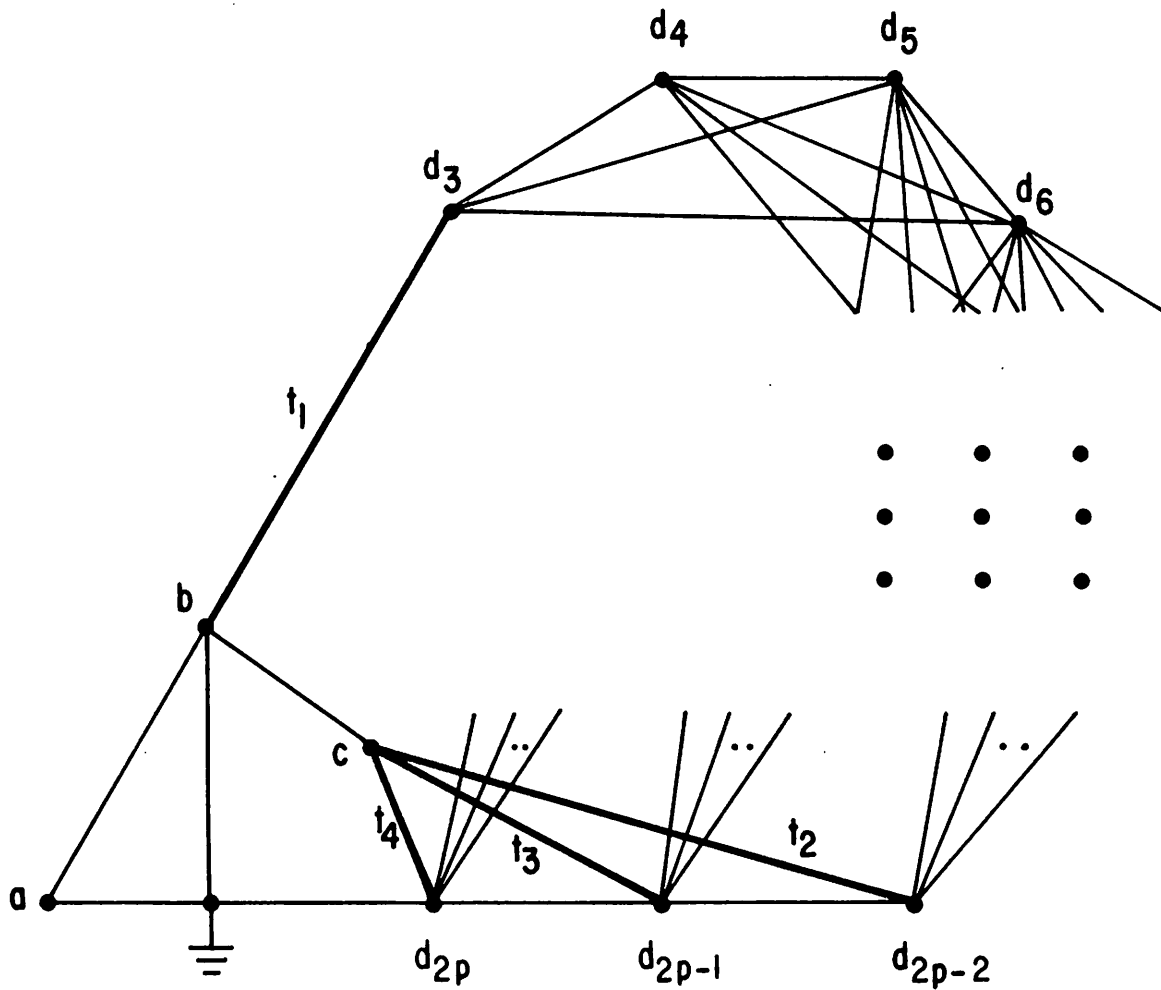

Fig. 6. Network for the example. Branches in heavy lines are tearing branches.

	a	b	c	d ₃	d ₄													d ₁₉	d ₂₀
a	X	X																	
b	X	X	X	X															
c		X	X	F													X	X	X
d ₃		X	F	X	X	X	X										F	F	F
d ₄				X	X	X	X	X	X								F	F	F
				X	X	X	X	X	X	X	X						F	F	F
				X	X	X	X	X	X	X	X	X	X				F	F	F
					X	X	X	X	X	X	X	X	X	X	X		F	F	F
						X	X	X	X	X	X	X	X	X	X	X	X	X	X
							X	X	X	X	X	X	X	X	X	X	X	X	X
								X	X	X	X	X	X	X	X	X	X	X	X
									X	X	X	X	X	X	X	X	X	X	X
										X	X	X	X	X	X	X	X	X	X
d ₁₉				X	F	F	F	F	F	F	F	X	X	X	X	X	X	X	X
d ₂₀				X	F	F	F	F	F	F	F	X	X	X	X	X	X	X	X

Fig. 7. (a) The nonzero pattern of Y (the nonzero elements of Y are marked X) and the fill-ins (marked F) introduced by the LU-decomposition.

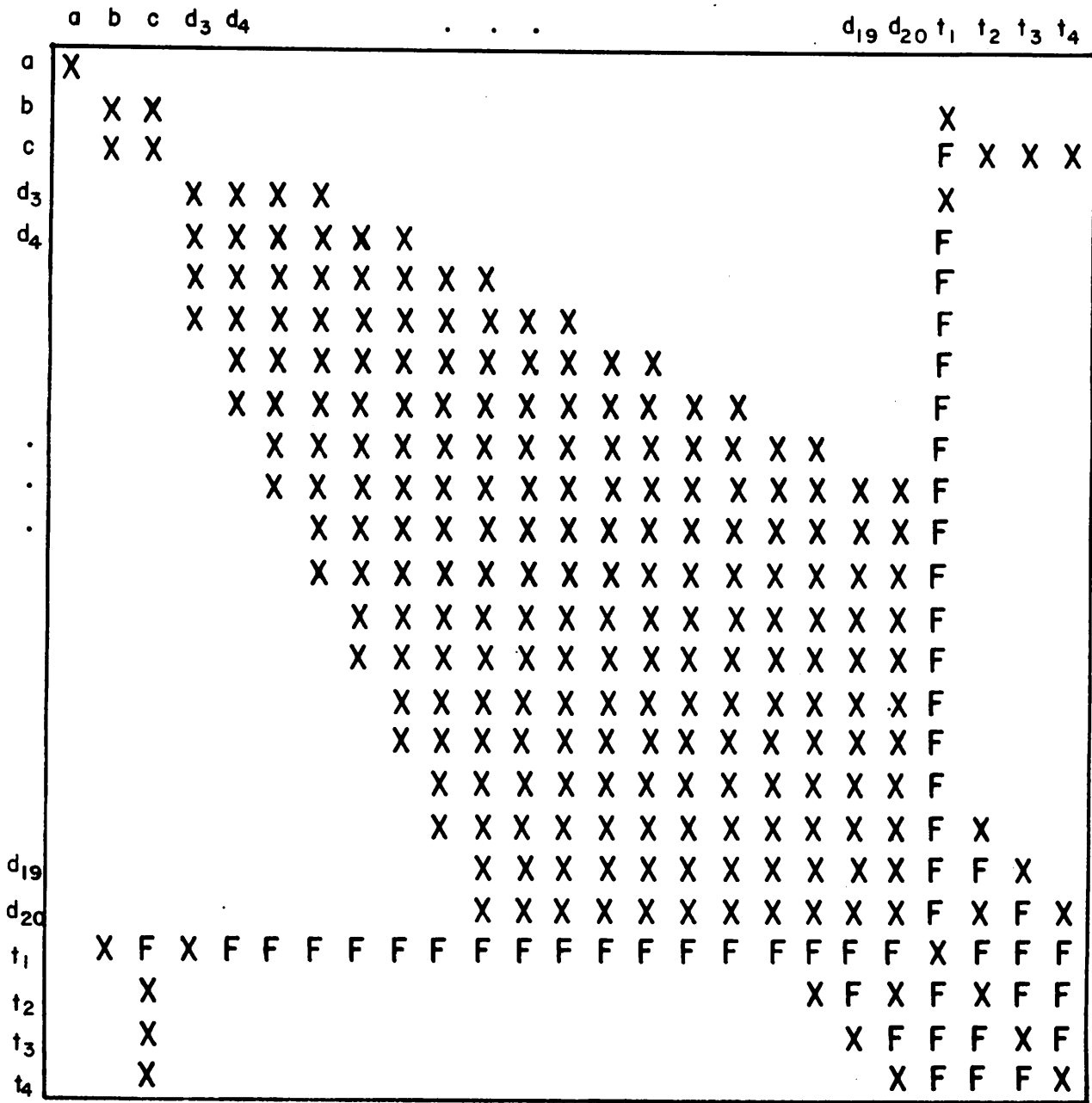

Fig. 7. (b) The nonzero pattern of T and the fi-l-ins introduced by the LU-decomposition.

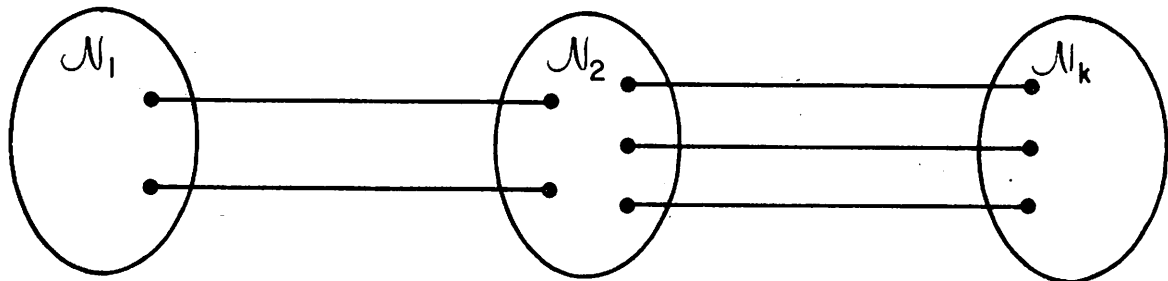

Fig. 8. Networks for which assumption (iv) of Fact 2 is satisfied.

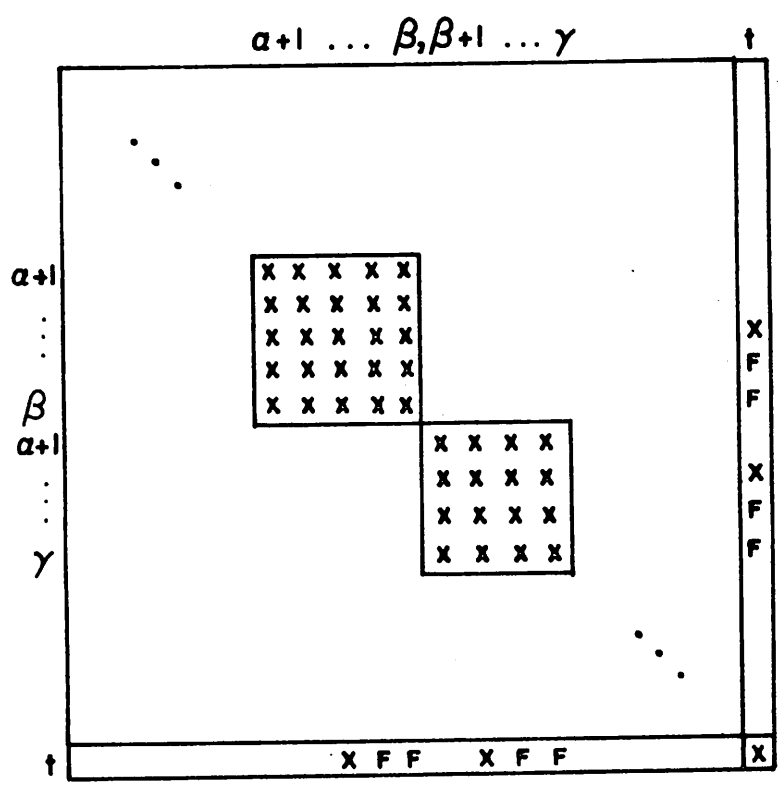
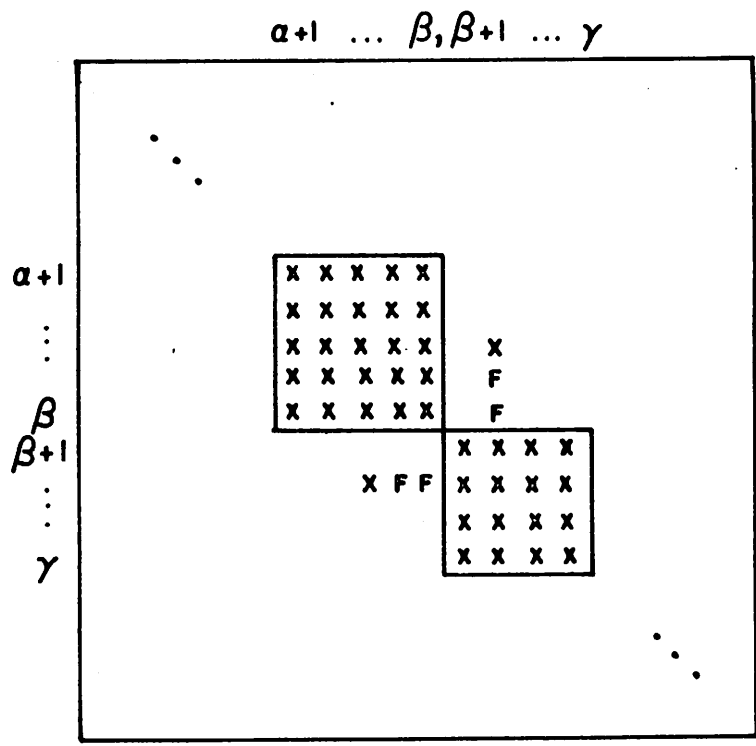

Fig. 9. (a) If the assumptions of Fact 2 are satisfied, fill-ins are restricted to the blocks between two adjacent diagonal blocks. (b) To each fill-in introduced in Y, there is a corresponding one in the same column of T.