

Copyright © 1978, by the author(s).  
All rights reserved.

Permission to make digital or hard copies of all or part of this work for personal or classroom use is granted without fee provided that copies are not made or distributed for profit or commercial advantage and that copies bear this notice and the full citation on the first page. To copy otherwise, to republish, to post on servers or to redistribute to lists, requires prior specific permission.

STABILITY OF MULTIDIMENSIONAL SCALAR AND MATRIX POLYNOMIALS

by

E. I. Jury

Memorandum No. UCB/ERL M78/7

23 January 1978

ELECTRONICS RESEARCH LABORATORY

College of Engineering  
University of California, Berkeley  
94720

## Outline of the Paper

- I. Introduction
- II. Brief Review of One-Dimensional Stability (Scalar Case)
- III. Stability of Two-Dimensional Polynomials (Scalar Case)
- IV. Stability of Multidimensional Polynomials (Scalar Case)
- V. Brief Review of One-Dimensional Stability (Matrix Case)
- VI. Stability of Two-Dimensional Polynomials (Matrix Case)
- VII. Stability of Multidimensional Polynomials (Matrix Case)
- VIII. Conclusions and Recommendation for Future Research
- IX. References

# STABILITY OF MULTIDIMENSIONAL SCALAR AND MATRIX POLYNOMIALS\*

E.I. Jury

Department of Electrical Engineering and Computer Sciences  
and the Electronics Research Laboratory  
University of California  
Berkeley, California 94720

## Summary

A comprehensive study of multidimensional stability and related problems of scalar and matrix polynomials is presented in this survey paper. In particular, applications of this study to stability of multidimensional recursive digital and continuous filters, to synthesis of network with commensurate and noncommensurate transmission lines, and to numerical stability of stiff differential equations are enumerated.

A novel approach to the multidimensional stability study is the classification of various regions of analyticity. Various computational tests for checking these regions are presented. These include the classical ones based on inners and symmetric matrix approach, table form, local positivity, Lyapunov test, the impulse response tests, the cepstral method and the graphical ones based on Nyquist-like tests. A thorough discussion and comparison of the computational complexities which arise in the various tests are included.

A critical view of the progress made during the last two decades on multidimensional stability is presented in the conclusions. The latter also includes some research topics for future investigations. An extensive list of references constitutes a major part of this survey.

---

\*Research sponsored by National Science Foundation Grant ENG76-21816.

## I. Introduction

In a recent survey paper [1], this writer had discussed in detail the stability and related problems of one-dimensional scalar polynomials. This study was mainly based on the inners concept. The contents of the present paper is a follow-up of the earlier one, and is devoted to stability of multidimensional scalar and matrix polynomials. It is hoped that the contents of these two papers will clarify and update the stability problem of linear dynamical systems first proposed by Maxwell [2] over a century ago.

During the last two decades, interest in the stability of two-dimensional polynomials arose in various applications. For instance stability of two-dimensional continuous filters arises in providing a test for a driving-point impedance realizability condition using commensurate-delay transmission lines and lumped reactances [3-5]. On the other hand, stability of two-dimensional digital filters occurs in the useful design of these filters. Such filters, in recent years, have found widespread applications in many fields, such as image processing, digitized photographic data and geophysics for processing of seismic, gravity and magnetic data. Other applications related to stability of two-dimensional polynomials arise in numerical stability of stiff differential equations [6-10]. A comprehensive study of stability of two-dimensional polynomials related to the above applications will be a major part of this survey.

Extension of the stability problem to multidimensional polynomials is receiving wide attention in recent years in view of the emerging widespread applications and hence these will be also discussed in this survey.

The mathematical basis of multidimensional stability and related problems lies in the theory of complex function of several variables. To this end a few references in this area are cited in this survey [11-21].

Such references serve as background material for the study of the problems discussed in this paper.

A survey of problems of two-dimensional stability of digital filters is discussed in [22] and for two and multidimensional stability appeared in [23]. Also collections of papers related to two-dimensional stability of digital filters appeared in [24].

In this paper similarities and differences between one dimensional and multidimensional stability definitions and tests will be emphasized and discussed. A significant and important difference lies in the fact that the singularities of  $F(z) = 0$  are isolated or distinct points and those of  $F(z_1, \dots, z_n) = 0$ , are multidimensional surfaces or manifolds. This fact makes the stability tests for multidimensional polynomials much more difficult. Other differences between general problems of one and multidimensional systems are discussed in detail in the survey paper by Bose [25].

Problems of stability related to one dimensional linear systems as surveyed in [1] were classified in terms of root-clustering in the complex plane. These included the open left half plane, the unit disc, the negative real axis and other related regions. The multidimensional stability and its related problems will be classified in this paper in terms of regions of analyticity. Such regions might encompass the hyperplane, the polydisc or several other regions. By using such a classification the stability conditions and the tests will be more organized and hopefully better understood.

A common feature of the one dimensional and multidimensional stability lies in their definition. In both cases the concept of bounded-input-bounded-output (BIBO) stability is used. This requires for the multidimensional recursive digital filter, for instance, that the sample response

$g(m,n,k,\dots)$  be absolutely summable, i.e.,

$$\sum_m \sum_n \sum_k \cdots \sum_\ell |g(m,n,k,\dots)| < \infty \quad (1)$$

Other forms of stability definitions will be also discussed in this survey. A minor difference between one dimensional and multidimensional stability lies in the definition of the z-transform. For the one dimensional case, the Z-transform is defined by

$$F(z) = \sum_{n=-\infty}^{\infty} f(n)z^{-n} \quad (2)$$

while for the multidimensional z-transform, it is generally defined in the literature of multidimensional digital filters as follows:

$$Z[\{f(n,m,k,\dots,\ell)\}] = \sum_{n=-\infty}^{\infty} \sum_{m=-\infty}^{\infty} \sum_{k=-\infty}^{\infty} \cdots \sum_{\ell=-\infty}^{\infty} f(n,m,k,\dots) z_1^n z_2^m z_3^k \cdots \quad (3)$$

This contrast in the definition is quite unfortunate for in some cases it causes some confusion. A remark as to conversion of the stability regions related to the classical definition of the z-transform as in (2) is commented on in [23].

The objectives of this paper are threefold. First, because of the increasing publication in this topic during the last twenty years, it appears that such a review is timely. This review would aid the investigator in this field to digest and evaluate the various definitions, tests and the computational problems. Secondly, by exposing the work done in this field, it becomes apparent what research problems need solution in order to advance these investigations. This is of importance in view of the many applications of the field of multidimensional systems. A recent issue

of this Proceedings [26] edited by Bose is devoted exclusively to the study of multidimensional systems. Thirdly, in reviewing and assessing the research done in this area, it appears that there are some errors in the definitions of the necessary and sufficient conditions for stability of two and multidimensional digital filters. Also some of the proofs seem to be incomplete or not quite correct. Hence, in this survey special attention is devoted to these and other critical problems which arise in multidimensional polynomials and which have no counterpart in the one dimensional case. Thus, it is hoped that the contents of this survey are both informative and correct so that the new researcher in this field feels confident in advancing the state of the field.

The structure of the paper is devoted to the following topics. In Section II, a brief review of the stability of one dimensional polynomials (scalar case) is given. In this review which supplements the earlier one [1], presents an important theorem related to the inners concept which could be of much use in the multidimensional case. As in the earlier review this supplement is devoted to the inners approach to the stability. In Section III, a complete study of the stability problems of two dimensional systems (scalar case) is presented. Most of the published material is devoted to this area, in view of the widespread applications and the availability of effective computational procedures. In this section the various stability tests are discussed in detail. These include the classical one based on the inner and symmetric matrix approach, table form, and local positivity. Also included in this section is the impulse response test, the cepstral method and the Nyquist-like test. In Section IV, the stability discussion is extended to multidimensional scalar polynomials. The regions of analyticity for the two-dimensional is generalized to the multidimensional



case. It is shown in this section that the computational efforts for the stability tests increase tremendously as the dimension increases. Also in this section the computational methods such as decision algebra, and algebraic geometry ideas, are discussed in detail and the efforts to simplify the tests are brought forth.

Having discussed the scalar case in detail, in Section V, the one dimensional polynomial matrix stability tests are briefly reviewed. This review will set the stage for the discussion of two dimensional matrix polynomials discussed in Section VI. The application of such a case lies in the stability of tests of two-dimensional multi-input multi-output linear digital filters. In addition to the Lyapunov test, the various tests developed in Section III are used for this case too. Extension of the stability discussion for multi-dimensional multi-input multi-output linear recursive digital filters is discussed in Section VII. The major difficulties encountered in this case as compared to the two-dimensional case are emphasized. Similar to the two-dimensional case, the methods used for testing stability for the multi-dimensional scalar case are readily applicable.

Finally in Section VIII a critical view of the material presented in this paper is discussed. In particular problems for future research are singled out for further investigations.

An extensive list of references is presented in Section IX. Such a list, though not very complete, serves as a starting point for the new researcher in this challenging and emerging field of investigations.

## II. Brief Review of One Dimensional Stability (Scalar Case)

In a previous survey paper [1], a review of the one dimensional stability of a scalar polynomial is presented in detail. In this review the theory of inners was presented and applied to many problems of stability and related topics. Since this publication, many papers on the inners have appeared [27-28] which clarified and extended the application of this notion. As will be explained in later sections, the theory of inners is also applicable to problems of multidimensional stability and hence the following theorem recently obtained [29] will shed some light on these applications. Also it would put the inners notion into more mathematical basis. Because of its importance, it will be stated in the following

Theorem 1 [29]. Let the square matrix T be given as:

$$T = \begin{array}{cc} & \begin{array}{c} m-1 \\ m \end{array} \\ \begin{array}{c} T_1 \\ \vdots \\ 0 \\ \vdots \\ T_3 \end{array} & \begin{array}{c} T_2 \\ \vdots \\ T_4 \end{array} \\ & \begin{array}{c} m-1 \\ m \end{array} \end{array} \quad (4)$$

where  $T_1$  is upper triangular<sup>†</sup> and  $T_3$  is lower skew triangular (or  $J_k T_3$  is upper triangular, where  $J_k$  is the matrix having ones on the second diagonal and zero elsewhere). Multiply the above matrix by another matrix as follows:

$$\begin{bmatrix} I_{m-1} & 0 \\ L & I_m \end{bmatrix} \begin{bmatrix} T_1 & T_2 \\ T_3 & T_4 \end{bmatrix} = \begin{bmatrix} T_1 & T_2 \\ 0 & \vdots & R \end{bmatrix} \begin{array}{c} m-1 \\ m \end{array} \quad (5)$$

with  $L = -T_3 T_1^{-1}$  (which always exists).

<sup>†</sup>Note that  $T_1$  has unit elements on the main diagonal and I is the identity matrix.

It follows that the inners determinants of  $T$  are identically the leading principal minors of  $R$  where  $R$  is about a half size matrix. Note we can transform  $R$  to be a symmetric matrix  $R_s$  by premultiplying the above equation by a suitable triangular matrix. With this in mind we state:

Corollary 1. When  $T$  is a "Sylvester type matrix", then the symmetric matrix  $R_s$  becomes the Hermite quadratic form (or the Bézoutian) associated with the two polynomials used to generate the Sylvester matrix. Thus, we have the following identity

$$\{T \text{ is P.I. (Positive Innerwise)}\} \Leftrightarrow R_s \text{ is P.D.S. (Positive Definite Symmetric)} \quad (6)$$

#### Remarks

1. The above identity was utilized in the survey paper [1] as well as in the inners text [23] to present the stability or root clustering problem in terms of either P.I. or P.D.S. matrices. This corollary will be also utilized in later sections for multidimensional stability tests.

2. Knowing  $R_s$  one cannot recover the unique  $T$  unless  $T_1$  and  $T_2$  are known. This is due to the fact that  $R_s$  was obtained from  $T$  using a certain algorithm. [29].

3. The left triangle of zeros of  $T$  is utilized effectively to obtain a recursive algorithm to calculate the inners determinants. This is also discussed in [1] and [23]. This algorithm can be also extended to compute the inners determinants associated with multidimensional stability and related problems.

4. Though the inners notion in [1] was exclusively used for testing stability of one dimensional polynomials, there exists several other methods which are not discussed in that paper. However, in the present paper all

the known methods for testing stability of one dimensional polynomials are applied to the multidimensional case. This represents a basic departure from the objectives of the earlier survey.

5. The corollary under restrictive conditions can be extended to the case when  $T$  is the generalized Sylvester matrix [29a]. The application of this will be discussed in Section V.

### III. Stability of Two-Dimensional Polynomials (Scalar Case)

Problems related to the stability of two dimensional scalar polynomials arise in many engineering applications. Historically, such applications were first introduced by Ansell [4] in connection with the testing of two-variable reactance properties with application to networks of transmission lines and lumped reactances. In recent years, considerable work has been devoted to the area of two-dimensional digital filters. Stability problems related to such filters are well established in the literature and hence we will study the stability of such filters first. Finally, in this section, we will also study stability problems related to numerical integration methods. Such methods include tests for A-stability,  $A(\alpha)$ -stability and stiff stability [10]. Also, in this section, we will apply the stability tests to the various regions of analyticity as related to the above three major applications.

#### A. Stability of Two-Dimensional Digital Filters

There are various recursive schemes applied to these filters. These include the quarter-plane, the symmetric half-plane and asymmetric half plane filters. Each of these filters give rise to different analyticity regions and hence these will be discussed separately.

##### a. Stability Property of Quarter-Plane Filters

The difference equation which describes the input-output relationship of such filters is presented as:

$$y(m,n) = \sum_{k=0}^K \sum_{\ell=0}^L p(k,\ell)x(m-k,n-\ell) - \sum_{\substack{i=0 \\ (i,j) \neq (0,0)}}^I \sum_{j=0}^J q(i,j)y(m-i,n-j) \quad (7)$$

In the above linear difference equation,  $\{x(m,n)\}$  and  $\{y(m,n)\}$  represent the input and output sequences respectively. Figure 1 shows how the above computation proceeds. First quadrant filters are often termed "causal" or "spatially causal". The latter definition is used by Strinzis.<sup>†</sup> A feature of such filters is related to the fact that the value of a given point,  $y(m,n)$ , of the sequence depends only on the values of those points,  $x(i,j)$ , of the input sequence for which both  $i \leq m$  and  $j \leq n$ . Recursive equations for the second, third and fourth quadrant filters are obtained similar to the above equation and discussed by Huang [30] and others [31]. Consequently, the first, second, third, and fourth quadrant filters are said to recurse in the ++, -+, --, and +- directions.

The two-dimensional z-transform of equation (7) leads to the transfer function,

$$G(z_1, z_2) = \frac{P(z_1, z_2)}{Q(z_1, z_2)} \quad (8)$$

where  $P(z_1, z_2)$  and  $Q(z_1, z_2)$  are the following two-dimensional polynomials in  $z_1$  and  $z_2$

$$\begin{aligned} P(z_1, z_2) &= \sum_{k=0}^K \sum_{\ell=0}^L p(k, \ell) z_1^k z_2^\ell \\ Q(z_1, z_2) &= \sum_{i=1}^I \sum_{j=0}^J q(i, j) z_1^i z_2^j \end{aligned} \quad (9)$$

In the first quadrant case, since  $q(0,0) = 1$  is assumed,  $Q(z_1, z_2) \neq 0$  in some neighborhood  $U_\epsilon^2 \triangleq \{(z_1, z_2) : |z_1| < \epsilon, |z_2| < \epsilon\}$  of  $(0,0)$ . Hence in  $U_\epsilon^2$  the function  $G(z_1, z_2)$  is analytic and has the power series expansion

$$G(z_1, z_2) = \sum_{m=0}^{\infty} \sum_{n=0}^{\infty} g(m, n) z_1^m z_2^n \quad (10)$$

<sup>†</sup>See references [44] and [64a].

$\{g(m,n)\}$  is the unit sample response of the first quadrant filter, and this filter is BIBO stable if and only if  $\{g(m,n)\}$  is absolutely summable, i.e.,

$$\sum_m \sum_n |g(m,n)| < \infty. \quad (11)$$

### Remarks

1. When equation (11) is satisfied we denote that  $\{g(m,n)\} \in \ell_1$ .

Also when  $\sum_m \sum_n |g(m,n)|^2 < \infty$ , we denote it as  $\{g(m,n)\} \in \ell_2$  and finally when  $|g(m,n)| < k$  for some  $k < \infty$  and for all  $(m,n)$  we denote it as  $\{g(m,n)\} \in \ell_\infty$ .

A discussion of these bounded forms will be mentioned later.

2. To apply the stability results for the other three quadrants, it is only necessary to note that  $G(z_1^{-1}, z_2)$ ,  $G(z_1^{-1}, z_2^{-1})$ , or  $G(z_1, z_2^{-1})$  can be realized as a stable first quadrant filter [30], provided no essential singularities of the second are introduced.

Consider now the two-dimensional rational function (in the literature these are also referred to as two variable rational functions) of equation (9), where  $P(z_1, z_2)$  and  $Q(z_1, z_2)$  are mutually prime (i.e., the two polynomials have no irreducible factors in common). A 2-tuple  $(z_1, z_2)$  such that  $Q(z_1, z_2) = 0$  but  $P(z_1, z_2) \neq 0$  will be called a pole or a nonessential singularity of the first kind (such a point is analogous to a pole in the one dimensional case). A 2-tuple  $(z_1, z_2)$  such that  $Q(z_1, z_2) = P(z_1, z_2) = 0$  will be called a nonessential singularity of the second kind (such points have no one dimensional analogs). Clearly, if  $(z_1, z_2)$  is a pole,  $G(z_1, z_2) = \infty$ . If  $(z_1, z_2)$  is a nonessential singularity of the second kind, the value of  $G(z_1, z_2)$  is undefined.

#### a.1 The effect of the numerator polynomial on stability. Perhaps,

potentially the most important stability theorem for two-dimensional filters is due to Shanks et al [32], who stated that  $G(z_1, z_2)$  is BIBO if and only if

$$Q(z_1, z_2) \neq 0 \text{ for all } \{(z_1, z_2): |z_1| \leq 1, |z_2| \leq 1\}. \quad (12)$$

Before applying this theorem, all irreducible factors common to  $P(z_1, z_2)$  and  $Q(z_1, z_2)$  should first be cancelled (mutually prime polynomials). A test for the existence of common factors is given in [33], and an algorithm for extraction of the greatest common factor is given in [34]. A similar theorem with some generalization for the case when  $P(z_1, z_2) = 1$  was given by Farmer and Bednar [35]. Shanks' theorem was used and quoted by many authors as the necessary and sufficient condition for stability. Recently in a classic paper by Goodman [36], it is shown that the necessity condition does not hold. This is due to the effect of the numerator on stability (which has no analog in the one dimensional case). The reason is as follows: In some cases  $G(z_1, z_2)$  has a nonessential singularity of the second kind on  $|z_1| = 1$  and  $|z_2| = 1$  but  $\{g(m, n)\} \in \ell_1$ . The following two examples illustrate this point:

$$G_1(z_1, z_2) \triangleq \frac{(1-z_1)^8 (1-z_2)^8}{2 - z_1 - z_2} \triangleq \frac{P_1(z_1, z_2)}{Q(z_1, z_2)} \quad (13)$$

$$G_2(z_1, z_2) \triangleq \frac{(1-z_1)(1-z_2)}{2 - z_1 - z_2} \triangleq \frac{P_2(z_1, z_2)}{Q(z_1, z_2)} \quad (14)$$

The above transfer functions have mutually prime numerator and denominator, and  $Q(z_1, z_2) \neq 0$  on  $\{(z_1, z_2): |z_1| \leq 1, |z_2| \leq 1\}$  except at  $z_1 = z_2 = 1$ . Both  $G_1(z_1, z_2)$  and  $G_2(z_1, z_2)$  have nonessential singularities of the second kind at  $z_1 = z_2 = 1$ , but as shown by Goodman [36],  $G_1(z_1, z_2)$  is BIBO stable and  $G_2(z_1, z_2)$  is BIBO unstable. Hence, Shanks theorem is only sufficient for BIBO stability.



### Remarks

1. For effective design of two-dimensional digital such cases presented above are to be avoided [25]. Hence, for consideration of design and avoiding such singularities, it is suggested privately by Saeks and Anderson, that the BIBO stability should be referred to as "structural stability".<sup>†</sup> A mention of such type of singularities was also indicated by Humes and Jury [37].

2. Critical cases involving non-essential singularities of the second kind as applied to multidimensional network synthesis were also noted in the work by Bose and Newcomb [38]. In the work of Goodman [36] several theorems are given which are repeated in this survey.

3. To test for the presence or absence of nonessential singularity of the second kind on the unit bidisc, it becomes necessary to ascertain whether or not at  $|z_{10}| = |z_{20}| = 1$ ,  $P(z_{10}, z_{20}) = Q(z_{10}, z_{20}) = 0$ . Though it is possible to solve this problem as implied by the results from elementary decision algebra [39], the computational complexity is excessive, especially for dimensions higher than two.

4. When  $G(z_1, z_2) = \frac{1}{Q(z_1, z_2)}$ , the stability theorem of Farmer and Bednar gives the necessary and sufficient conditions for BIBO stability.

In the following, we will present few theorems related to stability:

Theorem 2. If  $G(z_1, z_2)$  represents a BIBO stable filter, then  $G(z_1, z_2)$  has no poles in the analyticity region of equation (12), and no nonessential singularities of the second kind in that region, except possibly on the distinguished boundary of the unit bidisc (i.e.,  $\{(z_1, z_2): |z_1| = |z_2| = 1\}$ ). The above is a necessary condition for BIBO stability.

Theorem 3. If  $G(z_1, z_2)$  has a bounded unit sample response, then  $G(z_1, z_2)$  is analytic in  $\{(z_1, z_2): |z_1| \leq 1, |z_2| \leq 1\}$  or  $Q(z_1, z_2) \neq 0$  in the same region.

---

<sup>†</sup>See also [71].

Theorem 4. If  $G(z_1, z_2)$  is bounded in  $\{(z_1, z_2): |z_1| < 1, |z_2| < 1\}$ , then  $\{g(m, n)\}$  is square summable or belongs to  $\ell_2$ .

Theorem 5. If  $Q(z_1, 0) \neq 0$  in equation (8) for  $|z_1| \leq 1$ , then for any fixed  $n$ ,  $g(m, n) \rightarrow 0$  geometrically in  $n$  and

$$\sum_{m=0}^{\infty} |g(m, n)| < \infty \quad (15)$$

In summarizing the discussion of this subsection, we state the following for  $G(z_1, z_2)$  in equation (8) in a table form.

Table 1. Various stability definitions

- a. BIBO stability  $\Leftrightarrow \{g(m, n)\} \in \ell_1$
- b.  $Q(z_1, z_2) \neq 0$  in  $\{(z_1, z_2): |z_1| \leq 1, |z_2| \leq 1\} \xrightarrow{\nleftrightarrow}$  BIBO stability
- c.  $Q(z_1, z_2) \neq 0$  in  $\{(z_1, z_2): |z_1| \leq 1, |z_2| \leq 1\}$ , except at  $|z_1| = |z_2| = 1$   
 $\xrightarrow{\nleftrightarrow}$  BIBO stability
- d.  $\{g(m, n)\} \in \ell_2 \xrightarrow{\nleftrightarrow}$  BIBO stability
- e.  $\lim_{m, n \rightarrow \infty} \{g(m, n)\} = 0 \xrightarrow{\nleftrightarrow} \{g(m, n)\} \in \ell_1$  or  $\{g(m, n)\} \in \ell_2$
- f.  $Q(z_1, z_2) \neq 0$  in  $\{(z_1, z_2): |z_1| < 1, |z_2| < 1\} \xrightarrow{\nleftrightarrow} |g(m, n)| \leq M < \infty$ ,  
for all  $m, n$
- g.  $|G(z_1, z_2)| \leq N < \infty$  in  $\{|z_1| < 1, |z_2| < 1\} \longrightarrow \{g(m, n)\} \in \ell_2$
- h.  $Q(z_1, 0) \neq 0$  in  $\{|z_1| \leq 1, |z_2| \leq 1\} \longrightarrow \sum_{m=0}^{\infty} |g(m, n)| < \infty$ , for all  $n$ .

The above results have several important implications for the two-dimensional filter design problem. In this survey, we do not discuss this; however, we refer the reader to references [40] and [41].

a.2 Regions of analyticity for quarter plane filters. In the following discussion, we will assume that both  $P(z_1, z_2)$  and  $Q(z_1, z_2)$  in equation (8) are mutually prime. Furthermore, we also assume that neither has non-essential singularities of the second kind on the unit bidisc. Both of these cases are discussed earlier. Based on these assumptions, the stability condition is ascertained by checking for the following analyticity region as obtained by Shanks [32].

$$Q(z_1, z_2) \neq 0, \text{ for all } \{(z_1, z_2): |z_1| \leq 1, |z_2| \leq 1\} \quad (16)$$

To apply the above test, we have to map the region of the  $z_1$ -plane,  $|z_1| \leq 1$  into the  $z_2$ -plane by algebraic mapping  $Q(z_1, z_2) = 0$ . If the image of that map lies completely outside the circle  $|z_2| = 1$ , the filter is stable; otherwise, it is not. This test is computationally involved and does not lead to a finite algorithm. In a later work, Huang [30], based on the earlier work of Ansell [4] on the stability of two-dimensional Hurwitz polynomials, had simplified the above test considerably. This was done by showing that the above region is equivalent to the following region:

$$\begin{aligned} \text{i) } & Q(z_1, 0) \neq 0, \quad |z_1| \leq 1 \\ \text{ii) } & Q(z_1, z_2) \neq 0, \quad |z_1| = 1, \quad |z_2| \leq 1 \end{aligned} \quad (17)$$

Huang's proof of the equivalence of regions (16) and (17) is not complete and unfortunately his proof was propagated in some texts [23].

Recently, new and rigorous proofs were supplied by Goodman [42], Davis [43] and still another by Murray [43a]. Hence, it is established that Huang's theorem is correct.<sup>†</sup>

<sup>†</sup>A simple proof of Huang's theorem is contained in Gunning and Rossi, *Analytic functions of several complex variables*, Prentice-Hall, 1963, Ch. 1, Section C, Theorem 7. The author is grateful to John Murray for bringing this to his attention. Similar proofs appeared in Goodman [40] and Strinzis [44].

Remarks

1. The analyticity region in equation (17) is exchangeable as far as  $z_1$  and  $z_2$  are concerned. This exchangeable property is computationally useful in certain forms of two-dimensional polynomials.

2. The testing of region (17) can be performed by a finite algorithm which relies heavily on root clustering properties of one dimensional polynomials. Various forms of such an algorithm will be presented later in this section. Furthermore, the first condition of (17) can be also replaced by  $Q(z_1, a) \neq 0$ , for all  $|a| \leq 1$  and  $|z_1| \leq 1$  [44].

In independent works by Strintzis [44] and DeCarlo, Murray, and Saeks [45], it has been shown that another region of analyticity is equivalent to equation (17). This is given as follows:

$$\begin{aligned}
 \text{i)} \quad & Q(a, z_2) \neq 0, \text{ for some } a, |a| \leq 1, \text{ when } |z_2| \leq 1 \\
 \text{ii)} \quad & Q(z_1, b) \neq 0, \text{ for some } b, |b| = 1, \text{ when } |z_1| \leq 1 \\
 \text{iii)} \quad & Q(z_1, z_2) \neq 0, |z_1| = |z_2| = 1
 \end{aligned} \tag{18}$$

In particular, with the choice of  $a = b = 1$ , the above conditions become

$$\begin{aligned}
 Q(1, z_2) \neq 0, \quad & |z_2| \leq 1 \\
 Q(z_1, 1) \neq 0, \quad & |z_1| \leq 1 \\
 Q(z_1, z_2) \neq 0, \quad & |z_1| = |z_2| = 1
 \end{aligned} \tag{19}$$

Still another region of analyticity was developed by DeCarlo et al [45] and it is presented as follows:

$$\begin{aligned}
 Q(z_1, z_2) \neq 0 \text{ for } z_1 = z_2 = z, \text{ when } |z| \leq 1 \\
 Q(z_1, z_2) \neq 0 \text{ for } |z_1| = |z_2| = 1
 \end{aligned} \tag{20}^\dagger$$

---

<sup>†</sup>The first inequality follows directly from the first two conditions of equation (18).

Remarks

1. In contrast to the one-dimensional digital filter, the stability test for the two-dimensional case involves several regions of analyticity while the former has one region (i.e., root clustering outside the unit disc).

2. The significance of these various regions lies in the computational aspects for the various tests. This gives more degrees of freedom in ascertaining the most economical test. Again, as remarked earlier the algorithm for testing for the regions (17)-(20) is finite and relies on the well known stability tests for one-dimensional polynomials.

b. Stability Property of Asymmetric<sup>†</sup> Half-Plane Filters

Asymmetric half-plane filters (also referred to by Strinzis [29,44] as nonanticipative) are an extension of the quarter-plane filters and, in fact, quarter plane filters may be considered to be a special case of such filters.<sup>††</sup> As shown by Dudgeon [46], the asymmetric half-plane filter is the most general such filter, and, furthermore, has important theoretical advantages over the quarter-plane filters. In this survey which is devoted to stability problems, we will not discuss these advantages; however, the reader is referred to Dudgeon [46] and Goodman [40] for such discussions.

The difference equation of such filters is given by:

$$\begin{aligned}
 y(j,k) = & \sum_{n=0}^{N_a} a(0,n)x(j,k-n) + \sum_{m=1}^{M_a} \sum_{n=-L_a}^{N_a} a(m,n)x(j-m,k-n) \\
 & - \sum_{n=1}^{N_b} b(0,n)y(j,k-n) - \sum_{m=1}^{M_b} \sum_{n=-L_b}^{N_b} b(m,n)y(j-m,k-n)
 \end{aligned} \tag{21}$$

The weighting sequences  $\{a(m,n)\}$  and  $\{b(m,n)\}$  have support on a region whose shape is shown in Figure 2. There are seven other support regions whose recursion equations are similar to equation (21), but the orders of

<sup>†</sup>Sometimes referred to in the literature as nonsymmetric [47].

<sup>††</sup>Lévy, et al. [126] have shown that using coordinate transformation one can obtain the properties of half-plane filters from the quarter-plane.

computation of the output sequence are different. For detailed discussion of recursiveness as well as stability of all eight classes, the reader is referred to Ekstrom and Wood [47,47a] and Dudgeon [46]. In Figure 3, it is shown how the output sequence of a filter with difference equation (21) is computed. A given point,  $y(j,k)$ , of the output sequence can be computed if and only if all of the points under the output mask have been computed previously. Thus the possible orders of computation are more limited in the asymmetric half-plane case than in the quarter plane case. This ordering is reflected on the region of analyticity for stability properties of this filter. This is explained as follows:

The transfer function of the filter described by equation (21) is:

$$G(z_1, z_2) = \frac{P(z_1, z_2)}{Q(z_1, z_2)} \quad (22)$$

where

$$P(z_1, z_2) = \sum_{n=0}^{N_a} a(0, n) z_2^n + \sum_{m=1}^{M_a} \sum_{n=-L_a}^{N_a} a(m, n) z_1^m z_2^n \quad (23)$$

$$Q(z_1, z_2) = \sum_{n=0}^{N_b} b(0, n) z_2^n + \sum_{m=1}^{M_b} \sum_{n=-L_b}^{N_b} b(m, n) z_1^m z_2^n \quad (24)$$

Assuming the numerator and denominator or polynomials of equations (22) are mutually prime and neither has non-essential singularities of the second kind on  $|z_1| = |z_2| = 1$ , the stability condition as given by Ekstrom and Wood [47] is presented in the following region of analyticity:

$$\begin{aligned} Q(0, z_2) &\neq 0 \text{ for all } |z_2| \leq 1 \\ Q(z_1, z_2) &\neq 0 \text{ for all } |z_2| = 1, |z_1| \leq 1 \end{aligned} \quad (25)$$

It should be emphasized that although equation (25) has similar but not the same form as equation (17), the roles of  $z_1$  and  $z_2$  are not interchangeable as in the quarter plane case. Hence we consider equation (25) as a different region.

### Remarks

1. One can also obtain similar regions of analyticity as in (18) and (20) for the asymmetric half-plane filters.
2. The effect of the numerator on stability follows exactly as in the first quarter plane.
3. If  $G(z_1, z_2) = 1/Q(z_1, z_2)$ , then  $G(z_1, z_2)$  is a stable transfer function if and only if  $Q(z_1, z_2) \neq 0$ , for all  $\{(z_1, z_2): |z_1| \leq 1, |z_2| \leq 1\}$ .

### c. Stability Property of Symmetric Half-Plane Filters

Stability of symmetric half-plane filters, also referred to by Strinzis [48] as spatially non-causal filters, were first discussed by Shanks and Justice [32], who gave the following region of analyticity as a stability test of  $G(z_1, z_2) = \frac{1}{Q(z_1, z_2)}$ :

$$Q(z_1, z_2) \neq 0 \text{ when } |z_2| = 1, |z_1| \leq 1 \quad (26)$$

Using Strinzis [44] or DeCarlo et al [45] results, the above is simplified to give

$$Q(z_1, b) \neq 0 \text{ for some } |b| = 1, \text{ when } |z_1| \leq 1$$

and

$$Q(z_1, z_2) \neq 0 \text{ when } |z_1| = |z_2| = 1 \quad (27)$$

In equation (26),  $Q(z_1, z_2)$  is given by

$$Q(z_1, z_2) = 1 + \sum_{m=0}^N \sum_{n=-N}^N a_{mn} z_1^n z_2^m \quad (28)$$

A modification of the above symmetric filter  $1/Q(z_1, z_2)$  which is recursive is given by Murray [49] as follows:

$$Q(z_1, z_2) = 1 + \sum_{m=1}^M \sum_{n=-N}^N a_{mn} z_1^n z_2^m \quad (29)$$

The above filter omits all of the row  $m = 0$  except for the constant term. It differs from the asymmetric half-plane filter in the fact that the latter omits half of this row.

The filter is stable if and only if the following region of analyticity is satisfied:

$$Q(z_1, z_2) \neq 0, \quad |z_1| = 1 \text{ and } |z_2| \leq 1. \quad (30)$$

The above is the same as equation (26). The advantage of such a filter lies in the fact that it is recursively realizable, while that of Shanks and Justice is not.

Another form of noncausal two-dimensional linear filter (or processor) is presented by S.S.L. Chang [50]. Such processors are said to be stable if their impulse response decreases exponentially in all four directions. In this work Chang [50] proved the following theorem:

Theorem 6. Let  $P$  and  $Q$  denote polynomials in  $z_1$  and  $z_2$  such that the following region of analyticity is satisfied:

$$Q(z_1, z_2) \neq 0 \text{ for all } |z_1| = |z_2| = 1 \quad (31)$$

Then the rational function

$$G(z_1, z_2) \triangleq \frac{P(z_1, z_2)}{Q(z_1, z_2)} \quad (32)$$

has a unique stable expansion.



Note in this case the z-transform of the two-dimensional input is defined as

$$X(z_1, z_2) = \sum_{m=-\infty}^{\infty} \sum_{n=-\infty}^{\infty} x(n, m) z_1^{-m} z_2^{-n} \quad (33)$$

Similarly the z-transform of the output and impulse sequence is so defined. This indicates the non-causality but the recursiveness of the filter. Also note that the definition of stability in this case is different from the earlier presented form. In concluding this discussion on recursive filters, it might be mentioned that the class of finite impulse response (FIR) or nonrecursiveness, the problem of instability does not arise, for in such cases the filter is always stable.

#### B. Stability of Two-Dimensional Continuous Filters

The first work related to stability of two-dimensional continuous filters is probably due to Ansell [4]. In this work, the author was concerned with obtaining a test for the two-variable reactance property. Such a test has an application to networks of commensurate delay transmission lines and lumped reactances. In the process of obtaining such a test, Ansell introduced the following definition:

Definition. A real polynomial in  $s_1$  and  $s_2$ ,  $G(s_1, s_2)$ , is a two variable Hurwitz polynomial in the narrow sense if it has the following property:

$$\begin{aligned} &G(s_1, s_2) \neq 0, \operatorname{Re} s_1 > 0, \operatorname{Re} s_2 > 0 \\ \text{and} \quad &G(s_1, s_2) \neq 0, \operatorname{Re} s_1 > 0, \operatorname{Re} s_2 = 0 \\ &G(s_1, s_2) \neq 0, \operatorname{Re} s_2 > 0, \operatorname{Re} s_1 = 0 \end{aligned} \quad (34)$$

Remarks

1. The definition of Hurwitz in the narrow sense is generalized from the one-dimensional real polynomial, in which case it is defined as

$$G(s) \neq 0, \quad \text{Re } s \geq 0 \quad (35)$$

The above definition is introduced to distinguish it from polynomials of the property:

$$G(s) \neq 0, \quad \text{Re } s > 0 \quad (36)$$

2. Ansell's definition of two-variable Hurwitz polynomials in the narrow sense is unfortunate. To be consistent with the one-dimensional case, the following definition is adopted:

$$G(s_1, s_2) \neq 0, \quad \text{Re } s_1 \geq 0, \quad \text{Re } s_2 \geq 0 \quad (37)$$

Similar to the discrete case, it is conjectured that the above condition guarantees that the impulse response of  $1/G(s_1, s_2)$  is in  $L_1$ . Thus we have "BIBO" stability. However, a proof is still lacking. In the following discussion we will refer to polynomials satisfying the analyticity region (37) as "Two-Dimensional Hurwitzian".

Based on the maximum modulus theorem, Ansell simplified the analyticity region of (34) to the following:

- i)  $G(s_1, 1) \neq 0, \quad \text{Re } s_1 \geq 0$
- ii)  $G(j\omega, s_2) \neq 0, \quad \text{Re } s_2 > 0, \quad \text{for all } \omega$
- iii)  $G(s_1, s_2)$  has no factor  $(s_1 - s_{20})$  having  $\text{Re } s_{20} = 0$

There exists a finite algorithm to test for the above region, which will be discussed in part D of this section.

In obtaining a finite algorithm for the stability test of first quarter two-dimensional digital filters, Huang [30] modified the above equation

(without proof) to give the stability test for the region in (37) as follows:

$$\begin{aligned} \text{i) } & G(s_1, 1) \neq 0, \operatorname{Re} s_1 \geq 0 \\ \text{ii) } & G(j\omega, s_2) \neq 0, \operatorname{Re} s_2 \geq 0, \text{ for all } \omega \end{aligned} \quad (39)$$

Using a bilinear transformation<sup>†</sup> the above region is the Huang's stability region of equation (17). This justifies the definition of "Two-Dimensional Hurwitzian" introduced in the above remark. The algorithms to be used to check for (39) will be introduced later on. A proof for obtaining the equivalence of (37) and (39) can be constructed on similar lines as for the discrete analog. An analog continuous region, similar to (19), has been obtained by Strinzis [44]. Also some necessary conditions for the stability of  $G(s_1, s_2)$  are given by Weinberg [5].

### C. Stability Properties for Numerical Integration Methods

Arithmetic tests for A-stability,  $A(\alpha)$ -stability and stiff stability are special cases of general stability tests for numerical integration methods [6-10,51]. They are accepted as appropriate properties of numerical methods suitable for solving a stiff initial value problem, as described by a first order vector ordinary differential equation

$$\dot{\underline{x}}(t) = \underline{f}[\underline{x}(t), t] \quad (40)$$

with initial condition

$$\underline{x}(t_0) = \underline{x}_0 \quad (41)$$

The archtypical initial value problem by which the foregoing stability properties are given definition is that in which (40) is the scalar, linear equation

$$\dot{x}(t) = qx(t) \quad (42)$$

<sup>†</sup>Such a transformation should be used with caution because the regions are not always preserved. See Goodman, "Some difficulties with the double bilinear transformation in 2-D digital filter design," to be published in Proc. IEEE.

subject to the constraint  $\text{Re}\{q\} < 0$  and with initial condition  $x_0$ . Our concern is with those methods, defining with (42) a linear difference equation for  $x_n$  ( $n = 0, 1, 2, \dots$ ) -- a unique approximation of  $x(t)$  at  $t_n = nh + t_0$  ( $n = 0, 1, 2, \dots$ ) -- and having a real characteristic polynomial  $P$  in two variables (dimensions)  $\lambda (= hq)$  and  $\zeta$ , such that  $\{x_n\}$  is asymptotic to the origin if and only if  $P(\lambda, \zeta) = 0$  implies  $|\zeta| < 1$ . Under the precondition  $\text{Re}\{q\} < 0$ , the solution to the archtypical initial value problem is also asymptotic to the origin. The following discussion follows the work of Bickart and Jury [10].

### G.1 Stability Region

Let  $\mathcal{T}$  denote a simply connected open region of the extended complex plane  $C^*$  such that  $\partial\mathcal{T}$  -- the boundary of  $\mathcal{T}$  -- is piecewise regular. Then, a method is said to be stable with respect to if

$$P(\lambda, \zeta) \neq 0, \text{ for all } \lambda \in \mathcal{T} \text{ and } \zeta \in D^c \quad (43)$$

where  $D$  denotes the open unit disc, and  $D^c$  is the complement in  $C^*$ .

The above equation can also be written

$$P(\lambda, \zeta) \neq 0, \text{ for all } \lambda \in \mathcal{T} \text{ and } |\zeta| \geq 1 \quad (44)$$

### Remarks

Equation (44) differs from the regions of (16) and (37) in the fact that  $\zeta$  is related to the unit disc and  $\lambda$  to the left half plane (as will be seen later) and hence it is of mixed form. This represents a generalization of the regions discussed earlier in (A) and (B).

To obtain a convenient test to validate equation (44), we transform the polynomial  $P(\lambda, \zeta)$  into another polynomial  $Q(\lambda, s)$  as follows:

$$Q(\lambda, s) = (s-1)^{m_p} P(\lambda, \frac{s+1}{s-1}) \quad (45)$$

where  $m_p$  denotes the degree of  $P$  in  $\zeta$ . Correspondingly, we let  $m_q$  denote the degree of  $Q$  in  $s$ . Then we have the following theorem:

Theorem 7. The implication of (44) is valid if and only if  $m_q = m_p$  and

$$Q(\lambda, s) \neq 0, \text{ for all } \lambda \in \mathcal{T} \text{ and } \operatorname{Re} s \geq 0 \quad (46)$$

Similar to equations (16) and (34), the testing of (46) is very complicated even for the simplest forms of the region  $\mathcal{T}$ . Hence, in order to obtain a finite algorithm for testing stability, we can show as done earlier in (A) and (B) that the region of (46) is equivalent to the following region:

$$\begin{aligned} \text{i)} & \quad Q(\lambda, s_0) \neq 0, \text{ for all } \lambda \in \mathcal{T} \text{ and } s_0 \in \mathcal{L}^c \\ \text{ii)} & \quad \{\lambda \in \partial\mathcal{T} \cap \{\lambda: Q(\lambda, \cdot) \not\equiv 0\}\} \wedge \{s \in \bar{\mathcal{L}}^c\} \Rightarrow Q(\lambda, s) \neq 0 \end{aligned} \quad (47)$$

and

$$\text{iii)} \quad Q(\cdot, s) \not\equiv 0, \text{ for all } \operatorname{Re} s = 0$$

where  $\bar{\mathcal{L}}^c$  is the complement of the closure set of the open left half plane and  $\wedge$  means "and".

The tests of (47) are a root-clustering tests of (possibly, parametrized) one-dimensional polynomials and hence can be tested by a finite algorithm. Such tests will be discussed in part D. Furthermore, this test is more complicated than (17) and (38) because of the complexity of the region in equation (46).

## C.2 Special Cases

1. A-stability: In this case  $\mathcal{T}$  in equation (47) is the open left half plane (the Hurwitz region). Hence,  $\lambda \in \mathcal{T}$  becomes  $s_1 \in \mathcal{L}$  and  $s$  can be treated as the second dimension  $s_2$ .

2.  $A[\alpha]$ -stability: In this case for  $\alpha \in (0, \pi/2]$ , set  $\mathcal{J} = \mathcal{W}_\alpha = \{\lambda: |\arg\{-\lambda\}| < \alpha\}$ . The region  $\mathcal{W}_\alpha$  is presented in Figure 4.

3. Stiff stability: In this case the region  $\mathcal{J}$  is such that it contains the open half-plane  $\{\lambda: \operatorname{Re}\{\lambda\} < -\delta\}$  for some  $\delta \geq 0$  and has the origin as a boundary point. This is shown in Figure 5.

#### D. Stability Tests for Various Analyticity Regions

Having delineated the various stability regions in (A-C), in this part we will be mainly concerned with the various tests which have been known for the stability tests of two-dimensional scalar polynomials. Also, in this part we will indicate how to apply the various tests to the most important stability regions discussed earlier. The importance of the various finite tests lies in the computational properties of the operations involved.

##### a. Symmetric Matrix Forms [52]

It is known that stability tests for one-dimensional continuous and discrete scalar polynomials are checked by requiring a certain Hermitian matrix (Hermite matrix for the continuous case and Schur-Cohn matrix for the discrete case) to be positive definite. This matrix is formed under a certain rule from the coefficients of the polynomials under study. Such tests are well known and in reference [23] a complete study of these matrices is given.

To apply this form of matrix to the region of (17) we proceed following the work of Anderson-Jury [52] as follows:

1. From the first inequality of equation (17) we form the reciprocal polynomial of  $Q(z_1, 0)$  to obtain  $Q_1(z_1, 0) = z_1^n Q(z_1^{-1}, 0)$  where "n" is the degree of the one-dimensional polynomial in  $z_1$ . By so doing, the region

becomes  $|z_1| \geq 1$ , and hence we can use the symmetric matrix of the reduced Schur-Cohn as developed by Anderson-Jury [23], in this case.

To verify the first inequality of (17), the reduced Schur-Cohn matrix applied to the real polynomial  $Q_1(z_1, 0)$  ought to be positive definite or (P.D.) plus the positivity of about  $n/2$  of the bilinearly transformed coefficients [1]. We may note that if  $Q(z_1, 0)$  is used, then the reduced Schur-Cohn matrix is negative definite.

2. To check the second inequality of (17), we replace the polynomial  $Q(z_1, z_2)$ , considered as a polynomial in  $z_2$ , by its reciprocal (i.e.,  $Q_1(z_1, z_2)$ ) in a way similar to  $Q(z_1, 0)$ . By doing so,  $Q_1(z_1, z_2)$  is considered as a polynomial in  $z_2$ , whose coefficients are functions of a parameter  $z_1$ . For stability we require that the Schur-Cohn matrix for complex coefficients be positive definite (P.D.). In this case the entries of the Schur-Cohn matrix are polynomials in  $z_1$  and/or  $\bar{z}_1$  (conjugate). The minors of this matrix are again polynomials in  $z_1$  and  $\bar{z}_1$ , and are real because the Schur-Cohn matrix is Hermitian. This fact will be utilized for the checking of positive definiteness.

3. In a discussion by Šiljak [53], it is pointed out that for the Schur-Cohn Hermitian matrix to be (P.D.), it is required that only the determinant of the matrix be positive plus the auxiliary condition in which the Schur matrix for a point on the unit circle be positive. Usually, the point can be taken as  $z_1 = 1$ .

4. To check the positiveness of the Schur-Cohn determinant for  $|z_1| = 1$  and bearing in mind that on  $|z_1| = |e^{j\theta}| = 1$  we have  $\bar{z}_1 = e^{-j\theta} = z_1^{-1}$ , we obtain a polynomial of the following form:

$$f(z_1, z_1^{-1}) = \sum_{j=0}^N c_j (z_1^j + z_1^{-j}) \quad (48)$$

The above equation has to be positive (or of constant sign) on  $|z_1| = 1$ ,  
 To ascertain the above condition, we form the following polynomials:

$$g(z_1) = z_1^N f(z_1, z_1^{-1}) > 0 \quad \text{for } |z_1| = 1 \quad (50)$$

To satisfy equation (50), we require that

$$g(1) > 0 \quad (51)$$

and  $g(z_1)$  of degree  $2N$  has no roots on the unit circle or equivalently should have  $N$  roots inside the unit circle; since  $g(z_1)$  is a reciprocal polynomial, the other  $N$  are outside the unit circle. Tests for such conditions are well known in the literature [23,53].

Another method for testing equation (48) for positivity is to make the substitution (see reference [63] for this substitution):

$$x_1 = \frac{z_1 + z_1^{-1}}{2}, \quad (z_1^2 + z_1^{-2}) = 4x_1^2 - 2, \quad \dots \quad (52)$$

in equation (48), which implies that

$$-1 \leq x_1 \leq 1, \quad \text{when } |z_1| = 1 \quad (53)$$

Hence to check the positivity of equation (48), we require that  $f_1(x_1)$  be positive for all  $-1 \leq x_1 \leq 1$ , or alternatively  $f_1(x_1)$  be devoid of real zeros in this interval. Again, various tests [54] are available for checking this. The implication of this substitution will be considered when the Bose method [55] of local positivity test is discussed.

In order to discuss the testing of the other regions mentioned in part (A), we will make the following observation on the auxiliary condition mentioned earlier. If we denote the determinant of the Hermitian Schur-Cohn matrix as  $|\Delta|$ , then the auxiliary constraint can be written as:



$$|\Delta|_{\text{at } z_1=1} > 0 \quad (54)$$

The implication of (54) is that all the leading principal minors which are now determinants of matrices having constant coefficients are positive. This means that the polynomial  $Q_1(z_1, z_2) \Big|_{z_1=1}$  has all its roots inside the unit disc in the  $z_2$ -plane or alternatively the polynomial

$$Q(1, z_2) \neq 0, \quad |z_2| \leq 1 \quad (55)$$

The above is evident because the checking of (55) requires the positivity of the symmetric Schur-Cohn matrix related to  $Q(1, z_2)$  which is exactly the  $|\Delta|_{\text{at } z_1=1}$  in equation (54).

As pointed out in remark (2) of (a.2), the first condition of equation (17) can be also replaced (without affecting the stability region of (16)) with

$$Q(z_1, 1) \neq 0, \quad |z_1| \leq 1 \quad (56)$$

Comparing equations (55) and (56) with the first two equations of region (19) we arrive at the conclusion that the testing of the third condition of (19) is equivalent to testing the positivity of the determinant of the Schur-Cohn Hermitian matrix. Hence, from a computational point of view the testing of regions (17) and (19) is equivalent.

Similarly the testing of region (20) is now straightforward. The first condition is a one-dimensional real polynomial to be tested for stability. The second condition is similar to the third condition of (19).

The testing of the region of (25) is similar to (17), except in this case the roles of  $z_1$  and  $z_2$  are not interchangeable. The testing of the region (26) is again similar to testing the third inequality of (17). Finally, the testing of the region (31) is similar to testing of the last inequality

in (19).<sup>†</sup> Hence, in conclusion we have shown that the checking of all the analyticity regions in part (A) is performed by using the symmetric matrix form.

The application of the symmetric matrix approach to testing the regions in part (B) namely regions (38) and (39) can be performed in a similar fashion as for the regions in part (A).

Considering the region (39) first, we readily ascertain that the checking of (i) is readily performed using the symmetric form of the Liènard-Chipart method [23] of the one-dimensional real polynomial. To check (ii) we use the Hermitian matrix for the complex polynomial which requires [53] that its determinant be positive for all  $\omega$  and the matrix at  $\omega = 0$  be positive. The requirement that the determinant be positive is equivalent to the following even polynomial:

$$F(\omega^2) \geq 0, \quad \text{for all } \omega \geq 0 \quad (57)$$

The checking of equation (57) requires that the even polynomial  $F(\omega^2) = F(x)$  be devoid of positive real zeros. Such tests are available in the literature [23,53]. It may be remarked that (using bilinear transformation) Huang [30] applied this modified form of Ansell's results [4] to check the stability of (17).

The checking of the region (38) is more complicated. In this case the testing of the second condition requires that all the principal minors of the Hermitian matrix be non-negative (i.e.

$$|\Delta_i(\omega)| \geq 0, \quad \text{for all } \omega \text{ and } i = 1, 2, \dots, n \quad (58)$$

---

<sup>†</sup>We may note that the determinant of the Schur-Cohn Hermitian matrix is, except for a sign change, the same as the resultant of  $Q(z_1, z_2)$  written as a polynomial in  $z_2$  and its reciprocal (inverse) polynomial. A sufficient condition for satisfying the region (31) is that the resultant have no roots on the unit circle in the  $z_2$ -plane for all  $|z_1| = 1$ .

where  $n$  is the degree of  $G(j\omega, s_2)$  as a polynomial in  $s_2$ . The testing of (58) requires that  $n$  sets of the even polynomials corresponding to the  $n$  minors of the Hermitian matrix be devoid of odd numbers of positive real zeros. Again various tests are available [23,53] for checking this requirement.

In extending the application of the symmetric matrix form to the regions in part (C), one may note that if  $s_0$  is taken as real and equals unity in (i) of (47), we obtain a similar form of the first inequality of (38) or (39). Furthermore, ascertaining (ii) and (iii) for the special cases discussed in C.2 requires in part the checking of nonnegativity of the following even polynomials in certain regions (i.e.

$$|\Delta_i(\mu)| \geq 0, \quad \text{for all } \mu \in \mathcal{G} \text{ and } i = 1, 2, \dots, n \quad (59)$$

is required) where " $\mathcal{G}$ " represents a certain region and  $n$  is the number of the various polynomials. For a complete discussion of checking the stability regions of  $A$ ,  $A[\alpha]$  and stiff stability the reader is referred to Bickart and Jury [10].

b. Innerwise Matrix Form [1,23]

In section II of this review, we established in equation (6) that for each positive definite symmetric matrix there corresponds a positive innerwise matrix of double dimension. Hence, for the symmetric matrix form discussed in Corollary 1, there corresponds an innerwise matrix with about double dimension, but with left triangle of zeros. The pattern of the innerwise matrix makes it computationally attractive, for there exists a recursive algorithm for computing the inners determinants consecutively.

To explain briefly the inners approach to the stability of two-dimensional digital filters, we concentrate first on region (17) which can be rewritten as:

$$\begin{aligned}
\text{i)} \quad & Q_1(z_1, 0) \neq 0, \quad |z_1| \geq 1 \\
\text{ii)} \quad & Q_1(z_1, z_2) \neq 0, \quad |z_1| = 1, \quad |z_2| \geq 1
\end{aligned} \tag{60}$$

where  $Q_1$  is the reciprocal polynomial of  $Q(z_1, 0)$  in equation (17). To check condition (i) of equation (60), we require that  $(n-1) \times (n-1)$  innerwise matrix be positive innerwise (or P.I.) plus about  $n/2$  bilinearly transformed coefficients of  $Q$  to be positive. Such a test was discussed in an earlier survey paper [1] and in the text [23].

To check (ii) we require that the  $2n \times 2n$  Schur-Cohn matrix be written in an innerwise form [23], to be positive innerwise or (P.I.). The entries of this matrix are no longer constants as in real or complex polynomials but are functions of  $z_1$  such that  $|z_1| = 1$ . The condition of stability requires that this matrix be (P.I.), which is equivalent to the Schur-Cohn Hermitian matrix discussed in (a) being positive definite (P.D.). Hence, we call the Schur-Cohn innerwise matrix "innerwise Hermitian" because all the inner determinants (which are equivalent to the leading principal minor of the Schur-Cohn Hermitian matrix) are real. The checking of (ii) requires that the reciprocal polynomial obtained from the innerwise matrix determinant be positive plus an auxiliary constraint which requires that this matrix be positive for  $z_1 = 1$ . The last condition is equivalent (based on earlier discussions) to

$$Q_1(1, z_2) \neq 0, \quad \text{for all } |z_2| \geq 1 \tag{61}$$

The condition that the innerwise determinant be positive follows the same lines as in (a), namely the recursive polynomial should be devoid of zeros on the unit circle and be positive for one point on the unit circle. The checking of this special root distribution is discussed in detail in [1,23]. Similarly, we can check for all the regions discussed in (a).

In a similar fashion we can check equation (39) for stability for two-dimensional continuous filters as follows:

For condition (i) of (39), we use the Liènard-Chipart approach in an innerwise form. In this case the  $(n-1) \times (n-1)$  innerwise matrix is positive innerwise plus about  $n/2$  of the coefficients be positive.

In the checking of (ii) of equation (39) we form the  $n \times n$  innerwise matrix [1,23] whose entries are functions of  $\omega$ . This matrix is also "innerwise Hermitian" and hence we apply the same procedure as done in case (a) for the symmetric matrix form. In a similar fashion we can check for all the regions of parts A, B and C of this section. Furthermore, the polynomials in equation (59) are obtained from the inners determinants [10] rather than from the principal minors of the Hermitian matrices.

#### Remarks

1. The use of the computational algorithm based on the double triangularization of the innerwise matrix can be also extended for the stability of the two-dimensional polynomials.

2. In recent years, Bose and his coworkers [54-58] have extensively used the inners approach for checking the stability of two- and multidimensional digital and continuous systems. They have developed a computer program for computing exactly the inners determinants.

#### c. Table Form for Stability Check

It is well known that the Routh table which was developed a century ago can be adopted for checking the root-clustering and root-distributions of a one-dimensional polynomial with respect to the imaginary axis in the  $s$ -plane. Extension of the use of the Routh table to determining stability of two-dimensional continuous filters has been performed by Šiljak [53].

In his studies, Šiljak applied twice the Routh table to check stability: once for the real polynomial related to the first condition of (39) and the other time to the even polynomial which arises from testing the second condition of region (39). The connection between the table form and the inner-wise matrix approach is discussed by Jury [59] in the Routh Centennial Lecture.

A similar table form exists for the stability or for the root-distribution of real or complex polynomials with respect to its unit circle. Such a table form was discussed by Cohn [60], Marden [61], Jury [62] and others. The first authors to apply this table form to check the region of (17) were Maria and Fahmy [63]. In their work, the authors didn't utilize the simplification due to checking the positivity of the Schur-Cohn Hermitian matrix. Thus, Šiljak [53] in a later work has carried out this simplification, similar to the continuous case.

#### Remarks

1. In the work of Šiljak, the Routh table or its discrete analog was applied twice for checking regions (17) and (39). However, he computed both the Schur-Cohn Hermitian matrix and this matrix at a certain point, i.e. at  $z_1 = 1$  using the formulas for the symmetric matrix. It is evident that both of these can be separately computed using the table form.<sup>†</sup> Hence, the complete use of the table of checking the stability of two-dimensional digital filters requires its use four times. Similar conclusions can be reached for testing equation (19).

2. If we use region (20) for checking stability, we require only three times the use of the table. Thus, it appears that region (20) offers certain computational advantages in certain cases.

3. Though the table form has been discussed for the typical regions (17) and (39), it can be readily adopted to test for all other regions of analyticity discussed in parts A, B and C.

---

<sup>†</sup>Also, together they can be computed using one table.

d. Local Positivity Method

This method which was introduced by Bose [55] is based on some properties of network theory in one-dimensional continuous and discrete systems. The basic test for checking the second condition of region (17) using this method is based on the following theorem:

Theorem 8.  $Q_1(z_1, z_2) \neq 0$  for  $|z_1| = 1$ ,  $|z_2| \geq 1$  if and only if:

- 1) the zeros of  $D_1(0, z_2)$  and  $D_2(0, z_2)^\dagger$  are located on the unit circle  $|z_2| = 1$ ;
- 2) the zeros of  $D_1(0, z_2)$  and  $D_2(0, z_2)$  are simple and alternate on the unit circle  $|z_2| = 1$ ; and
- 3) the resultant  $R(x)$  of  $D_1(x, z_2)$  and  $D_2(x, z_2)$  has no real roots in the interval  $-1 \leq x \leq 1$ . (The polynomials  $R(x)$  or  $R(-x)$  have to be tested for positivity for the local region  $-1 \leq x \leq 1$ . Hence, the method is called "local positivity.")

To clarify the terms in the above theorems, we note

$$Q_1(z_1, z_2) = z_2^{n_2} Q(z_1, z_2^{-1}) \quad (62)$$

where  $n_2$  is the degree of  $z_2$  in  $Q(z_1, z_2)$ .

Let

$$Q_1(z_1, z_2) = \sum_{k=0}^{n_2} b_k(z_1) z_2^k \quad (63)$$

$$Q_1^*(z_1, z_2) = \sum_{k=0}^{n_2} \overline{b_k(z_1)} z_2^k \quad (64)$$

and

$$D^0(z_1, z_2) \Big|_{|z_1|=1} = Q_1 Q_1^* = \sum_{k=0}^{2n_2} \left( \sum_i c_j(z_1^{j+z_1^{-j}}) z_2^k \right) \quad (65)^\dagger$$

where the  $c_j$ 's are constant. Substituting  $z_1 = e^{j\theta}$  in equation (65) to obtain,

<sup>†</sup>It can be shown that for stability  $D_1(x, z_2)$  and  $D_2(x, z_2)$  cannot have a reduction in degree for any  $x$  in  $-1 \leq x \leq 1$ . Therefore, if a reduction of degree occurs in  $D_1(0, z_2)$ ,  $D_2(0, z_2)$  it is not necessary to proceed further with the test.

<sup>††</sup>Note that  $D^0$  has all its  $2n_2$  roots inside the unit circle iff  $Q_1$  has all its  $n_2$  roots inside the unit circle.

$$D^0(z_1, z_2) \Big|_{|z_1|=1} = \sum_{k=0}^{2n_2} \left( \sum_j (2c_j \cos j\theta) z_2^k \right) \quad (66)$$

Using the trigonometric identity,

$$\cos n\theta = \sum_{k=0}^m \binom{n}{2k} (-1)^k \cos^{(n-2k)}\theta \sin^{2k}\theta \quad (67)$$

where  $m = n/2$  for  $n$  even and  $(n-1)/2$  for  $n$  odd. Equation (66) can now be written as:

$$D(x, z_2) = D^0(z_1, z_2) \Big|_{|z_1|=1} = \sum_{k=0}^{2n_2} d_k(x) z_2^k \quad (68)$$

where  $d_k(x)$  are polynomials in  $x = \cos \theta$ . Let

$$D_1(x, z_2) = \frac{1}{2} [D(x, z_2) + z_2^{2n_2} D(x, z_2^{-1})] \quad (69)$$

$$D_2(x, z_2) = \frac{1}{2} [D(x, z_2) - z_2^{2n_2} D(x, z_2^{-1})] \quad (70)$$

### Remarks

1. The checking of the first inequality in region (17) can be performed for the one-dimensional case following Schüssler [63a]. It is given in the following assertion:

Assertion. Let  $D(z)$  be a polynomial of degree  $n$  having real coefficients, and let

$$D(z) = D_1(z) + D_2(z) \quad (71)$$

where

$$D_1(z) = \frac{1}{2} [D(z) + z^n D(z^{-1})] \quad (72)$$

$$D_2(z) = \frac{1}{2} [D(z) - z^n D(z^{-1})] \quad (73)$$



Then  $D(z) \neq 0$  in  $|z| \geq 1$  if and only if all the zeros of  $D_1(z)$  and  $D_2(z)$  are simple, are located on the unit circle  $|z| = 1$ , and also separate each other on the unit circle.<sup>†</sup>

2. Satisfying conditions (1) and (2) of Theorem 8 is equivalent to the polynomial  $D^0(z_1, z_2) \neq 0$  for  $z_1 = j$ ,  $|z_2| \geq 1$ . This is translated in the notation of (18) to the following:

$$Q(b, z_2) \neq 0, \quad \text{for all } |z_2| \leq 1, \quad |b| = |j| = 1 \quad (74)$$

In observing region (18), we arrive at the conclusion that the checking of (3) in Theorem 8 is equivalent to the checking of the last condition of (19). Thus, we have reconciled the stability test of this method to that of regions (17) or (19).

3. One can simplify this test by considering the region of (20).

A similar theorem was also obtained by Bose [55] for the continuous case as in region (39). It is based on the following theorem:

Theorem 9. It is known from before that

$$Q(s_1, s_2) \neq 0, \quad \text{in } \text{Re } s_1 \geq 0, \quad \text{Re } s_2 \geq 0 \quad (75)$$

if and only if:

$$Q(s_1, 1) \neq 0, \quad \text{Re } s_1 \geq 0 \quad (76)$$

$$Q(s_1, s_2) \neq 0, \quad \text{Re } s_1 = 0, \quad \text{Re } s_2 \geq 0 \quad (77)$$

Hence, the theorem states that  $Q(s_1, s_2) \neq 0$  in  $\text{Re } s_1 = 0$ ,  $\text{Re } s_2 \geq 0$  if and only if

---

<sup>†</sup>An algorithm for testing this condition is given by Szezupak-Mitra-Jury in IEEE Trans. on ASSP, vol. ASSP-25, pp. 101-102, Feb. 1977.

- 1) the zeros<sup>†</sup> of  $N_1(1, s_2)$  and  $N_2(1, s_2)$  are located on the line  $\text{Re } s_2 = 0$ ;
- 2) the zeros of  $N_1(1, s_2)$  and  $N_2(1, s_2)$  are simple and alternate on the line  $\text{Re } s_2 = 0$ ; and
- 3) the resultant  $R_1(\omega_1)$  of  $N_1(\omega_1, s_2)$  and  $N_2(\omega_1, s_2)$  has no real roots

where

$$N^0(s_1, s_2) = Q(s_1, s_2)Q^*(s_1, s_2) = \sum_{k=0}^{2n_2} n(\omega_1) s_1^k \quad (78)$$

and

$$N(\omega_1, s_2) = N^0(s_1, s_2) \Big|_{s_1=j\omega_1} \quad (79)$$

$$N_1(\omega_1, s_2) = \frac{1}{2}[N(\omega_1, s_2) + N(\omega_1, -s_2)] \quad (80)$$

$$N_2(\omega_1, s_2) = \frac{1}{2}[N(\omega_1, s_2) - N(\omega_1, -s_2)] \quad (81)$$

Note that equation (76) can be tested using a standard one-dimensional technique by carrying out the continued fraction expansion of  $\text{Ev } Q(s_1, 1)/\text{Od } Q(s_1, 1)$  or  $\text{Od } Q(s_1, 1)/\text{Ev } Q(s_1, 1)$ . If all the coefficients of the continued fraction expansion are positive then  $Q(s_1, 1)$  is a Hurwitz polynomial, or alternatively the fraction is a reactance function.

#### e. Impulse Response Test

In the following discussion we will indicate how the impulse response  $g_{m,n}$  can be used to check the stability of two-dimensional digital filters. These discussions will follow the works of Strintzis[48,64], Goodman [40] and Vidysagar and Bose [65]. First, we discuss the stability of the causal or spatially causal filter of the quarter plane type. Following Strintzis [64], we present the following theorem:

<sup>†</sup> Again for stability,  $N_1(\omega, s_2)$  and  $N_2(\omega, s_2)$  cannot have a reduction in degree for any  $\omega$  in  $-\infty < \omega < \infty$ . Therefore, if a reduction in degree is noticed in  $N_1(1, s_2)$  and  $N_2(1, s_2)$  it is not necessary to proceed further in the test.

Theorem 10. Let  $H$  be the upper limit of the double sequence  $\{|g_{m,n}|^{1/m+n}\}$ :

$$H = \overline{\lim}_{m \text{ and/or } n \rightarrow \infty} |g_{m,n}|^{\frac{1}{m+n}} \quad (82)$$

If  $G(z_1, z_2)^\dagger$  is rational in  $z_1$  and  $z_2$ , the following conditions exist:

(i)  $H < 1$ , the above is necessary and sufficient for convergence of

$$G(z_1, z_2) = \sum_{z_1=0}^{\infty} \sum_{z_2=0}^{\infty} g_{m,n} z_1^m z_2^n \quad (83)$$

in  $\{|z_1| \leq 1, |z_2| \leq 1\}$  and for "BIBO" stability of the filter. If  $H > 1$ , the filter is unstable. Furthermore, as a consequence of (i), we also have

$$(ii) |g_{m,n}| \leq k\mu^{m+n}, \quad 0 \leq k < +\infty, \quad |\mu| < 1. \quad (84)$$

The case where  $H = 1$ , is discussed in the following lemma.

Lemma 1. If  $G(z_1, z_2)$  is rational and if  $H = 1$ , then the unstable singularities may only occur in one of the following regions:

$$1) |z_1| = 1, z_2 \text{ arbitrary} \quad (85)$$

$$2) z_1 \text{ arbitrary}, |z_2| = 1 \quad (86)$$

3) along the perimeter (but not the interior) of the set

$\{|z_1| \leq 1, |z_2| \leq 1\}$ , i.e. when

$$G(z_1, z_2) = \infty \text{ for some } |z_1| = |z_2| = 1 \quad (87a)$$

$$G(z_1, z_2) \neq \infty \text{ if either } |z_1| < 1 \text{ or } |z_2| < 1 \quad (87b)$$

<sup>†</sup>In the following development, we assume that the numerator and denominator of  $G(z_1, z_2)$  are mutually prime and that no non-essential singularities of the second kind in  $|z_1| = |z_2| = 1$  exist.

Based on this lemma, we have

Theorem 11. [40,64]. If  $G(z_1, z_2)$  is rational and not in the class of functions described in (87), the following conditions are all equivalent and each is necessary and sufficient for BIBO stability of the filter:

$$(iii) \quad |g_{m,n}| \rightarrow 0 \text{ when } m \rightarrow \infty, \text{ or } n \rightarrow \infty \quad (88)$$

$$(iv) \quad \sum_{m=0}^{\infty} \sum_{n=0}^{\infty} |g_{m,n}|^p < \infty, \quad p \geq 1 \quad (89)$$

Other relationships related to stability of the impulse response are described by Goodman [40] and a relationship similar to (iv) by Vidyasagar and Bose [65].

The conditions (i-iv) developed earlier may be used directly as stability criteria in the design of two-dimensional filters in the time domain. If the design is based on a frequency-domain characterization

$$G(z_1, z_2) = \frac{P(z_1, z_2)}{Q(z_1, z_2)} \quad (90)$$

where  $Q$  is a polynomial function,

$$Q(z_1, z_2) = \sum_{i_1=0}^{I_1} \sum_{i_2=0}^{I_2} a_{i_1, i_2} z_1^{i_1} z_2^{i_2} \quad (91)$$

and  $P$  is a polynomial bounded in the intersection  $|z_i| \leq 1, i = 1, 2$ , then the filter  $G(z_1, z_2)$  is BIBO if and only if the following filter is stable:

$$\hat{G}(z_1, z_2) = \frac{1}{Q(z_1, z_2)} = \sum_{k_1=0}^{\infty} \sum_{k_2=0}^{\infty} g_{k_1, k_2} z_1^{k_1} z_2^{k_2} \quad (92)$$

On multiplying both sides of (92) by  $Q(z_1, z_2)$  as given in (91) and equating coefficients, we obtain

$$g_{0,0} = \frac{1}{a_{0,0}} \quad (93)$$

$$\sum_{i_1=0}^{I_1} \sum_{i_2=0}^{I_2} g_{n_1-i_1, n_2-i_2} g_{i_1, i_2} = 0 \quad (94)$$

for all  $n_r \geq 0$ ,  $r = 1, 2$  where

$$g_{k_1, k_2} \stackrel{\Delta}{=} 0, \quad \text{if any } k_r < 0, \quad r = 1, 2 \quad (95)$$

We thus obtain the following theorem due to Strinzis [64]:

Theorem 12. Let  $\{g_{k_1, k_2}\}$  be the sequence obtained by the recursive relations (93-95). Either of the following conditions is necessary and sufficient for BIBO stability of (90).

- 1)  $|g_{k_1, k_2}|^{\overline{k_1+k_2}} < 1$  for  $k_1$  and/or  $k_2 \rightarrow \infty$ .
- 2) The polynomial  $Q(z_1, z_2)$  is nonzero for  $|z_1| = |z_2| = 1$ , and  $g_{k_1, k_2}$  approaches zero as one or both indices  $k_{1,2}$  approach infinity.

#### Remarks

1. The recursive relationships in (93-95) can be used to test for stability as indicated in (1) of Theorem 12. The storage required for application of (1) is minimal. This is an advantage in some cases as compared with stability in tests of (a-d) of this section. Criterion (2) of the above theorem is comparable to the checking of equation (19).

2. Conditions (i-iv) of Theorems 10, 11 are different than the one-dimensional case. In particular (iii) and (iv) are not equal to (i) and (ii)

because of Lemma 1.<sup>†</sup> However, the corresponding ones for the one-dimensional case are all equal.

3. Further stability conditions in terms of the impulse response are given in Table 1.

4. Application of the stability test based on the impulse response for one-dimensional polynomials was proposed long ago by Krishnamurthy [66].

To complete the above discussions, we will present a theorem due to Strinzis [48] analogous to (83,84) and (88,89) for asymmetric half-plane filters discussed in part A-b.

To generate an "impulse response" sequence of the filter in equation (22), we need a Taylor's series expansion of  $G(z_1, z_2)$  (we assume that both the numerator and denominator are mutually prime and no non-essential singularities of the second kind on  $|z_1| = |z_2| = 1$  exist),

$$G(z_1, z_2) = \sum_{m=0}^{\infty} z_1^m h_m(z_2) \quad (96)$$

followed by Laurent series expansion of each  $h_m(z_2)$ ,

$$h_m(z_2) = \sum_{n=-\infty}^{n=\infty} g_{mn} z_2^n \quad (97)$$

where one property of  $h_m(z_2)$  is given by:

$$h_m(z_2) = \frac{1}{m!} \left[ \frac{\partial^m}{\partial z_1^m} G(z_1, z_2) \right]_{z_1=0} \quad (98)$$

<sup>†</sup>An example for (87a and b) is given by Goodman [40]. It is as follows:

$$G(z_1, z_2) = \frac{2}{2 - z_1 - z_2}$$

The above filter is BIBO unstable but has a unit sample response  $\{g_{m,n}\}$  such that  $\lim_{m,n \rightarrow \infty} \{g_{m,n}\} = 0$ .

Other properties of  $h_m(z_2)$  also exist, but these are not relevant to the following theorem [48].

Theorem 13. If  $G(z_1, z_2)$  is rational and unless (101) given below are true, then the following conditions are all equivalent and each is necessary and sufficient for the stability of asymmetric half-plane (non-anticipative) filters.

$$\lim_{m \text{ and/or } n \rightarrow \pm\infty} |g_{m,n}| = 0 \quad (99)$$

$$\text{for some } p, 1 \leq p < +\infty, \sum_{m=0}^{\infty} \sum_{n=-\infty}^{\infty} |h_{m,n}|^p < +\infty \quad (100)$$

If there exists

$$\overline{\lim}_m |h_m(z_2)|^{1/m} = 1 \quad (101a)$$

for at least one  $z_2$ ,  $|z_2| = 1$  but for all other  $z_2$ ,  $|z_2| = 1$

$$\overline{\lim}_m |h_m(z_2)|^{1/m} < 1, \quad (101b)$$

then conditions (101a) always imply BIBO instability of the filters, but the

$$\lim_{m, n \rightarrow \infty} \{g_{m,n}\} = 0.$$

#### f. Cepstral Stability Test

It is known that the two-dimensional complex cepstrum can be used for the stabilization of recursive filters. Such studies were conducted by Pistor [31], Dudgeon [46] and Ekstrom and Woods [47,47a]. Furthermore, cepstral analysis has been used in speech processing by Oppenheim et al [67] and more recently it is applied in image processing especially image deblurring by Rom [68].

As in the one-dimensional case, the two-dimensional complex cepstrum is defined as the inverse Fourier transform of the complex logarithm of the two-dimensional Fourier transform of a sequence. Thus, if two sequences are convolved, their cepstra add. For the following discussions we define the two-dimensional z-transform cepstrum  $\hat{G}(z_1, z_2)$  as the logarithm of the two-dimensional z-transform of an array  $g(m, n) \in \ell_1$ :

$$\hat{G}(z_1, z_2) = \ell_n [Z\{g(m, n)\}] = \ell_n [G(z_1, z_2)] \quad (102)$$

In the works of Pistor [31] and Ekstrom and Woods [47] on two-dimensional spectral factorization, they have shown how such a factorization can be used for obtaining a stability theorem for two-dimensional recursive filters. Pistor [31] gave such a criterion mentioned below and Ekstrom and Woods [47], and later Ekstrom and Twogood [69], gave algorithms for the stability test. In the following discussions we will principally follow the algorithm of Ekstrom and Twogood [69].

Theorem 14 [31]. The quantity  $\{l_q(m, n)\}_{\substack{m>0 \\ n>0}}$  is recursively stable if and only if there exists a power series

$$\sum_{m=0}^{\infty} \sum_{n=0}^{\infty} \hat{q}_{m,n} z_1^m z_2^n \quad (103)$$

that is absolutely convergent and equal to  $\ell_n Q_1(z_1, z_2)$  for all  $(z_1, z_2)$  such that  $|z_1| \leq 1$ ,  $|z_2| \leq 1$  where  $q(m, n)$  is a first quadrant sequence and  $\{\hat{q}_{m,n}\}$  is the inverse z-transform of  $\hat{Q}(z_1, z_2)$ , i.e.

$$\{\hat{q}_{m,n}\} \leftrightarrow \hat{Q}(z_1, z_2) = \ell_n Q(z_1, z_2) \quad (104)$$

In the above  $Q(z_1, z_2)$  represents the denominator of the causal filter  $F(z_1, z_2) = 1/Q(z_1, z_2)$ .



Corollary 2 [31]. The  $\ell^{\text{th}}$  quadrant function  $q_{m,n}^{\ell}$  in which  $\ell = 2, 3, 4$  is recursively stable if and only if  $\ell_n[Q_1(z_1, 1/z_2)]$ ,  $\ell_n[Q_2(1/z_1, 1/z_2)]$  or  $\ell_n[Q_3(1/z_1, z_2)]$ , respectively, are equal to a power series of the form (103) that is absolutely convergent for all  $(z_1, z_2)$  in  $|z_1| \leq 1$ ,  $|z_2| \leq 1$ .

Though the above theorem and corollary of Pistor [31] are of interest, he did not present an algorithm for testing stability. Such a test was later obtained by Ekstrom and Woods [47] as an application of the two-dimensional spectral factorization. It is based on a two-dimensional factorization operation involving the autocorrelation function of the filter which covers both the quarter and half planes. By using the autocorrelation of the filter, this test involved calculating the logarithm of a real array. While this introduced substantial complexity into the computation, it did avoid the problems associated with defining the complex logarithm. Recently Dudgeon [70] has shown the existence of a two-dimensional complex cepstrum. Based on such existence, Ekstrom and Twogood [69] have obtained an alternate test which removes the earlier complexity and is computationally attractive. In the following, we will present in detail this test.

Cepstral Test [69]. For stability considerations, the important property of the cepstral transformation is that the nonessential singularities and zeros of  $G(z_1, z_2)$  map into the essential singularities and zeros of  $\hat{G}(z_1, z_2)$ . Because of this, the regions of analyticity of  $G(z_1, z_2)$  and  $\hat{G}(z_1, z_2)$  are identical. Now if  $G(z_1, z_2)$  is a stable filter, it can be written in a power series for  $m, n \in \mathbb{R}$  (where  $\mathbb{R}$  is the region of support of the filter, whether a quarter-plane or asymmetric half-plane) and hence  $\hat{G}(z_1, z_2)$  can be similarly expanded:

$$\hat{G}(z_1, z_2) = \sum_{\mathbb{R}} \hat{g}(m, n) z_1^m z_2^n \quad (105)$$

The above leads to the following theorem which gives the stability test.

Theorem 15 [69]. The asymmetric half-plane recursive filter  $G(z_1, z_2) = \frac{1}{Q(z_1, z_2)}$  is stable if and only if its cepstrum  $\hat{g}(m, n)$  has support on  $\mathbb{R}$ .

Because  $\hat{G}(z_1, z_2)$  is analytic on  $\{|z_1| = 1, |z_2| \leq 1\}$ ,  $\hat{g}(m, n)$  takes support on the entire half plane (in this case the half-plane defined by  $\{m \geq 0, n \geq 0\} \cup \{m < 0, n > 0\}$ ). The additional region of analyticity for  $\hat{G}(z, 0)$  on  $\{|z_1| \leq 1\}$  ensures that  $\hat{g}(m, n) = 0$  for  $n < 0$ . The above theorem can be generalized to other classes of half-plane and quarter-plane filters.

The implementation of this theorem into stability test proceeds as follows. 1. Form  $Q(z_1, z_2)$  from  $q(m, n)$  of the filter to be tested for stability. 2. Calculate  $\hat{Q}(z_1, z_2)$  and then its inverse z-transform to obtain the cepstrum  $\hat{q}(m, n)$ . If  $\hat{q}(m, n) = 0$ , for  $m, n \notin \mathbb{R}$ , then the filter is stable. If  $q(m, n) \neq 0$  for  $m, n \notin \mathbb{R}$ , then the filter is unstable. In the numerical realization of the test, one can replace the z-transforms with the DFT (discrete Fourier Transform) as shown in Figure 6. In this figure  $\hat{q}_a(m, n)$  is the aliased version of  $\hat{q}(m, n)$ . The difference can be calculated from the size of DFT.

In order to ensure the analyticity of  $\hat{Q}(u, v)$  which is equal to

$$\hat{Q}(u, v) = \ell_n Q(u, v) = \ell_n |Q(u, v)| + j \arg Q(u, v) \quad (106)$$

the phase term,  $\arg Q(u, v)$ , must be periodic and continuous as shown by Dudgeon [70]. To ensure continuity one can use a method called phase unwrapping [69], and to ensure periodicity (with period  $2\pi$ ), one uses the method of linear phase removal [70]. A method for accomplishing this is reported by Ekstrom and Twogood [69] with numerical examples for performing the stability test.

Remarks

1. The cepstral method is mainly applicable for numerical testing for stability. As such, it is not amenable to obtain stability inequality conditions as can be done (for low order polynomials)<sup>†</sup> using the tests (a-d).

2. This method is an approximate method and thus it might be less reliable than the methods of (a-d). The latter methods can also be approximate when the zeros of the polynomials are near the boundaries of the regions of analyticity. However, several effective numerical methods are known to give in this case precise results.

3. A computational comparison between a former complicated test of Ekstrom and Woods [47] with the table form of Maria and Fahmi [63] showed the cepstral method to be more efficient. However, this comparison is made with the complicated procedure of Maria and Fahmy (i.e. without taking computational advantages of the positive Hermitian matrix) and thus a new comparison of the present method and Šiljak's table form is indeed warranted.

In spite of some minor drawbacks of the cepstral method, it is very useful and indeed it has potential for applications in problems other than stability.

g. Nyquist-Like Test

It is well known that the Nyquist criterion gives information on the stability of one-dimensional discrete and continuous systems by graphically plotting the Nyquist locus in the  $z$  or  $s$ -planes. In a series of articles, R.A. DeCarlo, J. Murray and R. Sacks [45,71,72] have clearly extended the Nyquist mapping to determine the stability of two-dimensional as well as multi-dimensional scalar polynomials. The key to their formulation of the Nyquist-like theory is the observation that from an abstract analytical

---

<sup>†</sup>See eqns. (120) and (121).

functional point of view the classical one-variable Nyquist plot is simply a method for determining whether or not an analytic function in one variable has zeros in an appropriate region by plotting the image of the function on the boundary of the region. To obtain a Nyquist theory in two dimensions, one can decompose the region of  $C^2$ , in which  $Q(z_1, z_2)$  of equation (17) is forbidden to have zeros as a union of a family of one-variable regions to which the classical Nyquist theorem applies. Here, we define the disc  $D_\alpha$  in  $C^2$ , for real  $\alpha$ ,  $0 \leq \alpha \leq 2\pi$ , by

$$D_\alpha = \{(e^{j\alpha}, z_2), |z_2| \leq 1\} \quad (107)$$

and we define the disc  $D$  by

$$D = \{(z_1, 0), |z_1| \leq 1\} \quad (108)$$

corresponding to the region of analyticity in equation (17). Based on the above observation, we have

Theorem 16 [71]. A digital filter characterized by the two-dimensional transfer function  $G(z_1, z_2) = \frac{P(z_1, z_2)}{Q(z_1, z_2)}$  (with the assumptions indicated in a.2) is structurally stable, if and only if the Nyquist plots for the family of one-dimensional functions

$$Q(e^{j\alpha}, z_2), \quad 0 \leq \alpha < 2\pi \quad (109)$$

and

$$Q(z_1, 0)$$

do not equal or encircle zero in the complex plane.

We can also obtain other graphical tests for stability by invoking the analyticity regions of (18-20). This leads to the following theorems:

Theorem 17 [45,72]. The two-dimensional digital filter described above is structurally stable if and only if

$$(i) \quad Q(z_1, z_2) \text{ has no zeros on } |z_1| = |z_2| = 1 \quad (110)$$

(ii) The Nyquist plots for the one-dimensional functions  $Q(1, z_2)$  and  $Q(z_1, 0)$  do not encircle zero. (111)

In the test of (i), we check the image of the distinguished boundary. It is indeed the two-dimensional frequency response and can be obtained graphically.

Theorem 18 [72]. Let  $Q$  be as above. The filter is structurally stable if and only if

$$(i) \quad Q(z_1, z_2) \text{ has no zeros on the distinguished boundary.}$$

(ii) The Nyquist plots for the one-dimensional functions  $Q(1, z_2)$  and  $Q(z_1, 1)$  do not encircle zero.

Actually the regions of analyticity of the above two theorems are readily obtainable by special cases from the regions of (18).

Theorem 19 [72]. Let  $Q$  be as above. Then the filter is structurally stable if and only if

$$(i) \quad Q \text{ has no zeros on the distinguished boundary.}$$

(ii) The Nyquist plot for the single variable function  $Q(z, z)$  does not encircle zero.

### Remarks

1. Because the Nyquist plot is related to the frequency response, it appears that the above tests are useful not only for checking stability but for design purposes where certain changes in the frequency response are

required. Also, the extension of the above theorems to multidimensional digital filters will be explored in the next section.

2. Though DeCarlo et al have presented the Nyquist-like tests for the digital filters, similar tests can be readily obtained for two- and multi-dimensional continuous filters. Furthermore, the Nyquist-like can be extended to some other regions of analyticity than the one quarter plane region discussed by the above authors.

#### h. Stabilization of Unstable Filters

In an effective design of two-dimensional digital filters, it is often required to stabilize an unstable filter without perturbing the magnitude of the frequency response or to guarantee a stable filter. In the one-dimensional case, this is accomplished by cascading the unstable filter with a digital all-pass filter which has no effect on the magnitude of the frequency response and which guarantees stability. Of course, there exist other procedures for accomplishing this. In the two-dimensional case, there are difficulties in extending the approaches used for the one-dimensional case. These difficulties are mainly due to the inability to factor a two-dimensional polynomial.

The approaches used for trying to stabilize an unstable two-dimensional digital filter without affecting the frequency response are of three kinds, namely, the two-dimensional discrete Hilbert transform, the two-dimensional complex cepstrum method and the planar least square inverse (PLSI) method. Unfortunately, all three methods are plagued with difficulties inherent for two-dimensional polynomials.

Read and Treitel [73] have defined a two-dimensional discrete Hilbert transform to be used for the stabilization of recursive filters. The basis

of this method is to obtain a log-magnitude function of the denominator polynomial of the filter and use the two-dimensional discrete Hilbert transform to calculate the minimum phase (i.e. stable) function associated with that log-magnitude function. A new denominator polynomial is then constructed by a complex exponentiation. In many cases the reconstructed minimum phase denominator polynomial is infinite. Furthermore in a discussion by Bose [74] and Woods [74a], it is indicated that the magnitude function is impaired. A recent work by Murray [74b] shed more light on this problem.

The complex spectrum approach was first used by Pistor [31] and Dudgeon [46] and later on by Ekstrom and Wood [47a]. The basic idea of this approach is to use the two-dimensional cepstra to decompose the magnitude-squared frequency responses to get stable recursive two-dimensional filters. The Pistor decomposition was made of four stable recursive one-quadrant filters while the Dudgeon decomposition was made of half-plane filters. Ekstrom and Woods, using the concept of canonical spectral factorization, decomposed the filter into several forms which included the above cases as well as asymmetric ones. The resulting factors are recursively computable and of minimum phase (i.e. stable). In all the various decomposition methods, the factors, though recursively computable and stable, are generally infinite dimensional. Hence, truncation is used by the above authors for the recursive filter. This truncation evidently changes the magnitude function and in some cases the truncated factors are unstable. To avoid this, Ekstrom and Woods have introduced windowing. It involves both a truncation and a smoothing. A weighting factor is applied to the truncated array which smooths out perturbations in the frequency spectra introduced by the truncation and tends to stabilize the truncated filters.<sup>†</sup>

Another stabilization procedure is based on a conjecture due to Shanks et al [75]. The conjecture states that the planar least squares inverse (PLSI)

---

<sup>†</sup>Further refinement of this method is contained in the Ph.D. thesis of R. E. Twogood, "Design and implementation techniques for 2-D digital filters," Dept. of EE, U. C. Davis, Nov. 1977.

of an array is a minimum phase array (i.e. stable). To illustrate this we assume that we have an unstable filter

$$G(z_1, z_2) = \frac{P(z_1, z_2)}{Q(z_1, z_2)} \quad (112)$$

which we want to stabilize. Letting  $q(m,n)$  denote the coefficients of the denominator, we seek an inverse to  $q$ , denoted  $b$  such that

$$\delta(m,n) \cong q(m,n) ** b(m,n) \quad (113)$$

where  $**$  denotes the two-dimensional convolution. The filter  $b(m,n)$  is chosen to minimize the error in the above equation. If  $b$  is chosen to minimize the mean-squared error

$$e = \sum_{m,n} [g(m,n) - q(m,n) ** b(m,n)]^2, \quad (114)$$

then it is referred to as the PLSI of  $q(m,n)$ . By the conjecture,  $b(m,n)$  is a minimum phase array (i.e. stable). To stabilize an unstable filter, Shanks et al [75] proposed taking the double PLSI of the denominator array. This double inversion will yield a stable filter and the frequency response of the final result will hopefully approximate the original frequency response. The final frequency response will be an approximation to the original one and in some cases might not be a good approximation. In these cases an improvement is achieved by increasing the degree of the intermediate PLSI filter. While the conjecture was not proven for the two-dimensional case, it has been proven for the one-dimensional case. This conjecture has been used in the design of many filters and has been discussed by Bednar [76]. In a later work Genin and Kamp [77] came up with a counterexample. Furthermore, they made use of the properties of orthogonal polynomials of



two-dimensions to disprove the conjecture in general [78]. Furthermore, Anderson-Jury [79], and Jury et al [80] have proved the conjecture for low degree polynomials. In examining the failure of the conjecture in the Genin and Kamp [77] counterexample, Jury [81] has proposed a new conjecture which is the same as that of Shanks' except with the added condition that the inverse polynomial of  $b(m,n)$  to be chosen is of the same degree as the original polynomial of  $q(m,n)$ . So far no counterexample has been obtained. Also in [81], Jury discussed the mathematical difficulties in proving the conjecture with the added condition. Hence, it appears that the design approach using this method still remains unsolved.

With the above, we close the stability discussion of the two-dimensional polynomials and in the next section we examine the stability of multi-dimensional scalar polynomials.

#### IV. Stability of Multidimensional Polynomials (Scalar Case)

Stability problems of polynomials of dimensions higher than two arise in several applications. The importance and need for multidimensional digital filtering in certain areas like seismology have already been discussed [82,83]. Hence stability problems associated with such filters need be considered. Other applications arise in obtaining realizability properties of impedances of networks and transmission lines, where the transmission lines are of incommensurate lengths [84] and in the realizability condition of multivariable positive real functions [38]. Also in problems connected with the numerical integration method of difference-differential equations, we encounter the stability of multidimensional polynomials [51]. Other related problems arise in the output feedback stabilization [39,85,86].

Analogously with the two-dimensional stability of the earlier discussion, we will present first the various regions of analyticity for the discrete filter followed by the continuous one. In the last part of this section, we will present the various stability tests and their computational aspects. Since the generalization of regions of analyticity from the two-dimensional case is straightforward, in the first two parts of this section the review will be succinct.

In the next three sections, similar reviews of stability of multidimensional polynomials for the matrix case will be explored where most of the results of this and the earlier two sections are readily applicable.

##### A. Stability of Multidimensional Digital Filters

In the following discussions we will enumerate the various regions of analyticity for the multidimensional digital filter in the order of their early developments. The first authors who indicated such a region for

non-causal digital filters were Justice and Shanks [32]. They expressed such a region for the denominator polynomial of the multidimensional discrete transfer function  $G(z_1, z_2, \dots, z_n)$  as follows:

Theorem 20 [32].

$$Q(z_1, \dots, z_n) \neq 0, \quad \left\{ \bigcap_{i=1}^r |z_i| \leq 1 \right\} \cap \left\{ \bigcap_{i=r+1}^s |z_i| \geq 1 \right\} \cap \left\{ \bigcap_{i=s+1}^n |z_i| = 1 \right\} \quad (115)$$

### Remarks

1. In equation (115),  $r+s-r+n-s = n$  (where  $n$  is the number of the dimensions). For

$$G(z_1, z_2, \dots, z_n) = \frac{P(z_1, z_2, \dots, z_n)}{Q(z_1, z_2, \dots, z_n)} \quad (116)$$

where  $P$  and  $Q$  are mutually prime and no nonessential singularities of the second kind on the distinguished boundary of the polydisc exist, the impulse response of the filter described by equation (116), i.e.  $g(m, n, k, \dots) \in \ell_1$ , or

$$\sum_m \sum_n \dots \sum_k |g(m, n, k, \dots)| < \infty \quad (117)$$

2. The above theorem is a generalization of the region given in equation (26). The authors did not present any algorithm or method for testing the region (115). This will be discussed later on.

In a subsequent work by Anderson-Jury [87], a generalization of both Shanks et al [75] as well as of Huang's theorem [30] was obtained. In addition, in this work a method for checking this generalization was outlined. Here we give the salient theorems of this work. The generalization of Shanks' two-dimensional stability theorem is given by:

$$Q(z_1, \dots, z_n) \neq 0, \quad \bigcap_{i=1}^n |z_i| \leq 1 \quad (118)$$

In essence the above is a generalization of the region described in equation (16). This region is related to the stability of the causal quarter-plane.

Theorem 21 [87]. The analyticity region of equation (118) is equivalent to:

$$\begin{aligned}
 Q(z_1, 0, \dots, 0) &\neq 0, & |z_1| &\leq 1 \\
 Q(z_1, z_2, 0, \dots, 0) &\neq 0, & \{|z_1| = 1\} \cap \{|z_2| \leq 1\} \\
 &\vdots \\
 Q(z_1, z_2, \dots, z_{n-2}, 0, 0) &\neq 0, & \{\bigcap_{i=1}^{n-3} |z_i| = 1\} \cap \{|z_{n-2}| \leq 1\} \\
 Q(z_1, z_2, \dots, z_{n-1}, 0) &\neq 0, & \{\bigcap_{i=1}^{n-2} |z_i| = 1\} \cap \{|z_{n-1}| \leq 1\} \\
 Q(z_1, z_2, \dots, z_n) &\neq 0, & \{\bigcap_{i=1}^{n-1} |z_i| = 1\} \cap \{|z_n| \leq 1\}
 \end{aligned} \tag{119}$$

The region of (119) is a generalization of the region of equation (17). It is a generalization of Huang's conditions [30].

In a subsequent and independent work, Takahashi and Tsujii [87a] have obtained similar generalizations as in equation (119). They also discussed in detail the computational complexity for testing this condition. Furthermore, they obtained the stability conditions of a certain three-dimensional polynomial with literal coefficients. These conditions are given below: Let

$$Q(z_1, z_2, z_3) = 1 + az_1 + bz_2 + cz_3 + dz_1z_2 + ez_2z_3 + fz_3z_1 + gz_1z_2z_3 \tag{120}$$

The necessary and sufficient condition for structural stability of  $G(z_1, z_2, z_3)$  whose denominator given in equation (120) is given by the following inequalities (after minor corrections) [87a]

$$|a| < 1, \quad \left| \frac{1-a}{b-d} \right| > 1, \quad \left| \frac{1+a}{b+d} \right| > 1$$

$$A < 0, \quad B < 0, \quad C < 0, \quad E < 0$$

$$D^2 < -4B + 4AE + 8AC\sqrt{BE}$$

$$\begin{aligned} \text{where } A &= (c-e-f+g)^2 - (1-a-b+d)^2 \\ B &= (c+e-f-g)^2 - (1-a+b-d)^2 \\ C &= (c-e+f-g)^2 - (1+a-b-d)^2 \\ D &= 8(d+fe-ab-cg) \\ E &= (c+e+f+g)^2 - (1+a+b+d)^2 \end{aligned} \tag{121}$$

It is of interest to note that the stability inequalities for two first degree two-dimensional polynomials was presented by Huang [30]. They are obtained as special cases of (121). The above shows the formidable complexity which arises when higher dimensions are considered.

In an independent and almost simultaneous works both Strinzis [44] and DeCarlo et al [45] have obtained a region which is simpler computationally than Anderson-Jury. This region is a generalization of the region in equation (19) and is given by the following theorem:

Theorem 22 [44,45]. The following set of conditions are equivalent to equations (118) and (119):

i) for some  $b_1, \dots, b_n$  such that  $|b_r| = 1$ ,  $r = 1, \dots, k$  and for all  $i$ ,  $i = 1, \dots, n$

$$Q(z_1, \dots, z_n) \neq 0 \text{ when } z_r = b_r, \quad r \neq i \text{ and } |z_i| \leq 1 \tag{122}^\dagger$$

ii)  $Q(z_1, \dots, z_n) \neq 0$  when  $|z_1| = |z_2| = \dots = |z_n| = 1$

For simplicity one can choose  $b_r = 1$ .

<sup>†</sup>It is of interest that computationally condition (ii) with the last condition of (i), i.e.,  $Q(1, 1, \dots, z_n) \neq 0$   $|z_n| \leq 1$ , is equivalent to:

$$Q(z_1, z_2, \dots, z_n) \neq 0, \text{ when } |z_1| = |z_2| = \dots = |z_{n-1}| = 1 \text{ and } |z_n| \leq 1.$$

The above is exactly the last condition of (119).

In the enlightening works of DeCarlo, Murray and Saeks [45] and Murray [43a], the authors have obtained other regions which are simpler than in the above theorem. One such region is the generalization of equation (20).

Theorem 23 [43a,45]. The following set of conditions is equivalent to equations (118) and (119):

$$\begin{aligned} \text{i)} \quad & Q(z, z, \dots, z) = 0, \quad |z| \leq 1 \\ \text{ii)} \quad & Q(z_1, z_2, \dots, z_n) \neq 0, \quad |z_1| = |z_2| = \dots = |z_n| = 1 \end{aligned} \quad (123)$$

Along the same lines as above, Strinzis [44] had obtained another region equivalent to equation (115) which is computationally simpler. It is given in the following theorem:

Theorem 24 [44]. The following set of conditions is equivalent to (115), for some  $b_1, \dots, b_k$ ,  $|b_r| = 1$ ,  $r = 1, 2, \dots, n$  and

$$\begin{aligned} \text{i)} \quad & \text{for each } i, \quad i = 1, 2, \dots, r \\ & Q(z_1, \dots, z_n) \neq 0 \text{ when } |z_i| \leq 1 \text{ and } z_r = b_r, \quad r \neq i \\ \text{ii)} \quad & \text{for each } i, \quad i = r+1, \dots, s \\ & Q(z_1, \dots, z_n) \neq 0 \text{ when } |z_i| \geq 1 \text{ and } z_r = b_r, \quad r \neq i \\ \text{iii)} \quad & Q(z_1, \dots, z_n) \neq 0 \text{ when } |z_1| = |z_2| = \dots = |z_n| = 1 \end{aligned} \quad (124)$$

Another form of noncausal multidimensional linear filters (processors) is presented by S.S.L. Chang [50]. Such processors are said to be stable if the impulse response decreases exponentially in all 2-n directions. In this case the region of analyticity is a generalization of equation (31) and is given by the following:

$$Q(z_1, z_2, \dots, z_n) \neq 0 \quad \text{for all } |z_1| = |z_2| = \dots = |z_n| = 1 \quad (125)$$

In concluding this part, it is pertinent to mention the following remarks:

1. The above regions for multidimensional stability of digital filters are the only ones known up to the present time. They generalize the regions of two-dimensional stability except the region of a symmetric half-plane of equation (25). It is hoped that such a generalization will be forthcoming. It is expected that as more applications develop more regions of analyticity will be defined.

2. In most of the stability regions, the stability tests of equations similar to (125) are the most significant. All other conditions are stability tests of one-dimensional digital filters. Hence, the test of  $Q(z_1, \dots, z_n) \neq 0$  for all  $|z_i| = 1, i = 1, 2, \dots, n$ , will be one of the major items of the stability tests in the last part of this section.

#### B. Stability of Multidimensional Continuous Filters

In this part we will obtain the region for a multidimensional "Hurwitzian" polynomial which is a generalization of the region in equation (35). We will also obtain a generalization of the region in (39). In addition, we will obtain the region for multivariable positive real functions (MPRF) [25].

The condition for a multidimensional polynomial to be Hurwitzian is expressed following Anderson-Jury [87] as follows<sup>†</sup>:

$$Q(s_1, s_2, \dots, s_n) \neq 0, \quad \bigcap_{i=1}^n \operatorname{Re} s_i \geq 0 \quad (126)$$

It is conjectured that the above condition gives the necessary and sufficient condition for structural stability of  $G(s_1, \dots, s_n)$ , whose denominator is expressed in equation (126). A generalization of equation (39) is given by Anderson-Jury [87] as follows:

<sup>†</sup>Because of the difficulties inherent in the use of double bilinear transformation as mentioned in the footnote of p. 24, the proof of eq. (126) is lacking.

The condition of (126) is equivalent to the following:

$$\begin{aligned}
 & Q(s_1, 1, \dots, 1) \neq 0, \quad \operatorname{Re} s_1 \geq 0 \\
 & \quad \vdots \\
 & Q(s_1, s_2, \dots, s_{n-2}, 1, 1) \neq 0, \quad \left\{ \bigcap_{i=1}^{n-3} \operatorname{Re} s_i = 0 \right\} \cap \{ \operatorname{Re} s_{n-1} \geq 0 \} \\
 & Q(s_1, s_2, \dots, s_{n-1}, 1) \neq 0, \quad \left\{ \bigcap_{i=1}^{n-2} \operatorname{Re} s_i = 0 \right\} \cap \{ \operatorname{Re} s_{n-1} \geq 0 \} \\
 & Q(s_1, s_2, \dots, s_n) \neq 0, \quad \left\{ \bigcap_{i=1}^{n-1} \operatorname{Re} s_i = 0 \right\} \cap \{ \operatorname{Re} s_{n-1} \geq 0 \}
 \end{aligned} \tag{127}$$

In the works of Strintzis [44], the above is further simplified to give the following region:

- i) for some sequence of real numbers  $w_1, \dots, w_n$  and for each  $i$ ,  
 $i = 1, \dots, n$

$$Q(s_1, \dots, s_n) \neq 0 \text{ when } s_r = jw_r, r \neq i \text{ and } \operatorname{Re}[s_i] \geq 0 \tag{128}$$

- ii)  $Q(s_1, \dots, s_n) \neq 0$  when  $\operatorname{Re}[s_1] = \operatorname{Re}[s_2] = \dots = \operatorname{Re}[s_n] = 0$

In particular, if we choose  $w_1 = \dots = w_n = 0$ , the stability conditions are:

$$\begin{aligned}
 & Q(s_1, 0, \dots, 0) \neq 0 \quad \text{when } \operatorname{Re}[s_1] \geq 0 \\
 & Q(0, s_2, 0, \dots, 0) \neq 0 \quad \text{when } \operatorname{Re}[s_2] \geq 0 \\
 & \quad \vdots \\
 & Q(0, 0, \dots, 0, s_n) \neq 0 \quad \text{when } \operatorname{Re}[s_n] \geq 0 \\
 & Q(s_1, s_2, \dots, s_n) \neq 0 \quad \text{when } \operatorname{Re}[s_1] = \dots = \operatorname{Re}[s_n] = 0
 \end{aligned} \tag{129}$$

In the investigations of the multivariable (multidimensional) positive real function (MPRF), which is given by

$$Z(s_1, s_2, \dots, s_n) = \frac{P(s_1, \dots, s_n)}{Q(s_1, \dots, s_n)} \tag{130}$$



it is known following Bose [25], that to test one of the conditions for positive realness, we require:

$$Q(s_1, \dots, s_n) \neq 0, \quad \bigcap_{i=1}^n \operatorname{Re} s_i > 0 \quad (131)$$

The above condition is required for

$$\operatorname{Re} Z(s_1, \dots, s_n) \geq 0 \quad \text{in} \quad \bigcap_{i=1}^n \operatorname{Re} s_i > 0 \quad (132)$$

Remark

It is often simpler to determine first whether  $Q(s_1, \dots, s_n) \neq 0$  in  $\bigcap_{i=1}^n \operatorname{Re} s_i \geq 0$ . If  $Q(s_1, \dots, s_n)$  is devoid of zeros in  $\bigcap_{i=1}^n \operatorname{Re} s_i \geq 0$  (utilizing equation (129)), then it is possible to replace the test for equation (132) by the simpler test for

$$\operatorname{Re} Z(j\omega_1, j\omega_2, \dots, j\omega_n) \geq 0 \quad \text{for all real } \omega_1, \omega_2, \dots, \omega_n \quad (133)$$

C. Stability Tests for Multidimensional Polynomials

In this part we will extend the various stability tests mentioned in (III-D) to the multidimensional polynomials. Though this extension is straightforward, the computational effort becomes exceedingly complicated as the dimension increases. Also we will discuss the tests for the various regions of analyticity discussed in part A and B of this section.

a. Symmetric Matrix Form [88]

The first application of this method to stability tests for three-dimensional polynomials was made by Bose-Jury [88]. In applying this test to equation (119), we have to test for the following equation:

$$Q(z_1, z_2, z_3) \neq 0, \quad \left\{ \bigcap_{i=1}^2 |z_i| = 1 \right\} \cap \{ |z_3| \leq 1 \} \quad (134)$$

The test involves applying the Schur-Cohn matrix to the following equation:

$$Q(z_1, z_2, z_3) = \sum_{i=0}^P a_i(z_1, z_2) z_3^i \quad (135)$$

Using the same procedure as in the two-dimensional case, we obtain the Schur-Cohn matrix which is Hermitian as a function of the variables  $z_1$  and  $z_2$ , where  $|z_1| = |z_2| = 1$ . This matrix ought to be checked for positive (negative) definiteness. This indicates that the determinant ought to be positive for all  $|z_1| = |z_2| = 1$ . This can be accomplished by the use of the following lemma.

Lemma 2 [88]. The real function,  $g_1(z_1, z_1^{-1}, z_2, z_2^{-1}) > 0$ ,  $\cap |z_1| = 1$  if and only if the self-inversive polynomial,  $^\dagger g(z_1, z_2) = z_1^{n_1} z_2^{n_2} g_1(z_1, z_1^{-1}, z_2, z_2^{-1})$ , evaluated at any arbitrary point  $z_1 = z_1^{(0)}$  on  $|z_1| = 1$  has exactly  $n_2/2$  zeros in each of the domains  $|z_2| < 1$  and  $|z_2| > 1$ , and  $g(1, 1, 1, 1) > 0$ . [For convenience, this lemma is stated for the case when no degree reduction takes place. If such a case occurs, then the lemma can be modified to account for the critical case].

Based on the above lemma the stability test for the three-dimensional polynomial using equation (119) can be carried out in terms of root distribution with respect to the unit circle. In the general case, one has to determine the positivity of  $(n-1)$  dimensional real functions. To do this for  $n > 3$ , Bose-Jury [88] pointed out the use of decision algebra of Tarski-Seidenberg to accomplish this. The application of this method to the stability of multidimensional discrete and continuous systems was discussed by

<sup>†</sup>A real multivariable polynomial  $Q(z_1, z_2, \dots, z_{n-1})$  will be called self-inversive if and only if a zero of  $Q(z_1, z_2, \dots, z_{n-1})$  at  $(z_1^{(0)}, z_2^{(0)}, \dots, z_{n-1}^{(0)})$  implies also a zero at  $(1/z_1^{(0)}, 1/z_2^{(0)}, \dots, 1/z_{n-1}^{(0)})$ .

Bose-Jury [89], and to other problems was discussed by Anderson-Bose-Jury [39].

Similar discussions arise for testing the region of equation (127) (i.e. for the continuous case). For the three-dimensional filter, we have to test the positiveness of:

$$D(\omega_1, \omega_2) > 0, \quad \bigcap_{i=1}^2 -\infty < \omega_i \leq \infty \quad (136)$$

where

$$D(\omega_1, \omega_2) = D(-\omega_1, -\omega_2) \quad (137)$$

For the n-dimensional case, we have to check the positivity of (n-1) dimensional real functions for positivity for all the real variables  $\omega_i$ . This is referred to as global positivity. This method of symmetric matrix form can be also applied for checking other regions mentioned in parts A and B.

b. Innerwise Matrix Forms [54,56]

This approach is extensively used by Bose and his collaborators in ascertaining both global positivity, nonglobal or local positivity (this refers to positivity confined to a proper interval of the real variable  $\mathbb{R}$ ), or nonnegativity as in equation (132).

The basis of this work is to use the inners determinants to ascertain the distinct number of real roots. If this number is zero then global positivity is ascertained [56]. For non-negativity, Modaressi and Bose [90] have shown that it is reducible to positivity by increasing the dimension by one. For local positivity Modaressi and Bose [58] and Modaressi [57] have shown the use of the inners theory to ascertain this required test. Furthermore, they examined all the critical cases that arise from degree reduction and others.

Of importance in this work is the proof of the following lemma due to Bose and Basu [54].

Lemma 3.  $Q(z_1, \dots, z_n)$  is devoid of zeros on  $\bigcap_{i=1}^n |z_i| = 1$  if and only if  $Q_n(x_1, \dots, x_n)$  is devoid of zeros in

$$-1 \leq x_1 \leq 1, -1 \leq x_2 \leq 1, \dots, -1 \leq x_n \leq 1, \quad (138)$$

simultaneously where

$$\begin{aligned} Q_1(x_1, z_2, z_3, \dots, z_n) &= Q(z_1, z_2, \dots, z_n) Q(\bar{z}_1, z_2, \dots, z_n) \\ Q_2(x_1, x_2, z_3, \dots, z_n) &= Q_1(x_1, z_2, \dots, z_n) Q_1(x_1, \bar{z}_2, \dots, z_n) \\ &\vdots \\ Q_n(x_1, x_2, \dots, x_n) &= Q_{n-1}(x_1, x_2, \dots, x_{n-1}, z_n) Q_{n-1}(x_1, x_2, \dots, x_{n-1}, \bar{z}_n) \end{aligned} \quad (139)$$

where  $(\bar{z}_i)$  denotes the complex conjugate of  $z_i$  implying that  $-1 \leq x_i \leq 1$  when  $|z_i| = 1$ , and  $x_i = \frac{z_i + \bar{z}_i}{2}$  on  $|z_i| = 1$ .

The above lemma enables us to ascertain the stability of the multi-dimensional discrete filters by testing the local positivity of another multidimensional polynomial. Furthermore, by using direct test formulation the authors have also tested the region given in equation (125).

### Remarks

1. Though the inners approach can be used to check multidimensional stability of both discrete and continuous systems by rational operations, for practical use, it becomes computationally prohibitive for  $n$  larger than three or four. This is due to treating a plethora of critical cases.
2. Because of this difficulty, other methods for checking global and local positivity using resultant theory and minimization techniques are developed. These methods will be briefly reviewed later on.

c. Table Form for Stability Test

The use of the table form of the Cohn-Marden-Jury for the discrete case when  $n = 4$  was first introduced in Anderson-Bose-Jury [39] and later on by Bose-Kamat [91]. In the latter work an algorithm with a view toward computer implementation is given. The algorithm is based on the generation of a number of multidimensional polynomials, reduction of each of these into several single dimensional polynomials by a finite number of rational operations. Thus the ideas of decision algebra theory were the basis of this reduction. It seems that the computational complexity of such an approach is more than the inners method discussed in (b). The same is true when one uses a Routh type of array in the extraction of the "GCD" factor from two multivariable polynomials. A related work on the use of the table form in discrete and continuous systems is discussed by Šiljak [92].

d. Local Positivity Method

This method which was discussed earlier for two-dimensional polynomials has not been extended to the multidimensional case. It is believed that using the regions in (122) and (123) and noting (138) and (139) one can obtain such a generalization. This is left for future research.<sup>†</sup> A similar extension is feasible for continuous multidimensional systems.

e. Impulse Response Test

The discussions of III-D-e can be readily generalized from the two-dimensional to multidimensional digital filters. Indeed, Strinzis [64] has obtained such a generalization. For stability test, it appears that the following theorem which is a generalization of Theorem 12 is of importance and could be useful for stability checking:

<sup>†</sup>Very recently in as yet unpublished article, the solution to this problem is given by N. K. Bose.

Theorem 25 [64]. Let  $\{g_{k_1, k_2, \dots, k_n}\}$  be the sequence obtained by the multidimensional generalization of the recursive relationships in (93-95). The following condition is necessary and sufficient for BIBO stability of  $G(z_1, z_2, \dots, z_n)$  (i.e. generalization of (1) in theorem 12).

$$\overline{\text{Lim}} |g_{k_1, k_2, \dots, k_n}|^{\frac{1}{k_1 + k_2 + \dots + k_n}} < 1 \quad (140)$$

for all but a finite number of values of  $(k_1, k_2, \dots, k_n)$ .

The other theorems presented for the two-dimensional case can be readily generalized.

#### f. Cepstral Stability Test [93]

In this work Ahmadi and King [93] have extended the Pistor method discussed in (III-D-f) to the multidimensional cepstral method. In this case they defined the multidimensional z-transform of the cepstrum  $\hat{G}(z_1, z_2, \dots, z_n)$  as the logarithm of the multidimensional z-transform of an array  $g(m, n, k, \dots, \ell) \in \ell_1$ :

$$\hat{G}(z_1, z_2, \dots, z_n) = \ell_n [Z\{g(m, n, k, \dots, \ell)\}] = \ell_n G(z_1, z_2, \dots, z_n) \quad (141)$$

Based on the above, the authors generalized the stability theorem of Pistor [31] to give:

Theorem 26 [93]. The sequence

$${}^1 q(m, n, k, \dots, \ell) ; m \geq 0, n \geq 0, \dots, \ell \geq 0 \quad (142)$$

is recursively stable if and only if there exists a power series

$$\sum_{m=0}^{\infty} \sum_{n=0}^{\infty} \cdots \sum_{\ell=0}^{\infty} {}^1\hat{q}(m,n,k,\dots,\ell) z_1^m z_2^n z_3^k \cdots z_r^\ell \quad (143)$$

that is absolutely convergent and equal to  $\ln Q(z_1, \dots, z_n)$  for all  $z_i$  such that  $\bigcap_{i=1}^n |z_i| \leq 1$  (where  ${}^1q(m,n,k,\dots,\ell)$  is the first quadrant sequence and  $\{\hat{q}(m,n,k,\dots,\ell)\}$  is the inverse z-transform of  $\hat{Q}(z_1, z_2, \dots, z_n)$ , i.e.

$$\{{}^1\hat{q}(m,n,k,\dots,\ell)\} \leftrightarrow \hat{Q}(z_1, z_2, \dots, z_n) = \ln Q(z_1, \dots, z_n) \quad (144)$$

In the above  $Q(z_1, z_2, \dots, z_n)$  represents the denominator of the causal filter

$$F(z_1, z_2, \dots, z_n) = \frac{1}{Q(z_1, z_2, \dots, z_n)} \quad (145)$$

A similar generalization can be obtained for each of the other  $2^n$  quadrant functions  ${}^bq$ , in which  $b = 2, 3, \dots, 2^n$ . Similar to Pistor [31] the authors of this generalization have not presented an algorithm for checking stability. It remains to generalize Ekstrom and Twogood's [69] algorithm for the multidimensional case. In the paper by Ahmadi and King [93], the authors showed how an unstable multidimensional recursive digital filter can be decomposed into  $2^n$  stable recursive filters. The number of dimensions in this case is "n".

#### g. Nyquist-Like Tests [45,72]

The generalization of the theorems given earlier for the two-dimensional case to the multidimensional case is straightforward and was obtained by DeCarlo, Murray and Saeks [47,75] using the concept of homotopy. These three theorems are presented below:

Theorem 27 [45,72]. The multidimensional filter described in equation

(116) is structurally stable if and only if

- (i)  $Q(z_1, z_2, \dots, z_n)$  has no zeros on  $\bigcap_{i=1}^n |z_i| = 1$   
(ii) The Nyquist plots for the one-dimensional function

$$Q(1, \dots, 1, z_k, 0, \dots, 0), \quad k = 1, 2, \dots, n$$

do not encircle zero.

Theorem 28 [45,72]. Let  $Q$  be as in equation (116). The filter is structurally stable if and only if

- (i)  $Q(z_1, z_2, \dots, z_n)$  have no zeros in  $\bigcap_{i=1}^n |z_i| = 1$   
(ii) The Nyquist plots for the one-dimensional function

$$Q(1, \dots, 1, z_k, 1, \dots, 1), \quad k = 1, 2, \dots, n$$

do not encircle zero.

Theorem 29 [45,72]. Let  $Q$  be described as in equation (116). The filter is structurally stable if and only if

- (i)  $Q(z_1, z_2, \dots, z_n) \neq 0$  for  $\bigcap_{i=1}^n |z_i| = 1$   
(ii) The Nyquist plot for the one-dimensional function

$$Q(z_1, z_2, \dots, z_n), \quad z_1 = z_2 = \dots = z_n = z$$

does not encircle zero.

Remark

From the earlier theorems, it is evident that the difficult part of the test is that  $Q$  should have no zeros on the distinguished boundary of the unit polydisc. To do this by plotting the image of the distinguished boundary

---

<sup>†</sup>Items (ii) of Theorems 27 and 28 can be obtained as a special case of the following:

$$Q(b_1, \dots, b_{k-1}, z_k, a_1, \dots, a_r) \neq 0, \quad \text{when } |z_k| \leq 1, \quad k = 1, 2, \dots, n, \quad \text{and } |b_r| = 1, \\ |a_r| \leq 1$$



is extremely difficult for  $n > 2$ . So far, the authors have not come up with a straightforward procedure for performing this test. However, for the case  $n = 2$ , this method is simple and of much importance. Furthermore, as mentioned in the earlier discussion for the two-dimensional case, this method can be extended to multidimensional continuous systems and to other regions of analyticity.

#### h. Direct Methods of Stability Tests [85,86,94-96]

From the earlier discussions, it is apparent that in the stability tests for the various analytic regions one has to check either global positivity, nonnegativity or local positivity and nonnegativity. One such method which tackles these tests as mentioned before was based on the inners concept as advanced by Bose and coworkers. Based on the equivalence of inners determinants and minors of half-size matrices as discussed in (II), the symmetric matrix approach can be similarly applied. The tests for positivity and nonnegativity are important not only for checking multidimensional stability, but also appear as crucial tests in many other applications such as in Lyapunov Theory, in Limit Cycles existence, in the output feedback problems, in multivariable positive real tests and in a host of other problems. Their study has attracted much activity.

In addition to the inners approach, there exist two other approaches. The first is based upon an augmented theory of resultants and resultants with back substitution and factorization as expressed within the framework of algebraic geometry as discussed by Anderson-Scott [85] and Scott [86]. An extension and elaboration of this method is advanced by Bickart-Jury [94,95]. An algorithm is given for the various tests. The second approach is proposed by Gesing and Davison [96]. Their approach is based on

a minimization procedure for a resolution on a hypercube of  $\mathbb{R}^n$  of the positivity and nonnegativity. In the study of Bickart-Jury [94], a comparative study of the three methods is attempted and in the following table, we present the summary of the results.

Method	Sufficient	Necessary	Exact Arithmetic	Dimension Growth	Special Case	Localization
Resultant	yes	no	yes	yes	no	global
Resultant with back substitution, factorization	yes	yes	no	yes	no	global non-global
Decision algebra (inners)	yes	yes	yes	no (positivity) yes (nonnegativity)	yes	global non-global local
Minimization	yes	yes	no	no	no	local

Table 2. Properties and methods for resolving positivity and nonnegativity.

## V. Brief Review of One-Dimensional Stability (Matrix Case)

In this section, we present the various tests for stability of one-dimensional polynomial matrices. The study of such matrices arise in the multi-input-multi output (MIMO) system (open loop and feedback). These systems are also known in the literature as multivariable systems. Their study has been the center of major research activities in the past two decades. The texts of Rosenbrock [97], Wolovich [98] and Desoer-Vidyasagar [99] are only but a few of the extensive publications in this important field.

In the review of the stability tests, we will divide the methods into analytical and graphical (or Nyquist-Like Tests). The applications of these methods to the stability of two- and multidimensional polynomial matrices to be discussed in the next sections will be emphasized. In particular, the differences between the stability of the one-dimensional and multidimensional polynomial matrices will be singled out. Finally, it should be mentioned that the stability tests introduced in sections (II-IV) will play a major role in this and the next two sections, thus providing a unification of the various methods for all the six sections.

### A. Analytical Tests

To mention the various analytic tests, it is pertinent to present the mathematical description of (MIMO) systems. These are presented (for the continuous case) in time domains as

$$\begin{aligned}\dot{\underline{x}}(t) &= \underline{A}\underline{x}(t) + \underline{B}\underline{u}(t) \\ \underline{y}(t) &= \underline{C}\underline{x}(t) + \underline{D}\underline{u}(t)\end{aligned}\tag{149}$$

or in terms of the transfer function as follows:

$$G(s) = C(sI - A^{-1})B + D \quad (150)$$

In other situations it is presented in terms of a system matrix as defined by Rosenbrock [97]. In this case the system matrix is

$$P(s) = \begin{bmatrix} sI - A & -B \\ C & D \end{bmatrix} \quad (151)$$

Without going into the details of each of these descriptions, we will introduce the following stability tests.

a. Lyapunov Test

If the system is presented by the state space equation (149), then one can determine "BIBO" stability from the A-matrix. One such method is based on Lyapunov's method. Since we are dealing with linear time-invariant systems, Lyapunov stability and "BIBO" stability are one and the same. Also, from the A-matrix, one can obtain the characteristic polynomial which needs to be Hurwitz for stability. Thus one can apply any of the classical stability tests on the characteristic polynomials. Other methods are available for testing the stability of the A-matrix. For discussion of such methods and Lyapunov's tests, we refer to Jury [23]. Also in this reference the stability of the A-matrix inside the unit disc is discussed which relates to the stability of the state-space difference equation description.

b. Determinant Test

This method is based on testing the stability of a polynomial for its Hurwitz character. It is based on the following considerations.

The matrix  $G(s)$  (bounded at  $s = \infty$ ) in equation (150) can be factored as

$$G(s) = N(s)D^{-1}(s) \quad (152)$$

where

(1)  $N(s)$  and  $D(s)$  are  $n \times n$  matrices whose elements are polynomials in  $s$ .

(2)  $N(s)$  and  $D(s)$  are right coprime. (153)

(3)  $\det D(s) \neq 0$

(4)  $s$  is a pole of  $G(s)$  if and only if it is a zero of  $\det D(s)$ .

Based on the above facts, one can determine the stability of  $G(s)$  by examining the Hurwitz character of the determinant of  $D(s)$ . Hence it is called the determinant method. For definitions and algorithms for the factorization, see MacDuffie [100] and Rosenbrock [97]. For items (3) and (4), we refer the reader to Bourbaki [101], Popov [102], Rosenbrock [97], Wang [103] and Wolovich [104]. It appears that the above test is due to many authors and none can claim priority for all the above considerations.

Remark. The above stability test is very important for its extension to two- and multidimensional polynomial matrices and will be the major topic of the next sections. Extension of this method to the feedback case was formulated by Desoer-Schulman [105].

### c. Nondeterminant Test

This method due to Anderson-Bitmead [106] who considered the following test: Given a square, non-singular polynomial matrix  $D(s)$ , how does one test, without evaluating the determinant, whether all the zeros of  $D(s)$  in equation (152) are in the open-left half-plane?

The approach of this test is to derive from  $D(s)$  a rational transfer function matrix which is lossless positive real (l.p.r.) if and only if  $\det D(s)$  is Hurwitz. The (l.p.r.) property is easily checked using the coefficients of the rational function only. This checking involves the use of a generalized Bézoutian matrix whose connection with the generalized Sylvester matrix was discussed by Anderson-Jury [29a]. In this method, the construction of the (l.p.r.) function requires solution of a polynomial matrix equation. Up to this writing, this method seems computationally more involved than the preceding one. However, future research on this problem might lead to simpler results.

If one restricts the class of polynomial matrices, then Shieh and Sacheti [107] have shown how to use a form of the Routh table to test stability. The restriction involves both the odd and even parts of the matrix polynomial be symmetric.

d. Matrix Entries Test<sup>†</sup>

In this case a "MIMO" one-dimensional linear system whose transfer function  $G(s)$  given in equation (150) is BIBO stable if and only if each entry of  $G(s)$  corresponds to a single-input-single-output system which is BIBO stable. We can apply the known tests to each of the entries of  $G(s)$ . Of course, in certain cases this involves formidable computations.

e. Diagonal Dominance Test

This test which was developed by Rosenbrock [97] and based on a diagonal dominance condition of a polynomial matrix as discussed by Ostrowski [108] is a very powerful test for "MIMO" stability. The condition for diagonal dominance is based on the following definition:

---

<sup>†</sup>C. T. Chen, Introduction to Linear System Theory, Holt, Rinehart and Winston, Inc., 1970, Th. 8-5, p. 322.

Definition. A matrix  $D(s)$  is a diagonally dominant on  $\text{Re } s \geq 0$  if

(a)  $d_{ii}(s)$  has no "poles" on  $\text{Re } s \geq 0$ ,  $i = 1, 2, \dots, n$

and (b) for all  $s: \text{Re } s \geq 0$

$$|d_{ii}(s)| > \begin{cases} \text{either } \sum_{j \neq i} d_{ij}(s), & i = 1, 2, \dots, n \\ \text{or } \sum_{j \neq i} d_{ji}(s), & i = 1, 2, \dots, n \end{cases} \quad (154)$$

If the above condition is satisfied, then one can check stability by testing only the diagonal terms of the matrix  $D(s)$ . This represents a significant simplification.

#### B. Graphical Tests

In examining the form of equation (153) based on the determinant method, it becomes evident that one can apply the Nyquist criterion for testing the Hurwitz character of  $\det D(s) = 0$ . The idea of expressing stability conditions in terms of the Nyquist plots of the eigenvalues of  $G(s)$  was originated by MacFarlane [109]. This work was followed by him and his coworkers in a series of papers. The latest by MacFarlane and Postlethwaite [110] generalizes this method to obtain the characteristic frequency and characteristic gain functions. A comprehensive study of the "MIMO" stability based on the eigenvalues of  $G(s)$  was presented by Barman and Katzenelson [111]. Several important theorems were presented in this work. It is of interest to note that in both MacFarlane's and Barman-Katzenelson's works, problems associated with algebraic functions of two dimensions are explored. The advantage of the eigenvalue design lies in the fact that it provides the designer with the insight which enables him to choose a

compensater. This was effectively demonstrated by MacFarlane and his coworkers in several important papers.

Another major contribution to applications of Nyquist diagrams to "MIMO" stability was obtained by Rosenbrock [97]. In this work the author utilized the concept of diagonal dominance of the matrix  $D(s)$  to test stability by using the Nyquist plot. In this case, Rosenbrock combined graphically the test of diagonal dominance and Nyquist tests by plotting the Gershgorin's bands on the Nyquist locus. In the next section we will extend this method for checking graphically the two-dimensional "MIMO" stability. As mentioned earlier the diagonal dominance condition of  $D(s)$  considerably simplifies the stability test. The Gershgorin's bands are a graphical method for testing diagonal dominance.

Recent work by Saeks [112] and DeCarlo and Saeks [113] has demonstrated the power of the Nyquist-like tests. In this work the authors utilized concepts from algebraic topology such as homotopy theory to construct new proofs of the Nyquist criteria. This work is of significant value for it shows the general applications of the Nyquist-Like test to many cases, in particular the two-dimensional case discussed earlier. In extending their results to "MIMO" stability, they proved the following theorem:

Theorem 30 [113]. The system described by  $G(s)$  in equation (152) is stable if and only if the Nyquist plot of  $\det D(s)$  does not encircle nor pass through "0" in the complex plane. For applying this theorem conditions (1) and (2) of equation (153) should be satisfied.

Other major applications of the Nyquist-Like tests are discussed in detail by the Desoer-Vidyasagar text [99].



Remarks

1. Though the above tests are discussed for open left half plane stability (continuous systems), they are also extended to stability within the unit circle (discrete systems). The latter form will play a major role in the discussions that will follow.

2. Since DeCarlo and Saeks [113] are mainly interested in an answer only to stability, their method seems simpler than that of MacFarlane or Barman-Katzenelson's methods. Furthermore, it seems that the latter method has not yet been extended to two- and multidimensional systems. Hence, comparison with the former methods of DeCarlo-Saeks and Rosenbrock is premature.

## VI. Stability of Two-Dimensional Polynomials (Matrix Case)

In this section, we will present stability tests for two-dimensional polynomial matrices. These matrices arise in the multi-input-multi-output two-dimensional digital filters. To obtain these matrices, it is useful to describe the 2-D filter in the state-space representation.<sup>†</sup> The stability tests which we will present are analytical as well as graphical based on the Nyquist-like tests. These tests are generalizations of what we described in section V.

In the past several years, different state-space representations were formulated for the two-dimensional recursive filters which are causal and of first quadrant types. Among such representations are those of Attasi [114], Fornasini and Marchesini [115] and Roesser [116]. Without going into detail of advantages and disadvantages of each model of representation, we only mention that relying on the definitive and noteworthy contributions of Kung et al [117] and Morf et al [118], we will present our discussions based on the Roesser model. Morf et al have argued in favor of Roesser's model for it represents a truly first order system,<sup>††</sup> while the other models do not. They have shown the merits of Roesser's model in their exhaustive discussions of the properties of multi-input, multi-output two-dimensional systems. For other informative discussions of the models mentioned above as well as other important items, we refer the reader to the work of Willsky [119]. Before we present Roesser's model, we might mention that some of the stability tests are also applicable to the other models with some modifications. Whenever appropriate we will also mention some of the stability tests related to the other models.

---

<sup>†</sup> They can also be obtained from the matrix transfer function.

<sup>††</sup> That is, R and S in equation (155) together comprise a valid local state.

Formulation of Roesser's Model [116]. In the following formulation,  $i, j$  are integer valued vertical and horizontal coordinates,  $\{R\} \in \mathbb{R}^{n_1}$ ,  $\{S\} \in \mathbb{R}^{n_2}$  are sets which convey information vertically and horizontally, respectively. The input and output of the system are  $\{u\} \in \mathbb{R}^p$ ,  $\{y\} \in \mathbb{R}^n$ . The system to be considered is discrete, causal, and its state and output functions are described by:

$$\begin{aligned} R(i+1, j) &= A_1 R(i, j) + A_2 S(i, j) + B_1 u(i, j) \\ S(i, j+1) &= A_3 R(i, j) + A_4 S(i, j) + B_2 u(i, j) \\ y(i, j) &= C_1 R(i, j) + C_2 S(i, j) + D_4 u(i, j) \end{aligned} \quad (155)$$

We apply the two-dimensional z-transform to the above equation and assuming zero initial conditions, we obtain:

$$y(z_1, z_2) = \{[C_1, C_2] \begin{bmatrix} z_1^{-1} I_{n_1} & -A_1 & & \\ & -A_3 & & \\ & & z_2^{-1} I_{n_2} & -A_4 \\ & & & -A_2 \end{bmatrix}^{-1} \begin{bmatrix} B_1 \\ B_2 \end{bmatrix} + D\} \hat{u}(z_1, z_2) \quad (156)$$

or

$$G(z_1, z_2) = [C_1, C_2] \begin{bmatrix} z_1^{-1} I_{n_1} & -A_1 & & \\ & -A_3 & & \\ & & z_2^{-1} I_{n_2} & -A_4 \\ & & & -A_2 \end{bmatrix}^{-1} \begin{bmatrix} B_1 \\ B_2 \end{bmatrix} + D \quad (157)$$

where  $G(z_1, z_2)$  is the two-dimensional transfer function. It is described by a two-dimensional polynomial matrix. It is the two-dimensional discrete counterpart of equation (150).

### Remarks

1. The computation of the square bracketed term in equation (157) is often required and for this Koo and Chen [120] have obtained an efficient algorithm to compute the characteristic polynomial based on extending the 1-D Fadeeva algorithm.<sup>†</sup> After obtaining the characteristic polynomial, the stability tests of (III-D) are readily applicable. Such a test was performed by Barry, et al. [125].

<sup>†</sup>See also [120a].

2. The models of Fornasini and Marchesini [115] as well as of Attasi [114] are represented respectively as follows:

$$\begin{aligned}x(m+1, n+1) &= A_0 x(m, n) + A_1 x(m+1, n) + A_2 x(m, n+1) + Bu(m, n) \\y(m, n) &= Cx(m, n)\end{aligned}\tag{158}$$

and

$$\begin{aligned}x(m+1, n+1) &= F_1 x(m, n+1) + F_2 x(m+1, n) - F_1 F_2 x(m, n) + Gu(m, n) \\y(m, n) &= Hx(m, n)\end{aligned}\tag{159}$$

where it is assumed that

$$F_1 F_2 = F_2 F_1\tag{160}$$

is a separable 2-D system. It is noted that Attasi's model is a special case of equation (158). Since it is separable, many of the one-dimensional concepts and results are readily extended to this system, in particular, the stability tests mentioned in the preceding section.

BIBO Stability. We will define the concept of "BIBO" stability for the system described by equation (155). The following theorems follow from the work of Humes-Jury [37].

Theorem 31 [37]. A "MIMO" 2-D linear system described by equation (155) is "BIBO" stable if and only if there exists a real  $\gamma < \infty$  such that for all positive integers  $m, n$

$$\sum_{k=0}^m \sum_{\ell=0}^n \|G(k, \ell)\| \leq \gamma < \infty\tag{161}$$

Note:

$$G(k, \ell) = \frac{1}{(2\pi j)^2} \oint_{c_1} \oint_{c_2} G(z_1, z_2) z_1^{-k+1} z_2^{-\ell+1} dz_1 dz_2 \quad (162)$$

where  $c_1$  and  $c_2$  are the boundaries of the unit bidisc.

#### A. Analytic Tests

Theorem 32 [37]. A "MIMO" 2-D linear digital filter whose transfer function is given by the matrix  $G(z_1, z_2)$  in equation (157) is "BIBO" stable if every entry of  $G(z_1, z_2)$  corresponds to a single-input-single-output system which is "BIBO" stable.

##### a. Matrix Entries Test

Theorem 33 [37]. A system whose transfer function is given by (157) is BIBO stable if every entry  $G(z_1, z_2)$  has no 'poles' [note  $(\bar{z}_1, \bar{z}_2)$  is a 'pole' of  $G(z_1, z_2)$  if  $(\bar{z}_1, \bar{z}_2)$  is a zero of the denominator of some entry of  $G(z_1, z_2)$ ] in the region  $\bar{U}^2 = \{(z_1, z_2): |z_1| \leq 1, |z_2| \leq 1\}$ . On the other hand, if  $G(z_1, z_2)$  is the transfer function of a BIBO stable system, then no entry of  $G(z_1, z_2)$  has poles on  $\bar{U}^2$  or non-essential singularities of the second kind, except possibly on the distinguished boundary  $T^2 = \{(z_1, z_2): |z_1| = |z_2| = 1\}$ . Such cases have been discussed earlier in Section IIIa.1. This method corresponds to the application of 2-D digital filters stability test (discussed in III)  $m \times p$  times. It is the counterpart of the matrix entries test discussed in (V-A.d).

##### b. Determinant Test

In the following the extension of the determinant method discussed in (V-A-b) to the two-dimensional case will be developed. This method is based on the (right or left) decomposition of  $G(z_1, z_2)$  in equation (157)

into two 2-D polynomial matrices  $N(z_1, z_2)$  and  $D(z_1, z_2)$  such that

$$G(z_1, z_2) = N_R(z_1, z_2) D_R^{-1}(z_1, z_2) = D_L^{-1}(z_1, z_2) N_L(z_1, z_2) \quad (163)$$

The pertinent and important results developed by Morf et al [118] on two-dimensional polynomial matrices facilitates the derivation of the determinant test by Humes-Jury [37]. We will present a few facts from Morf et al [118]. The one-dimensional counterpart of these facts can be found in Rosenbrock [97].

Fact 1.  $N(z_1, z_2)$ ,  $D(z_1, z_2)$  are two-dimensional right coprime (left coprime) if

(i)  $N$ ,  $D$  are one-dimensional right (left) coprime as polynomials in  $z_1$  with coefficients that are rational functions of  $z_2$ ;

(ii)  $N$ ,  $D$  are one-dimensional right (left) coprime as polynomial matrices in  $z_2$  with coefficients that are rational functions in  $z_1$ .

Fact 2. Let  $N(z_1, z_2)$  be a full rank two-dimensional polynomial matrix. Then there exists a unique  $\bar{N}(z_1, z_2)$  (modulo a right unimodular matrix) and a unique  $N^*(z_1, z_2)$  (modulo a left unimodular matrix) with

$$\det \bar{N}(z_1, z_2) = \bar{n}(z_2) \quad (164)$$

and  $N^*(z_1, z_2)$  primitive<sup>†</sup> such that

$$N(z_1, z_2) = \bar{N}(z_1, z_2) N^*(z_1, z_2) \quad (165)$$

Furthermore, Morf et al [118] gave an algorithm that gives the GCRD (greatest common right divisor) of  $N(z_1, z_2)$  and  $D(z_1, z_2)$ . It is based on obtaining the primitive factorization on the right hand side of  $N$  and  $D$ , i.e. find  $N^*$ ,  $D^*$  and  $R_0$  such that

<sup>†</sup>By primitive we mean the following:

Let  $A(z, \omega)$  be a  $m \times n$  polynomial matrix, ( $m \leq n$ ), then  $A(z, \omega)$  is said to be primitive in  $F[\omega][z]$  (the ring of polynomials in  $z$  with coefficients in  $F[\omega]$ ) iff  $A(z, \omega_0)$  is of full rank for all fixed  $\omega_0$ .

$$\begin{bmatrix} N \\ D \end{bmatrix} = \begin{bmatrix} N^* \\ D^* \end{bmatrix}_{R_0} \quad (166)$$

with  $\begin{bmatrix} N^* \\ D^* \end{bmatrix}$  primitive.

Fact 3. If  $G(z_1, z_2) = N_R(z_1, z_2)D_R^{-1}(z_1, z_2) = D_\ell^{-1}(z_1, z_2)N_\ell(z_1, z_2)$  with  $N_R, D_R$  two-dimensional right coprime and  $N_\ell, D_\ell$  are two-dimensional left coprime, then

$$\det D_R(z_1, z_2) = \det D_\ell(z_1, z_2) \quad (167)$$

Considering the above facts and assuming we have the right coprime factorization of  $G(z_1, z_2)$ , i.e.

$$G(z_1, z_2) = N_R(z_1, z_2)D_R^{-1}(z_1, z_2) \quad (168)$$

the following theorems present useful procedures for testing BIBO stability as proven by Humes-Jury [37].

Theorem 34 [37]. The pair  $(\bar{z}_1, \bar{z}_2)$  is a 'pole' of  $G(z_1, z_2)$  if and only if  $(\bar{z}_1, \bar{z}_2)$  is a zero of  $\det D_R(z_1, z_2)$ .

Theorem 35 [37]. Let  $G(z_1, z_2)$  be the transfer function of a two-dimensional "MIMO" digital filter written in one of the following forms:

$$\begin{aligned} G(z_1, z_2) &= N_R(z_1, z_2)D_R^{-1}(z_1, z_2) \quad \text{with } N_R, D_R \text{ 2-D R-coprime} \\ \text{or} & \\ G(z_1, z_2) &= D_\ell^{-1}(z_1, z_2)N_\ell(z_1, z_2) \quad \text{with } N_\ell, D_\ell \text{ 2-D } \ell\text{-coprime} \end{aligned} \quad (169)$$

If  $\det D_\ell(z_1, z_2) = \det D_R(z_1, z_2)$  has no zeros inside the unit bidisc  $\bar{U}^2 = \{z_1, z_2: |z_1| \leq 1, |z_2| \leq 1\}$  then the system is BIBO stable. On the other hand if  $G(z_1, z_2)$  is the transfer function of a BIBO stable system, then  $\det D(z_1, z_2)$  has zeros in  $\bar{U}^2$  and  $G(z_1, z_2)$  has no non-essential

singularities of the second kind on  $\bar{U}^2$  except possibly on  $T^2 = \{z_1, z_2: |z_1| = |z_2| = 1\}$ . In this case the non-essential singularity of the second kind must occur in all entries of the matrix

$$G(z_1, z_2) = \frac{N(z_1, z_2) \text{adj } D(z_1, z_2)}{\det D(z_1, z_2)} \quad (170)$$

### Remarks

1. To determine if  $\det D_Q(z_1, z_2) = \det D_R(z_1, z_2)$  has no zeros on the unit bidisc  $\bar{U}^2$ , we can invoke any of the stability tests for two-dimensional polynomials (scalar case) discussed in (III).

2. From now henceforth, we assume that the critical case of singularities of the second kind on the boundary of the bidisc is avoided, as we did for the two-dimensional scalar case, and therefore we refer the reader to the necessary and sufficient condition of "BIBO" stability as structural stability.

### c. Lyapunov Test

This test was developed by Piekarski [121] for the  $n$ -dimensional matrix case for both continuous and discrete forms. In the following we will present only the two-dimensional version of this test and in the next section the general form will be presented.

Two-Dimensional Discrete Case. Suppose  $g(z_1, z_2) = \det \begin{pmatrix} \Lambda & -A \\ n_2 & n_2 \end{pmatrix}$  is a two-dimensional characteristic polynomial of an arbitrary  $n_2 \times n_2$  complex matrix  $A_{n_2}$ , where  $A_{n_2} = z_1 I_{m_1} \dot{+} z_2 I_{m_2}$  is an  $n_2 \times n_2$  diagonal matrix with diagonal complex variables  $z_1, z_2$ , where  $\dot{+}$  denotes the direct sum of matrices. The following theorem follows:



Theorem 36 [121]. The necessary and sufficient condition that the two-dimensional characteristic polynomial  $g(z_1, z_2)$  have all its eigenvalues inside the unit bidisc if and only if there exists a positive definite Hermitian matrix

$$W_{n_2} = W_{m_1} + W_{m_2} > 0, \text{ with } (W_{m_i} = W_{m_i}^*), i = 1, 2 \quad (171)$$

such that

$$A_{n_2}^* W_{n_2} A_{n_2} - W_{n_2} < 0 \quad (172)$$

Two-Dimensional Continuous Case. The two-dimensional characteristic polynomial  $g_1(s_1, s_2) = \det(\Lambda_{n_2} - A_{n_2})$  is Hurwitzian if and only if there exists a positive definite Hermitian matrix

$$W_{n_2} = W_{m_1} + W_{m_2} > 0, \text{ with } (W_{m_i} = W_{m_i}^*), i = 1, 2 \quad (173)$$

such that

$$W_{n_2} A_{n_2} + A_{n_2}^* W_{n_2} < 0 \quad (174)$$

### Remarks

The application of the Lyapunov tests to Roesser's model is not yet developed. However, Attasi [114] has developed a two-dimensional Lyapunov test for his model. In his case, one simply needs to check the one-dimensional systems along vertical and horizontal lines. This lead to one-dimensional Lyapunov equations which do not constitute any noted new results.

d. Some Necessary and Sufficient Conditions for Stability

In concluding the analytical tests, it is pertinent to mention a useful necessary condition for stability as developed by Alexander and Pruess [122]. It is based on the description of the "MIMO" two-dimensional digital filter whose transfer function is represented by

$$G(m,n) = \bar{B}_1 G_{m-1,n} + \bar{B}_2 G_{m,n-1} + \bar{A} F_{m,n} \quad (175)$$

The above model is a particular case of Fornasini-Marchesini [115] when  $A_0 = 0$  in equation (158). The following theorem follows:

Theorem 37 [123]. The two-dimensional system described by equation (175) is unstable if any one of the spectral radii,  $\rho(\bar{B}_1)$ ,  $\rho(\bar{B}_2)$ ,  $\rho(\bar{B}_1 + \bar{B}_2)$  is greater than or equal to one. Note in this case the two-dimensional z-transform definition of Alexander and Pruess [122] is in terms of negative powers of  $z_1$  and  $z_2$ . Based on this definition, a necessary condition for stability is that all the spectral radii are less than unity.

Remarks:

(1) The spectral radius of the matrix  $\bar{B}$  is defined as the magnitude of the largest magnitude eigenvalue of the matrix  $\bar{B}$ .

(2) It is computationally convenient with the present available methods to compute the spectral radii of matrices. Hence, the above theorem serves as a quick method for checking for instability.

(3) Dr. Alexander in his Ph.D Thesis [122a] had presented some sufficient conditions for (BIBO) stability and, herein, one of these conditions:

The system given by equation (175) is stable if:

$$\zeta [\text{abs}(\bar{B}_1) + \text{abs}(\bar{B}_2)] < 1 \quad (175a)$$

where  $\text{abs}(\bar{B}_1)$  represents the matrix made up of the absolute values of the corresponding elements of the matrix  $\bar{B}$ , i.e.,

$$\text{abs}(\bar{B}) = [ |b_{ji}| ] \quad (175b)$$

(4) In as yet unpublished results by Dr. Humes, a sufficient condition for asymptotic stability for the Roesser model given in equation (55) is obtained. It is given as follows:

A sufficient condition for asymptotic stability of the system given by the first two equations of (155) is given by:

$$\|A_1\| + \|A_4\| - \|A_1\| \|A_4\| + \|A_2\| \|A_3\| < 1 \quad (175c)$$

where  $\|\cdot\|$  represents the norm of the matrix.

It is of interest to note from equation (175c) that for the 1-D matrix case, we obtain

$$\|A\| < 1 \quad (175d)$$

which is both the necessary and sufficient condition for asymptotic stability.

#### B. Graphical Stability Tests [123]

In this test, we will apply the Nyquist-like test discussed in (III-D-g) to the two-dimensional matrix case in connection with the diagonal dominance condition.

From the determinant test discussed earlier, the structural stability is determined by

$$\det D(z_1, z_2) \neq 0, \quad \text{for all } z_1, z_2 \in \bar{U}^2 \quad (176)$$

The objective of the following discussion is to show that if  $D(z_1, z_2)$  is diagonal dominant on the distinguished boundary  $T^2$ , then we can determine stability by applying the Nyquist-like test to the elements of the diagonal of  $D(z_1, z_2)$ .

Diagonal Dominance Conditions [123]. A matrix  $Q(z_1, z_2) \in \mathbb{R}(z_1, z_2)^{n \times n}$  is diagonal dominant on  $T^2$  if

- (a)  $q_{ii}(z_1, z_2)$  has no "poles" on  $T^2$ ,  $i = 1, 2, \dots, n$
- (b) for all  $z_1, z_2 \in T^2$

$$|q_{ii}(z_1, z_2)| > \begin{cases} \text{either } \sum_{j \neq i} q_{ij}(z_1, z_2), & i = 1, 2, \dots, n \\ \text{or } \sum_{j \neq i} q_{ji}(z_1, z_2), & i = 1, 2, \dots, n \end{cases} \quad (177)$$

From the above definition, we arrive at the following theorem by Humes-Jury [123].

Theorem 38 [123]. Let  $G(z_1, z_2) = N(z_1, z_2)D(z_1, z_2)^{-1}$  be the transfer function of a MIMO two-dimensional digital filter, with  $N$  and  $D$  being two-dimensional right coprime. Let  $D(z_1, z_2)$  be diagonal dominant on  $T^2$ . Then  $G(z_1, z_2)$  is structurally stable if and only if the Nyquist-like test of all the diagonal elements of  $D$  ( $d_{ii}(z_1, z_2)$ ,  $i = 1, \dots, n$ ) do not encircle or pass through the origin.

Graphical Construction of Diagonal Dominance [123]. This construction is done by using the parameterization of  $T^2 = \{(e^{j\alpha}, z_2) : |z_2| \leq 1, \alpha \in [0, 2\pi)\}$ . By this procedure for each  $\alpha$  we reduce the problem to a single variable  $z_2$ . Thus the techniques of Rosenbrock [97] discussed in section V can be applied.

Let  $d_{ii}$  map  $\{(e^{j\alpha}, z_2): |z_2| \leq 1, \alpha \in [0, 2\pi)\}$  into  $\Gamma_i(\alpha)$  for each  $i$ . Now consider circles for each  $|z_2|$  such that  $|z_2| = 1$ , with centers at  $d_{ii}(e^{j\alpha}, z_2)$ ,  $i = 1, 2, \dots, n$  and radius given by

$$r_i(\alpha, z_2) = \begin{cases} \text{either } \sum_{j \neq i} d_{ij}(e^{j\alpha}, z_2), & i = 1, 2, \dots, n \\ \text{or } \sum_{j \neq i} d_{ji}(e^{j\alpha}, z_2), & i = 1, 2, \dots, n \end{cases} \quad (178)$$

When  $z_2$  varies along the unit circle, the corresponding circles sweep out a band which can be represented by a finite number of bands. Those bands are called Gershgorin's bands. If for every  $\alpha$  and  $i$ , these bands exclude the origin we readily ascertain that  $D$  is diagonal dominant on  $T^2$ . In checking stability these bands are drawn for each parametrized Nyquist plot, similar to Rosenbrock's [97] construction for the one-dimensional matrix case.

If  $D$  fails to be diagonally dominant on  $T^2$ , we can proceed in either of the following ways:

- (1) Apply the Nyquist-like test to each entry of  $D$ .
- (2) Evaluate  $\det D$  and then apply the Nyquist-like test to it.

### VII. Stability of Multidimensional Polynomials (Matrix Case)

In this section we will generalize the theorems of the preceding section to multidimensional polynomial matrices. Some of the theorems are readily extendable, while others are not. We will discuss some of the difficulties of such extensions in more detail.

If we have  $n$  spatial dimensions, we can generalize Roesser's model [116,116a] to the following:

$$\begin{aligned}
 R_i(k_1, k_2, \dots, k_n) &= [A_{i,1} \cdots A_{i,n}] \begin{bmatrix} R_1(k_1, \dots, k_n) \\ \vdots \\ R_n(k_1, \dots, k_n) \end{bmatrix} + \begin{bmatrix} B_1 \\ \vdots \\ B_n \end{bmatrix} u(k_1, \dots, k_n) \\
 y(k_1, \dots, k_n) &= [C_1 \cdots C_n] \begin{bmatrix} R_1(k_1, \dots, k_n) \\ \vdots \\ R_n(k_1, \dots, k_n) \end{bmatrix} + Du(k_1, \dots, k_n)
 \end{aligned} \tag{179}$$

for  $i = 1, \dots, n$ , each  $A_{ij}$  is a matrix of dimension  $n_i \times n_j$  ( $j = 1, \dots, n$ ),  $B_i$ ,  $C_i$  are matrices of dimension  $n_i \times p$  and  $m \times n_i$ , respectively, and  $D$  is of dimension  $m \times p$ .

By applying the  $n$ -dimensional  $z$ -transform to equation (179), we obtain the  $n$ -dimensional transfer function (corresponding to equation (157)),

$$G(z_1, z_2, \dots, z_n) = [C_1, \dots, C_n] \begin{bmatrix} (z_1^{-1} I_{n_1} - A_{11}) - A_{22} - \cdots - A_{1n} \\ -A_{21} (z_2^{-1} I_{n_2} - A_{22}) - \cdots - A_{2n} \\ \vdots \\ -A_{n1} - A_{n2} - \cdots - (z_n^{-1} I_{n_n} - A_{nn}) \end{bmatrix}^{-1} \begin{bmatrix} B_1 \\ B_2 \\ \vdots \\ B_n \end{bmatrix} + D \tag{180}$$

Extending the stability theorems of the preceding section, we obtain following Humes-Jury [37] the following:

Theorem 39 [37]. A "MIMO" n-dimensional linear system described by equation (179) is "BIBO" stable if and only if there exists a real  $\gamma < \infty$  such that for all positive integers  $(m, n, \dots, r)$

$$\sum_{k=0}^m \sum_{\ell=0}^n \cdots \sum_{s=0}^r \|G(k, \ell, \dots, s)\| \leq \gamma < \infty \quad (181)$$

where  $G(k, \ell, \dots, s)$  is obtained in a similar but generalized form as equation (162).

Theorem 40 [37]. A "MIMO" n-dimensional linear digital system whose transfer function is given by the matrix  $G(z_1, \dots, z_n)$  is BIBO stable if and only if each entry of  $G(z_1, \dots, z_n)$  corresponds to a single-input-single-output system which is BIBO stable.

Theorem 41 [37]. A system whose transfer function is given by equation (180) is BIBO stable if every entry of  $G(z_1, \dots, z_n)$  has no 'poles' in the region  $\bar{U}^n = \{(z_1, \dots, z_n) : |z_1| \leq 1, |z_2| \leq 1, \dots, |z_n| \leq 1\}$ . On the other hand if  $G(z_1, \dots, z_n)$  is the transfer function of a BIBO stable system, then no entry of  $G(z_1, \dots, z_n)$  has poles on  $\bar{U}^n$  or non-essential singularities of the second kind, except possibly on the distinguished boundary of  $\bar{U}^n$  (i.e. when  $|z_1| = |z_2| = \dots = |z_n| = 1$ ).

Remark. Similar to the two-dimensional discussions, we will ignore this type of singularity and we refer to "BIBO" stability as structural stability. Thus the above theorem will give the necessary and sufficient condition for structural stability.

To generalize the determinant method discussed in VI-A-b, we will first present the following definitions.

Definition [118]. The  $n$ -dimensional polynomial matrices  $N$  and  $D$  are  $n$ -dimensional right coprime if and only if  $N$  and  $D$  are one-dimensional right coprime in

$$\mathbb{R}[z_i](z_1, z_2, \dots, z_{i-1}, z_{i+1}, \dots, z_n), \quad \text{for } i = 1, 2, \dots, n \quad (182)^\dagger$$

The following theorems were developed by Humes-Jury [124] as a generalization of the two-dimensional case.

Theorem 42 [124]. Given an  $n$ -dimensional rational matrix  $G(z_1, \dots, z_n)$ , suppose

$$G(z_1, \dots, z_n) = N_R(z_1, \dots, z_n) D_R(z_1, \dots, z_n)^{-1} = D_\ell(z_1, \dots, z_n)^{-1} N_\ell(z_1, \dots, z_n)$$

where  $N_R, D_R$  are  $n$ -dimensional right coprime  $n$ -dimensional polynomial matrices and  $N_\ell, D_\ell$  are  $n$ -dimensional left coprime  $n$ -dimensional polynomial matrices. Then

$$\det D_R = \det D_\ell \pmod{\text{constant}} \quad (183)$$

Theorem 43 [124]. Let  $G = ND^{-1}$  where  $G \in \mathbb{R}(z_1, \dots, z_n)^{p \times q}$ ,  $N \in \mathbb{R}[z_1, \dots, z_n]^{p \times q}$  and  $D \in \mathbb{R}[z_1, \dots, z_n]^{q \times q}$ . Furthermore assume  $N$  and  $D$  are  $n$ -dimensional right coprime. Then

$$(\bar{z}_1, \dots, \bar{z}_n) \in \mathbb{C}^n \text{ is a zero of } \det D \Leftrightarrow (\bar{z}_1, \dots, \bar{z}_n) \in \mathbb{C}^n$$

is a non-essential singularity of  $G$ .

Note.  $(\bar{z}_1, \dots, \bar{z}_n)$  is a non-essential singularity of  $G$  if  $(\bar{z}_1, \dots, \bar{z}_n)$  is a zero of the denominator of some entry of  $G$ .

---

<sup>†</sup>D. Youla with G. Gnani in a recent work entitled, "Notes on  $n$ -dimensional System Theory," to be published, has introduced three definitions of coprimeness different than the above.



Based on the above theorem and assuming that we are given the  $n$ -dimensional right (or left) coprime factorization of the transfer function of the system  $G = ND^{-1}$ , we can ascertain the necessary and sufficient condition for structural stability by testing the zeros of

$$\det D(z_1, \dots, z_n) = 0 \quad (184)$$

To test the stability of the  $n$ -dimensional scalar polynomial of equation (184), we can apply any of the stability tests discussed in section (IV).

#### Remarks

1. It is shown by a counterexample<sup>†</sup> constructed by D. Youla in as yet unpublished notes that the primitive factorization applicable for the two-dimensional matrix case no longer exists for  $n \geq 3$ . The author is grateful to Dan Youla for supplying him with these unpublished notes.

2. Because of (1), one is not able to obtain the (GCRD) factorization in a similar fashion as for the two-dimensional case. Indeed, the meaning of the (GCRD) factorization for the  $n$ -dimensional case is an open question as well as the existence of an algorithm for obtaining it. This question will be posed as an open research problem in the next section.

3. If the  $n$ -dimensional polynomial matrices  $N$  and  $D$  in  $ND^{-1}$  are not  $n$ -dimensional coprime, then to test stability, we may resort to testing stability of each entry of the  $n$ -dimensional polynomial matrix  $G(z_1, \dots, z_n)$ .

Lyapunov Test [121]. We will present the general  $n$ -dimensional form of the Lyapunov test as developed by Piekarski [121]. First we present the discrete and then the continuous case.

$n$ -Dimensional Case. Suppose  $g(z_1, z_2, \dots, z_r) = \det[\Lambda_{n_r} - A_{n_r}]$  is a  $n$ -dimensional characteristic polynomial of an arbitrary  $n_r \times n_r$  complex matrix

$A_{n_r}$ , where

$$\Lambda_{n_r} = z_1 I_{m_1} + z_2 I_{m_2} + \dots + z_r I_{m_r} \quad (185)$$

<sup>†</sup>Another counterexample was independently obtained by B. Lévy.

is an  $n_r \times n_r$  diagonal matrix with diagonal complex variables  $z_1, z_2, \dots, z_r$ , where  $\dot{+}$  denotes the direct sum of matrices. The following theorem follows.

Theorem 44 [121]. The necessary and sufficient condition that the  $n$ -dimensional characteristic polynomial  $g(z_1, z_2, \dots, z_r)$  to have all its eigenvalues inside the unit polydisc if and only if there exists a positive definite Hermitian matrix

$$W_{n_r} = W_{m_1} \dot{+} W_{m_2} \dot{+} \dots \dot{+} W_{m_r} > 0 \quad (186)$$

with  $(W_{m_i} = W_{m_i}^*)$ , for  $i = 1, 2, \dots, r$  such that

$$A_{n_r}^* W_{n_r} A_{n_r} - W_{n_r} < 0 \quad (187)$$

Remark. The above theorem is applicable for stability when one uses the classical definition of the  $n$ -dimensional  $z$ -transform (i.e. with negative powers of the  $z_i$ 's).

$n$ -Dimensional Continuous Case [121]. The  $n$ -dimensional characteristic polynomial  $g_1(s_1, s_2, \dots, s_r) = \det(\Lambda_{n_r} - A_{n_r})$  is Hurwitzian if and only if there exists a positive definite Hermitian matrix

$$W_{n_r} = W_{m_1} \dot{+} W_{m_2} \dot{+} \dots \dot{+} W_{m_r} > 0$$

with  $(W_{m_i} = W_{m_i}^*)$ ,  $i = 1, 2, \dots, r$  such that

$$W_{n_r} A_{n_r} + A_{n_r}^* W_{n_r} < 0$$

Remark. Similar to the remark mentioned for the two-dimensional case, the above theorem for the  $n$ -dimensional discrete case was not shown to be applicable for testing stability of Roesser's model or the Fornasini-

Marchesini model either. Hence, the Lyapunov test is not as promising for testing stability as other previously mentioned tests. It is of interest to note that in recent works [125,126], the role of the various state space models is still considered unclear.

### VIII. Conclusions and Recommendation for Future Research

In this paper a comprehensive study of two- and multidimensional systems' stability was presented. In particular the various tests for stability are applied to the various regions of analyticity which classify the particular system. This classification which features one of the main contributions of this paper enables the reader to deal with both continuous-discrete or mixed systems in one unified approach. The complexity of the region of analyticity depends on the stability requirements of the various applications.

It is shown in this paper that the stability tests of two- and multi-dimensional systems reduces to several applications of the stability tests of one-dimensional systems. A comprehensive survey of such tests was published in a companion paper by this author [1]. Hence, the earlier paper and this one present a detailed survey of the stability tests for linear time-invariant one- or many-dimensional systems.

The area of two-dimensional digital filtering is increasing in importance in recent years because of the many applications. A survey of this work as done by Merserau and Dudgeon [22] three years ago included about fifty references. In that survey the stability problem section was only one of several other sections. In the present survey, we mention over a hundred references only to the stability problem and these are by no means exhaustive. This attests to the big strides made in the study of this problem in the past three years. This surge of activity will undoubtedly continue unabated in the years to come. Hence, it is felt that such a survey is timely in order to integrate the widespread volume of publications into a unified theme so that the researcher in this field can find it easy to grasp and evaluate the various tests. It is hoped that this objective of the author will materialize.

In studying the history of the development of stability tests for one-dimensional systems which span over 120 years and the present tests for two- and multidimensional systems which spans about two decades, certain analogies and differences are singled out. In this survey, it is pertinent to remark on them.

1. Both the study of one- and multidimensional stability investigations were motivated by practical applications. For instance Maxwell's work on stability [2] as well as that of Vyschnegradsky in Russia was motivated by the steam engine regulators. The work of Hurwitz at the urging of Stodola was motivated by the stability of turbine engines. Such a historical review was recently presented by the author [59]. Similarly, the stability study of two- and multidimensional systems was motivated by the effective design of two- and multidimensional digital filters and other applications.

2. The early work on stability of one-dimensional systems was done mainly by mathematicians or mathematical physicists. In contrast, the present work on multidimensional stability was done mainly by engineers. This attests to the competence and insight of engineers in the mathematical literature as well as to the solid mathematical education of the engineering curriculae.

3. Most of the early research on one-dimensional stability was done by European and Russian scientists, while the present research performed on multidimensional systems is to a great extent done in the USA. This is due mainly to the generous research support of the National Science Foundation and other governmental agencies to encourage and to give impetus to such study. It is also due to the advanced technology of recent years especially in imagery which motivated the theoretical study connected with these applications. This activity will undoubtedly increase in importance and effort in the coming years.

A major objective of this write-up is to single out some research problems which remain unsolved up to the present time. These are itemized as follows:

1. The study of the significance of the various definitions of coprimeness of N-D matrix polynomials is warranted. Furthermore, the possibility of extracting the common factor (right or left) when the two N-D matrix polynomials are not coprime. This is needed for system theoretic study of N-D matrix case.

2. Extension of the Ekstrom-Twogood [69] cepstral method of testing stability to the multidimensional case. This method was discussed in section III of this survey.

3. Research in obtaining sufficiency conditions for stability for two- and multidimensional systems. This is done in the one-dimensional case and needs to be developed for higher dimensions.

In view of the computational complexity of the stability tests, such conditions are indeed warranted.

4. In the stability tests of one-dimensional systems, it is known that Levinson's algorithm can be used. This is shown by Berkhout [127] and Viera and Kailath [128]. Although the two-dimensional Levinson's algorithm was developed by Justice [129], Lévy et al [126], it has not been extended for stability tests of two-dimensional discrete systems.

5. Extension of the Lyapunov method for stability testing of Roesser's model. This was indicated in the preceding section.

6. A method for testing non-essential singularities of the second kind.<sup>†</sup> Also if such singularities of both numerator and denominator polynomials exist on the unit bidisc (or polydisc), how can one ascertain

---

<sup>†</sup>Such an existence test has been very recently obtained by T. Bickart in a note entitled, "Existence Criterion for Non-Essential Singularities of the Second Kind," to be published.

the stability of the system? This was discussed in section III.

7. In this study the various regions of analyticity were presented because of the various applications. It is of interest to extend these regions to others not yet dictated by the practical applications and to ascertain whether the present tests are still applicable.

8. Extension of the analyticity region of two-dimensional asymmetric (nonanticipative) half-plane digital filters to the multidimensional case.

9. Extension of the Nyquist-like test for the testing of the sign of the multidimensional polynomial on the distinguished boundary on the unit polydisc. This was discussed in sections III and VI.

10. It was mentioned in section III that Shanks' conjecture is false in general. However, it was conjectured by Jury [81] that if the original unstable polynomial and its least-square inverse are of the same degree, then Shanks' conjecture might be valid. So far, no counterexample has been obtained for this conjecture. Hence, it is of interest for effective design to either verify or refute this conjecture and in the same vein, to obtain whatever additional constraints needed to be imposed to verify the conjecture.

11. Extension of the Anderson-Bitmead [106] or Shieh and Sacheti [107] method to the two-dimensional case. These methods were discussed in section V.

12. In this survey, the emphasis of stability tests was on linear time-invariant multidimensional systems. In practice the nonlinear effects of quantization, round-off error, finite arithmetic and others should be taken into account for stability and design. Hence, the extension of the methods presented in this paper to nonlinear and time-varying multidimensional systems is a major

task. For various practical applications, the recent book edited by Oppenheim [130] is a noteworthy contribution.

The above research problems and other mentioned in the text are but a few of the many more which surely exist and are not known to this author. Some of the above problems are difficult and some are straightforward and indeed it would give this author great satisfaction to see the above solved by researchers in our life-time.

I would like to conclude this paper on a personal note. After the publication of my earlier companion paper [1], I received many encouraging and appreciative remarks from many readers, from all over the world. Hence, I would like to take this opportunity to thank them all for their kind remarks. Furthermore, encouraged by these remarks, I embarked on the formidable task of writing this comprehensive paper. Because the area of multidimensional stability has not yet matured as in the one-dimensional case, I have some misgivings about such a write-up. However, I expect that the point of view presented in this paper and the path of investigations proposed will in the long run outweigh these misgivings.

Finally, I wish to convey my sincere thanks to the editorial board of the Proceedings of the IEEE in encouraging me to undertake this task of surveying the field. Needless to say, I was much aided by my students and colleagues in many universities in this write-up and thus, I wish to extend my thanks and appreciation to all of them and in particular to Professors B. D. O. Anderson, N. K. Bose, T. Bickart, T. Kailath and to my students Mrs. Ana Humes and Dr. D. Goodman.



IX. References

- [1] E. I. Jury, "Theory and applications of inners," Proc. IEEE, Vol. 63, pp. 1044-1068, July, 1975.
- [2] J. C. Maxwell, "On Governors," Proc. Royal Society of London, 16, 270-283, 1868. Also printed in Philosophical Magazine, 35 (1868), 385-398.
- [3] H. Ozaki and T. Kasami, "Positive real functions of several variables and their application to variable networks," IRE Trans. on Circuit Theory, CT-7, 251-260, September 1960.
- [4] H. G. Ansell, "On certain two-variable generalizations of circuit theory in the application to networks of transmission lines and lumped reactances," IEEE Trans. on Circuit Theory, CT-11(2), 214-223, June, 1964.
- [5] L. Weinberg, "Approximation and stability-test procedures suitable for digital filters," paper presented at Arden House Workshop on Digital Filtering, Harriman, N.Y., January, 1970.
- [5] Y. Genin, "An algebraic approach to A-stable linear multistep derivative integration formulas," M.B.L.E. Res. Pub., Brussels, Belgium, February 1974.
- [7] T. Bickart and Z. Picel, "High order stiffly stable composite multistep methods for numerical integration of stiff differential equations," BIT 13, 272-285, 1973.
- [8] T. A. Bickart and W. B. Rubin, "Composite multistep methods and stiff stability," in Stiff Differential Systems, R. A. Willoughby, ed., Plenum, New York, 1974.
- [9] E. Hairer and G. Wanner, "Multistep-multiderivation-multistep methods for ordinary differential equations," Computing, 11, 287-303, 1973.

- [10] T. A. Bickart and E. I. Jury, "Arithmetic tests for A-stability, A[ $\alpha$ ] stability and stiff-stability, to be published by BIT, 1978.
- [11] G. A. Bliss, Algebraic Functions, New York: Amer.Math. Society, 1933.
- [12] W. Rudin, Principles of Mathematical Analysis, New York: McGraw-Hill,
- [13] W. F. Osgood, Topics in the Theory of Functions of Several Complex Variables, New York: Dover, 1966.
- [14] R. Narasimham, Several Complex Variables, University of Chicago Press, 1971.
- [15] B. A. Fuks, Introduction fo the Theory of Analytic Functions of Several Complex Variables, Providence AMS, 1963.
- [16] B. A. Fuks, Special Chapters in the Theory of Analytic Function of Several Complex Variables, Providence AMS, 1965.
- [17] M. J. Greenberg, Lectures on Forms in Many Variables, New York: W. A. Benjamin, 1969.
- [18] W. Rudin, Function Theory in Polydisc, New York: W. A. Benjamin, 1969.
- [19] S. Bochner and H. T. Martin, Several Complex Variables, Princeton, N.J.: Princeton University Press, 1948.
- [20] L. Bers, Introduction to Several Complex Variables, New York: Courant Institute of Mathematical Sciences, 1964.
- [21] L. Hörmander, An Introduction to Complex Analysis in Several Variables, Princeton, N.J.: Van Nostrand, 1966.
- [22] R. M. Mersereau and D. E. Dudgeon, "Two-dimensional digital filtering," Proc. IEEE, Vol. 63, pp. 610-623, April, 1975.
- [23] E. I. Jury, Inners and Stability of Dynamic Systems, New York: Wiley Interscience, 1974.

- [24] M. G. Ekstrom and S. K. Mitra, Two-Dimensional Signal Processing, Dowden, Hutchinson and Ross, Publishers, April 1978.
- [25] N. K. Bose, "Problems and progress in multidimensional systems theory," Proc. IEEE, Vol. 65, No. 6, pp. 824-840, June, 1977.
- [26] N. K. Bose (Editor): IEEE Proceedings Special Issue on Multidimensional Systems, Proc. IEEE, Vol. 65, June, 1977.
- [27] E. I. Jury, "Theory and applications of inners: a supplement," Proc. of the 1976 Conf. on Inf. Sci. and Syst., Department of Electrical Engineering, Johns Hopkins University, Baltimore, Md., pp. 1-3, 1976.
- [28] S. Barnett, "Some properties of inners and outers," in Proc. 1976 IEEE Conf. on Decision and Control, Florida, pp. 896-900.
- [29] S. Barnett and E. I. Jury, "Inners and Schur compliment," Linear Algebra, to appear, 1978.
- [29a] B. D. O. Anderson and E. I. Jury, "Generalized Bézoutian and Sylvester matrices in multivariable linear control," IEEE Trans. Auto. Contr., Vol. AC-21, pp. 531-556, 1976.
- [30] T. S. Huang, "Stability of two-dimensional and recursive filters," IEEE Trans. Audio and Electroacoustics, AU-20, 158, 1972.
- [31] P. Pistor, "Stability criteria for recursive filters," IBM Jour. Res. Development, IBM Deutshaland Heidelberg Scientific Center, January, 1974.
- [32] J. H. Justice and J. L. Shanks, "Stability criteria for N-dimensional digital filters," IEEE Trans. Auto. Control, Vol. AC-18, pp. 284-286, June, 1973.
- [33] N. K. Bose, "A criterion to determine if two multivariable polynomials are relatively prime," Proc. IEEE, Vol. 60, No. 1, pp. 134-135, January, 1972.
- [34] N. K. Bose, "An algorithm for GCD extraction from two multivariable polynomials," Proc. IEEE, Vol. 64, No. 1, pp. 185-186, June, 1976.
- [35] C. Farmer and J. B. Bednar, "Stability of spatial digital filters," Math. Biosci., Vol. 14, pp. 113-119, 1972.

- [36] D. Goodman, "Some stability properties of two-dimensional shifts invariant digital filters," IEEE Trans. Circuits and Systems, Vol. CAS-24, pp. 201-208, April 1977.
- [37] A. F. Humes and E. I. Jury, "Stability test for two-dimensional linear multivariable digital filters," Int. J. Control, Vol. 26, No. 2, pp. 225-234, 1977.
- [38] N. K. Bose and R. W. Newcomb, "Tellegen's theorem for multivariable realizability theory," Int. J. Electronics, Vol. 36, pp. 417-425, 1974.
- [39] B. D. O. Anderson, N. K. Bose and E. I. Jury, "Output feedback stabilization and related problems -- Solutions via decision methods," IEEE Trans. Auto. Contr., Vol. AC-20, pp. 53-66, Feb. 1975.
- [40] D. Goodman, "The stability and design of two-dimensional recursive filters," Ph.D. Thesis, Dept. of EECS, University of Calif., Berkeley, Dec. 1977.
- [41] N. K. Pendergrass, "Design and realization of two-dimensional digital filters," Ph.D. Thesis, Dept. of EECS, University of Calif., Berkeley, 1975.
- [42] D. Goodman, "An alternate proof of Huang's stability theorem," IEEE Trans. on ASSP, Vol. ASSP-24, pp. 426-427, Oct. 1976.
- [43] D. L. Davis, "A correct proof of Huang's theorem on stability," IEEE Trans. on ASSP, Vol. ASSP-24, pp. 423-426, Oct. 1976.
- [43a] J. Murray, "Another proof and a sharpening of Huang's theorem," IEEE Trans. on ASSP, Vol. ASSP-25, No. 6, pp. 581-582.
- [44] M. G. "Tests of stability of multidimensional filters," IEEE Trans. on Circuits and Systems, Vol. CAS-24, No. 8, pp. 432-437, Aug. 1977.

- [45] R. A. DeCarlo, J. Murray and R. Saeks, "Multivariable Nyquist theory," Int. J. Control, Vol. 25, No. 5, pp. 657-675.
- [46] D. E. Dudgeon, "Two-dimensional recursive filtering," Sc.D. Thesis, M. I. T., 1974.
- [47] M. P. Ekstrom and J. W. Woods, "Two-dimensional spectral factorization with applications in recursive filtering," IEEE Trans. ASSP, Vol. ASSP-24, pp. 115-128, April 1976.
- [47a] M. P. Ekstrom and J. W. Woods, "Correction to two-dimensional spectral factorization with applications in recursive filtering," IEEE Trans. ASSP, Dec. 1976.
- [48] M. G. Strintzis "Conditions for stability of nonanticipative two-dimensional recursive filters," IEEE Trans. on Auto. Contr., Vol. AC-22, No. 4, pp. 594-597, Aug. 1977.
- [49] J. Murray, "Symmetric half-plane filters," Midwest Circuits and Systems, Aug. 1977.
- [50] S. S. L. Chang, "Stability and realization theory of N-dimensional linear processors and its applications," to appear.
- [51] R. K. Brayton, "Numerical A-stability for difference-differential systems," in Stiff Differential Systems, R. A. Willoughby (ed.), Plenum Press, New York, 1974.
- [52] B. D. O. Anderson and E. I. Jury, "Stability test for two-dimensional recursive filters," IEEE Trans. Audio Electroacoustics, Vol. AU-21, pp. 366-372, Aug. 1972.
- [53] D. D. Šiljak, "Stability criteria for two-variable polynomials," IEEE Trans. Circuits and Systems, Vol. CAS-22, pp. 183-189, March 1975.
- [54] N. K. Bose and S. Basu, "Test for polynomial zeros and polydisc distinguished boundary," to be published.

- [55] N. K. Bose, "Implementation of a new stability test for two-dimensional filters," IEEE Trans. on ASSP, Vol. ASSP-25, pp. 117-120, April 1977.
- [56] N. K. Bose and A. R. Modaresi, "General procedure for multivariable polynomial positivity test with control applications," IEEE Trans. Auto. Contr., Vol. AC-21, pp. 696-701, 1976.
- [57] A. R. Modaresi, "Multivariable polynomial positivity algorithms using inners with applications," Ph.D. Thesis, Dept. of EE, University of Pittsburgh, 1976.
- [58] A. R. Modaresi and N. K. Bose, "On nonglobal positivity and domains of positivity of multivariable polynomials," Proc. IEEE, pp. 936-945, June 1977.
- [59] E. I. Jury, "Routh centennial lecture: Stability tests for one-, two- and multidimensional linear systems," IEE Proc., London, pp. 1237-1240, Dec. 1977.
- [60] A. Cohn, "Über die Anzahl der Wurzeln einer algebraischen Gleichung in einem Kreise," Math. Z., 14-15, pp. 110-148, 1914.
- [61] M. Marden, "Geometry of polynomials," Am. Math. Soc., 2nd ed., 1966.
- [62] E. I. Jury, Theory and application of the z-transform method, Wiley, 1964.
- [63] G. A. Maria and M. M. Fahmy, "On the stability of two-dimensional digital filters," IEEE Trans. on Audio Electroacoustics, Vol. AU-21, pp. 470-472, Oct. 1973.
- [63a] H. W. Schüssler, "A stability theorem for discrete systems," IEEE Trans. ASSP, Vol. ASSP-24, pp. 87-89, Feb. 1976.
- [64] M. G. Strintzis, "BIBO stability of multidimensional filters with rational spectra," IEEE Trans. on ASSP, Vol. ASSP-25, No. 6, pp. 549-553, Dec. 1977.

- [64a] M. G. Strintzis, "On the spatially causal estimation of two-dimensional processes," Proc. IEEE, Vol. 65, No. 6, pp. 979-980, June 1977.
- [65] M. Vidyasagar and N. K. Bose, "Input-output stability of linear systems defined over arbitrary measure space," in Proc. 1975 Midwest Symp. Circuits and Systems, pp. 394-397, Aug. 1975.
- [66] E. V. Krishnamurthy, "A stability test for sampled data systems using matrix power method," Proc. IEEE, pp. 91-92, Jan. 1965.
- [67] A. V. Oppenheim, R. W. Schafer and T. G. Stockham, Jr., "Nonlinear filtering of multiplied and convolved signals," Proc. IEEE, Vol. 56, pp. 1264-1291, Aug. 1966.
- [68] R. Rom, "On the cepstrum of two-dimensional functions," IEEE Trans. on Info. Theory, pp. 214-217, March 1975.
- [69] M. P. Ekstrom and R. E. Twogood, "A stability test for 2-D recursive digital filters using the complex cepstrom," 1977 IEEE Intl. Conf. ASSP, May 9-11, 1977.
- [70] D. E. Dudgeon, "The existence of cepstrom for two-dimensional rational polynomials," IEEE Trans. on ASSP, Vol. ASSP-23, pp. 242-243, April 1975.
- [71] R. DeCarlo, R. Saeks and J. Murray, "A Nyquist-like test for the stability of two-dimensional digital filters," Proc. IEEE, Vol. 65, No. 6, pp. 978-979, June 1977.
- [72] R. DeCarlo, R. Saeks and J. Murray, "Three graphical tests for the stability of multidimensional digital filters," 1977 IEEE Intl. Symp. Circuits and Systems, pp. 665-669.
- [73] R. R. Read and S. Treitel, "The stabilization of two-dimensional recursive filters via the discrete Hilbert transform," IEEE Trans.

Geoscience Elect., Vol. GE-11, pp. 153-160, July 1973.

- [74] N. K. Bose, "Problem in stabilization of multidimensional filters via Hilbert transform," IEEE Trans. Geoscience Electronics, pp. 146-147, Oct. 1974.
- [74a] J. W. Woods, Ibid, p. 104, July, 1974.
- [74b] J. Murray, "Spectral Factorization and Quarter-Plane Digital Filters," Inst. for Elect. Science, Texas University, Lubbock, Texas, 1978.
- [75] J. L. Shanks, S. Treital and J. H. Justice, "Stability and synthesis of two-dimensional recursive filters," IEEE Trans. Audio and Electroacoustics, Vol. AU-20, pp. 115-128, 1972.
- [76] J. B. Bednar, "On the stability of the least-square inverse process in 2-D digital filters," IEEE Trans. on ASSP, Vol. ASSP-23, No. 6, pp. 583-585, Dec. 1975.
- [77] Y. Genin and Y. Kamp, "Counter-example in the least squares inverse stabilization of 2-D recursive filters," Elect. Letters, Vol. 11, pp. 330-331, July 1975.
- [78] Y. Genin and Y. Kamp, "Two-dimensional stability and orthogonal polynomials on the hypercircle," Proc. IEEE, Vol. 65, No. 6, pp. 873-881, June 1977.
- [79] B. D. O. Anderson and E. I. Jury, "Proof of a special case of Shanks' conjecture," IEEE Trans. on ASSP, Dec. 1976.
- [80] E. I. Jury, V. R. Kolavennu and B. D. O. Anderson, "Stabilization of certain two-dimensional recursive digital filters," Proc. IEEE, Vol. 65, No. 6, pp. 887-892, June 1977.
- [81] E. I. Jury, "An overview of Shanks' conjecture and comments on its validity," Proc. Tenth Asilomar Conf. Circuits, Systems and Computers, Calif., Nov. 1976.
- [82] J. P. Burg, "Three dimensional filtering with an array of seismometers," Geophysics, Vol. 24, pp. 693-713, Oct. 1964.



- [83] O. S. Halpeny and D. G. Childers, "Composite wavefront decomposition via multidimensional digital filtering of array data," IEEE Trans. Circuits and Systems, pp. 552-563, June 1975.
- [84] N. K. Bose, K. Zaki and R. W. Newcomb, "A multivariable bounded reality criterion," J. Franklin Inst., Vol. 297, No. 6, pp. 476-484, 1974.
- [85] B. D. O. Anderson and R. W. Scott, "Output-feedback stabilization. Solution by algebraic methods," Proc. IEEE, Vol. 65, pp. 849-861, 1977.
- [86] R. W. Scott, "Stable linear multivariable systems design," Ph.D. Thesis, University of New Castle, New Castle, Australia, 1977.
- [87] B. D. O. Anderson and E. I. Jury, "Stability of multidimensional digital filters," IEEE Trans. on Circuits and Systems, Vol. CAS-21, pp. 300-304, March 1974.
- [87a] S. Takahashi and S. Tsujii, "Stability condition for N-dimensional digital filters and extreme problems for polynomials of several variables," Electronics and Communications in Japan, Vol. 57-A, No. 10, p. 49, 1974.
- [88] N. K. Bose and E. I. Jury, "Positivity and stability tests for multi-dimensional filters (discrete-continuous)," IEEE Trans. on ASSP, Vol. ASSP-22, pp. 174-180, June 1974.
- [89] N. K. Bose and E. I. Jury, "Stability tests for multidimensional filters (discrete-continuous)," Intl. Conf. on Circuits, San Francisco, 1974.
- [90] A. R. Modaresi and N. K. Bose, "A multivariable polynomial non-negativity test," Proc. IEEE, Vol. 64, pp. 283-285, 1976.
- [91] N. K. Bose and P. S. Kamat, "Algorithm for stability test of multidimensional filters," IEEE Trans. on ASSP, Vol. ASSP-22, pp. 307-314, Oct. 1974.

- [92] D. D. Šiljak, "Stability criteria for multivariable polynomials," Electr. Lett., Vol. 11, pp. 217-218, 1975.
- [93] M. Ahmadi and R. A. King, "A Stability Criterion for N-dimensional zero-phase recursive digital filters," Proc. IEEE, Vol. 65, No. 6, pp. 893-898, 1977.
- [94] T. A. Bickart and E. I. Jury, "Real polynomials: Non-negativity and positivity," to be published.
- [95] T. A. Bickart and E. I. Jury, "Real polynomials: Non-global, non-negativity and non-global positivity," to be published.
- [96] W. S. Gesing and E. J. Davison, "Global minimization of polynomials of n-variables with control applications," Proc. Fourteenth Annual Allerton Conf. on Circuits and System Theory, University of Illinois, Urbana, Illinois, 1976.
- [97] H. H. Rosenbrock, State Space and Multivariable Theory, John Wiley & Sons, Inc., 1970.
- [98] W. A. Wolovich, Linear Multivariable Systems, Springer-Verlag, New York, 1974.
- [99] C. A. Desoer and M. Vidyasagar, Feedback Systems: Input-Output Properties, Academic Press, 1975.
- [100] C. C. MacDuffee, The Theory of Matrices, Chelsea, New York, p. 35, 1956.
- [101] N. Bourbaki, Algèbre, Hermann, Paris, Ch. VI, No. 11, p. 9, 1964.
- [102] V. M. Popov, "Some properties of the control systems with irreducible matrix transfer fractions," Lecture Notes in Mathematics, Vol. 144, Seminar on Diff. Eqns. and Dynamical Systems, Springer-Verlag, Berlin, New York, pp. 169-180, 1970.
- [103] S. H. Wang, "Design of linear multivariable systems," Memo No. ERL/M309, Elec. Res. Lab., Univ. of Calif., Berkeley, 1971.

- [104] W. A. Wolovich, "The determination of state-space representations for linear multivariable systems," Second IFAC Symp. on Multivariable Technical Control Systems, Dusseldorf, Germany, 1971.
- [105] C. A. Desoer and J. D. Schulman, "Cancellations in multivariable continuous time and discrete time feedback systems," Memo No. ERL/M346, Elec. Res. Lab., Univ. of Calif., Berkeley, 1972.
- [106] B. D. O. Anderson and R. E. Bitmead, "Stability of matrix polynomials," Int. J. Control, Vol. 26, No. 2, pp. 235-247, 1977.
- [107] L. Shieh and S. Sacheti, "A matrix in the Schwarz block form and the stability of matrix polynomials," to be published.
- [108] M. A. Ostrowski, "Notes on bounds for determinants with dominant principle diagonal," Proc. Amer. Math. Soc., Vol. 3, pp. 26-30, 1952.
- [109] A. G. MacFarlane, "Return-difference and return-ratio matrices and their use in analysis and design of multivariable feedback control systems," Proc. Inst. Elec. Engrs., Vol. 1117, p. 2037, 1970.
- [110] A. G. J. MacFarlane and I. Postlethwaite, "Characteristic frequency functions and characteristic gain functions," Int. J. Control, Vol. 26, No. 2, pp. 265-278, 1977.
- [111] J. F. Barman and J. Katzenelson, "A generalized Nyquist-type stability criterion and multivariable feedback systems," Int. J. Control, Vol. 20, No. 4, pp. 593-622, 1974.
- [112] R. Saeks, "On the encirclement condition and the generalization," IEEE Trans. Circuits and Systems, Vol. 22, p. 78, 1975.
- [113] R. DeCarlo and R. Saeks, "The encirclement condition are approach using algebraic topology," Int. J. Control, Vol. 26, No. 21, pp. 279-287, 1977.

- [114] S. Attasi, "Stochastic state space representation of images," in Lecture Notes in Economics and Mult. Systems 107, Springer-Verlag, Berlin, pp. 218-230, 1975.
- [115] E. Fornasini and G. Marchesini, "State-space realization theory for two dimensional filters," IEEE Trans. Auto. Contr., pp. 484-492, Aug. 1976.
- [116] R. P. Roesser, "A discrete state-space model for linear image processing," IEEE Trans. on Auto. Contr., Vol. AC-20, pp. 1-10, Feb. 1975.
- [116a] R. P. Roesser, "Multidimensional Linear Iterative Circuits General Properties," IEEE Trans. on Computers, Vol. C-21, No. 10, Oct. 1972, pp. 1067- 1073.
- [117] S. Kung, B. Lévy, M. Morf and T. Kailath, "New results in 2-D systems theory, Part II: 2-D state-space models -- realization and the notions of controllability, observability and minimality," Proc. IEEE, Vol. 65, No. 6, pp. 945-961, June 1977.
- [118] M. B. Morf, B. Lévy and S. Y. Kung, "New results in 2-D system theory, Part I: 2-D polynomial matrices, factorization and coprimeness," Proc. IEEE, pp. 861-872, June 1977.
- [119] A. S. Willsky, "Digital signal processing and control and estimation theory -- Points of tangency, area of intersection, and parallel directions," Electronics System Lab., M. I. T., ESL-R-712, Jan. 1976.
- [120] C. S. Koo and C. T. Chen, "Fadeeva's algorithm for spatial dynamical equations," Proc. IEEE, Vol. 65, No. 6, pp. 975-976, June 1977.
- [120a] N. S. Williams, "Transfer Function and Characteristic Equation of Delay Differential Systems," Control Systems Center, Report No. 14, Aug. 1973, University of Manchester, Inst. of Sci. and Tech., Manchester.

- [121] M. S. Peikarski, "Algebraic characterization of matrices whose multivariable characteristic polynomial is Hermitzian," Int. Symp. on Operator Theory, Lubbock, Texas, pp. 121-126, Aug. 1977.
- [122] W. E. Alexander and S. A. Pruess, "A new approach to stability analysis of 2-D recursive filters," to be published.
- [122a] W. E. Alexander, "Stability and Synthesis of Two-Dimensional Digital Recursive Filters," Ph.D. Thesis, University of New Mexico, 1974.
- [123] A. F. Humes and E. I. Jury, "A graphical stability test of two-dimensional multi-input multi-output digital filters," presented at the 12th Asilomar Conf., Monterey, California, Nov. 1977.
- [124] A. F. Humes and E. I. Jury, "Stability for n-dimensional multi-input multi-output linear digital filters," to be published.
- [125] P. E. Barry, R. Cran and C. R. Waters, "Two dimensional filtering -- a state estimator approach," Proc. 1976 Conf. on Decision and Control, Florida, pp. 613-618, Dec. 1976.
- [126] B. Lévy, M. Morf and S. K. Kung, "New results in 2-D systems theory, Part III: Recursive realization and estimation algorithms for 2-D systems," presented at the Decision and Control Conf., Florida, Dec. 1976.
- [127] A. J. Berkhout, "Stability and least square estimation," Automatica, Vol. 11, pp. 637-638, 1975.
- [128] A. Viera and T. Kailath, "On another approach to the Schur-Cohn Criterion," IEEE Trans. on Circuits and Systems, pp. 218-220, April 1977.
- [129] J. H. Justice, "A Levinson-type algorithm for two-dimensional Wiener filtering using Bivariate Szegö polynomials," Proc. IEEE, Vol. 65, No. 6, pp. 882-886, June 1977.
- [130] A. V. Oppenheim (ed.), Applications of Digital Signal Processing, Prentice Hall, New York, 1978.

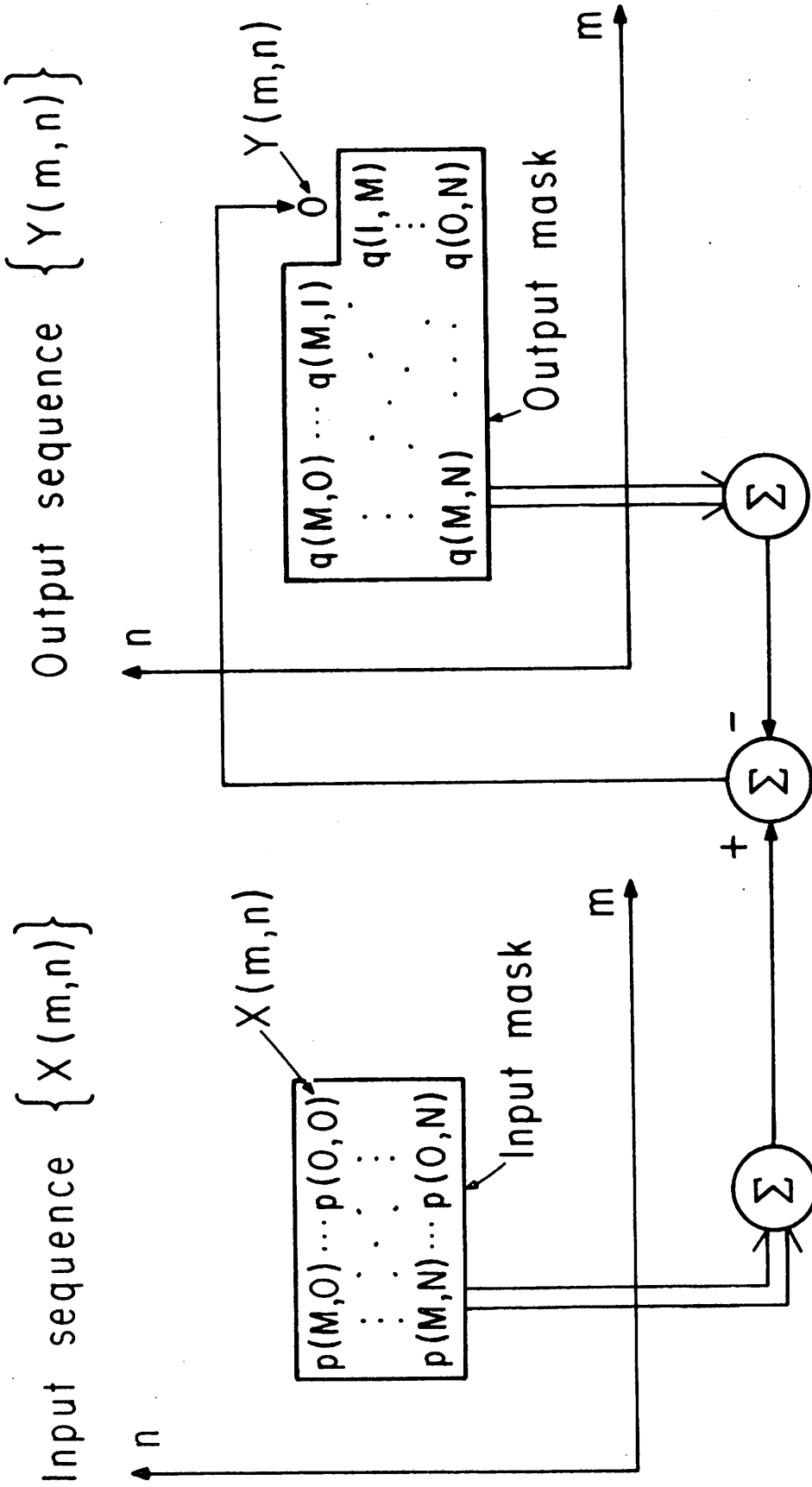

Fig. 1. Diagram of how the output sequence of Eq. (7)

is computed with a first quadrant filter.

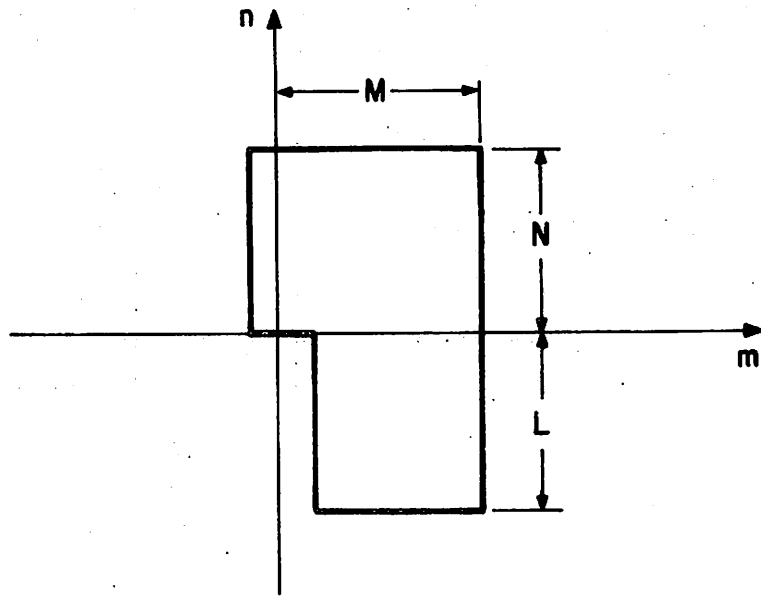

Fig. 2. Region of support for the weighting coefficient in Eq. (21).

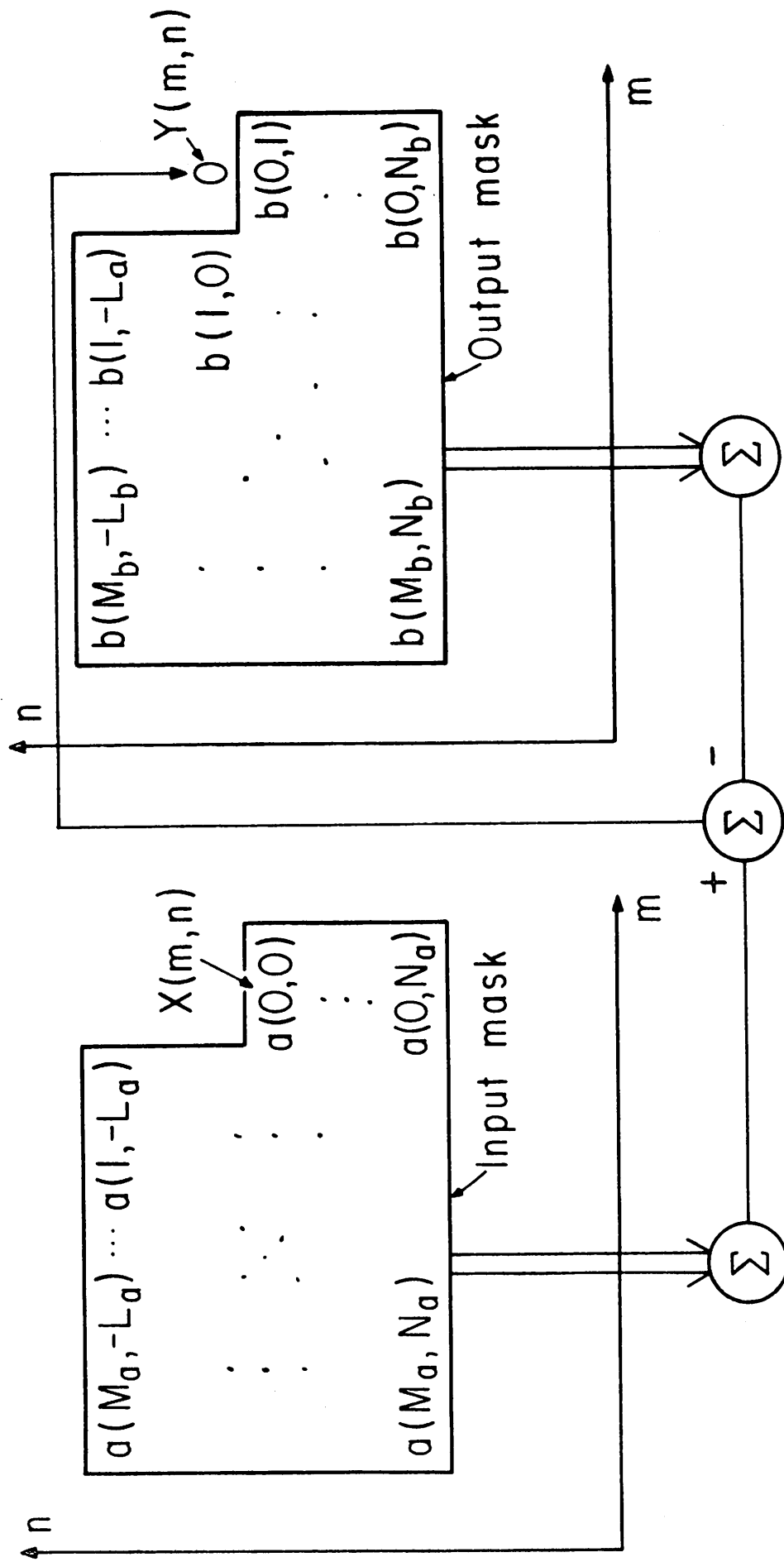

Fig. 3. Diagram of how the output sequence is computed for filters with difference Eq. (21).



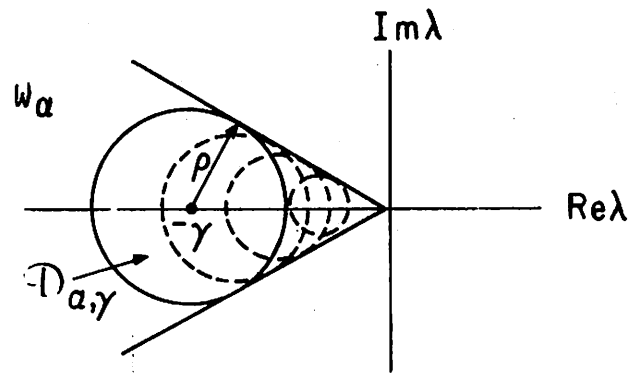

Fig. 4. Region  $\omega_\alpha$  for  $A(\alpha)$  stability.

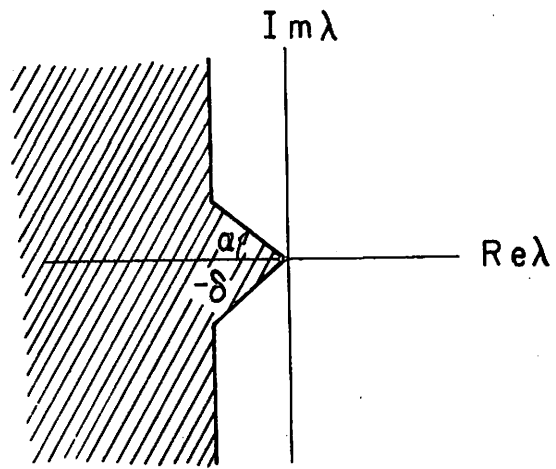

Fig. 5. Region for stiff-stability.

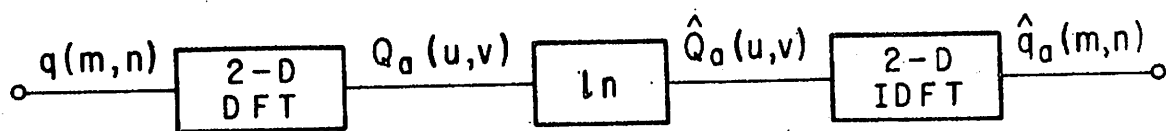

Fig. 6. Block diagram of the Cepstral stability test.