

Copyright © 1982, by the author(s).
All rights reserved.

Permission to make digital or hard copies of all or part of this work for personal or classroom use is granted without fee provided that copies are not made or distributed for profit or commercial advantage and that copies bear this notice and the full citation on the first page. To copy otherwise, to republish, to post on servers or to redistribute to lists, requires prior specific permission.

HIGH-ORDER NONLINEAR CIRCUIT ELEMENTS:
CIRCUIT-THEORETIC PROPERTIES

by

Leon O. Chua and Ellen W. Szeto

Memorandum No. UCB/ERL M82/27

16 April 1982

ELECTRONICS RESEARCH LABORATORY
College of Engineering
University of California, Berkeley
94720

HIGH-ORDER NONLINEAR CIRCUIT ELEMENTS:
CIRCUIT-THEORETIC PROPERTIES[†]

by

Leon O. Chua and Ellen W. Szeto^{††}

Abstract

Higher- and mixed-order nonlinear circuit elements have been introduced to provide a logically complete formulation for nonlinear circuit theory. In this paper, we analyze the circuit-theoretic properties of these elements, including reciprocity, passivity and losslessness. We have derived necessary and sufficient conditions for a higher- or mixed-order n-port element to be reciprocal or antireciprocal. We have shown that under very mild assumptions, most nonlinear higher-order 2-terminal elements are active and not lossless. Finally, we show that the number of lossless linear higher-order 2-terminal elements far exceeds that of the passive linear elements.

[†]Research supported by the Air Force Office of Scientific Research (AFSC) United States Air Force under Contract No. F49620-79-C-0178.

^{††}The authors are with the Department of Electrical Engineering and Computer Sciences, and the Electronics Research Laboratory at the University of California, Berkeley, CA 94720.

1. INTRODUCTION

Higher- and mixed-order elements have been introduced in [1] to provide a logically complete formulation for nonlinear circuit theory. In [2], we have shown that these elements can be synthesized using only linear reactances, linear controlled sources, and two-terminal nonlinear resistors. Our synthesis procedure indicates that a distinctive feature of higher- and mixed-order elements is that they possess internal dynamics that are more complicated than those of conventional circuit elements. In this paper, we shall provide an analysis of the circuit-theoretic properties that result from such complicated dynamics.

In Section 2, we derive necessary and sufficient conditions for a higher- or mixed-order n -port element to be reciprocal or antireciprocal. These conditions are applicable to an n -port element described by a " $v^{(\alpha)}$ -controlled," " $i^{(\beta)}$ -controlled," or a "hybrid" representation. We shall see that these conditions reduce to the well-known reciprocity or anti-reciprocity criteria for conventional n -port elements.

Section 3 deals with passivity and activity of 2-terminal higher-order elements described by an explicit representation, $v^{(\alpha)} = f(i^{(\beta)})$. There are basically three main results in this section. Theorem 3.1 takes the well-known result that a 2-terminal negative resistor, inductor or capacitor is active, and extends it to a much larger class of elements. Theorem 3.2 shows, in essence, that almost independently of the properties of $f(\cdot)$, the condition $|\beta - \alpha| \geq 2$ implies activity. Most of the results covered in these two theorems are statements about when a 2-terminal higher-order element is active. Equivalently, we are establishing a set of necessary conditions for passivity. As a result, the only possible (nonlinear) candidates for passivity are those lying on the solid lines in the circuit-element array in Figure 2. Finally, Theorems 3.3 and 3.4 treat the linear case in great detail; since in that case, it is possible to derive both necessary and sufficient conditions for passivity for a subclass of elements. The passive linear elements in this subclass are shown by the solid lines in Figure 4.

In Section 4, we study the losslessness of 2-terminal higher-order elements, also described explicitly by $v^{(\alpha)} = f(i^{(\beta)})$. Just as in the case of passivity, we shall introduce three main results in this section. Theorem 4.1 parallels Theorem 3.1 in the sense that we shall show that a large class of higher-order elements can never be lossless. Theorem 4.2 states a sufficient condition for the losslessness of the state representations for a very specific class of elements,

namely, those lying on the -45° line $\alpha+\beta = -1$, as shown in Fig. 5. There is no analogy to this result in our passivity theory. Finally, Theorem 4.3 states a necessary and sufficient condition for losslessness for a subclass of linear higher-order elements. The lossless elements belonging to this subclass are represented by the solid lines in Figure 6. Even though the same subclass of linear elements are considered for both passivity and losslessness, by comparing Figures 4 and 6 we can see that the number of lossless linear elements far exceeds that of the passive linear elements. This observation shows that the traditional practice in classical circuit theory to study losslessness only for passive circuits or circuit elements is too restrictive.

Finally, Section 5 contains our concluding remarks and suggests possible avenues for future research. For brevity, most of the results in this paper will be presented without proof. The interested reader is referred to [3] for detailed proofs.

2. RECIPROCITY AND ANTI-RECIPROCITY

Let N be a time-invariant n -port described explicitly by

$$\xi = f(\eta) \tag{2.1}$$

where $f : \mathbb{R}^n \rightarrow \mathbb{R}^n$,

$$\xi = (v_1^{(\alpha_1)}, v_2^{(\alpha_2)}, \dots, v_k^{(\alpha_k)}, i_{k+1}^{(\beta_{k+1})}, \dots, i_n^{(\beta_n)}),$$

$$\eta = (i_1^{(\beta_1)}, i_2^{(\beta_2)}, \dots, i_k^{(\beta_k)}, v_{k+1}^{(\alpha_{k+1})}, \dots, v_n^{(\alpha_n)}).$$

and for $z = v_j$ or i_j , $j = 1, 2, \dots, n$,

$$\left. \begin{aligned} z^{(k)}(t) &\triangleq \frac{d^k z(t)}{dt^k} \\ z^{(-k)}(t) &\triangleq z^{(-k)}(0) + \int_0^t z^{(-k+1)}(t) dt \end{aligned} \right\} \text{ for } k = 0, 1, 2, \dots$$

where $z^{(-k)}(0)$ is an arbitrary constant

Definition 2.1. Equation (2.1) is defined to be

- a) an $i^{(\beta)}$ -controlled representation if $k = n$,
- b) a $v^{(\alpha)}$ -controlled representation if $k = 0$, and
- c) a hybrid representation if $0 < k < n$.

□

Definition 2.2. In the case where $f: \mathbb{R}^n \rightarrow \mathbb{R}^n \in C^1$, we define the associated linearized n-port N_Q of N about the operating point $Q \triangleq (\xi_Q, \eta_Q)$ by

$$\hat{\xi} = \Lambda(\eta_Q)\hat{\eta},$$

where $\hat{\xi}$ and $\hat{\eta}$ denote the corresponding port variables¹ of N_Q and $\Lambda(\eta_Q) \in \mathbb{R}^n \times \mathbb{R}^n$ denotes the constant real Jacobian matrix

$$\Lambda(\eta_Q) \triangleq \left. \frac{d}{d\eta} f(\eta) \right|_{\eta=\eta_Q} . \quad \square$$

Definition 2.3. Let N be a time-invariant n-port described by any of the representations given in Definition 2.1, where $f: \mathbb{R}^n \rightarrow \mathbb{R}^n \in C^1$. Let N_Q denote its associated linearized n-port.

a) N is reciprocal (resp., anti-reciprocal) about an operating point Q iff the following condition holds: for any $(\hat{\xi}', \hat{\eta}')$ and $(\hat{\xi}'', \hat{\eta}'')$ belonging to N_Q , the associated voltage-current pairs (\hat{v}', \hat{i}') and (\hat{v}'', \hat{i}'') satisfy²

$$\hat{v}' * \hat{i}'' = \hat{v}'' * \hat{i}' \quad (2.2a)$$

$$\text{(resp., } \hat{v}' * \hat{i}'' = -\hat{v}'' * \hat{i}') \quad (2.2b)$$

b) N is reciprocal (resp., anti-reciprocal) iff it is reciprocal (resp., anti-reciprocal) at all operating points Q .

c) N is non-reciprocal iff it is neither reciprocal nor anti-reciprocal. □

Remark. According to Definition (2.3), the only relevant signal pairs $(\hat{\xi}, \hat{\eta})$ in considering reciprocity or anti-reciprocity are those starting from the bias point Q ; therefore, zero-initial conditions are implicitly assumed. It is, therefore, usually more convenient to work in the frequency domain in which conditions (2.2a) and (2.2b) become

$$\langle V'(s), I''(s) \rangle = \langle V''(s), I'(s) \rangle \quad (2.3a)$$

and

$$\langle V'(s), I''(s) \rangle = -\langle V''(s), I'(s) \rangle , \quad (2.3b)$$

¹In practice, $\hat{\xi}$ and $\hat{\eta}$ are simply the small-signal components of ξ and η . Here, $(\hat{\xi}, \hat{\eta})$ can be any signal pair satisfying $\hat{\xi} = \Lambda(\eta_Q)\hat{\eta}$.

²Here, the notation " $x*y$ " for two \mathbb{R}^n -valued time functions x and y denote the convolution

$$[x(\cdot)*y(\cdot)](t) \triangleq \sum_{k=1}^n \int_{-\infty}^{\infty} x_k(\tau)y_k(t-\tau)d\tau$$

where $V'(s)$, $V''(s)$, $I'(s)$, $I''(s)$ denote the Laplace Transform³ of $\hat{v}'(t)$, $\hat{v}''(t)$, $\hat{i}'(t)$, $\hat{i}''(t)$, respectively, and $\langle \cdot, \cdot \rangle$ denotes the vector dot product in \mathbb{R}^n .

Theorem 2.1. Let N be an $i^{(\beta)}$ -controlled higher- or mixed-order n -port element as described in Definition 2.1. Let $\Lambda(\eta_Q)$ be the Jacobian matrix of the associated linearized n -port N_Q , as given in Definition 2.2:

a) N is reciprocal if, and only if

$$\left. \begin{array}{l} \text{(i) } \alpha_j + \beta_j = \alpha_k + \beta_k \quad \forall j, k = 1, 2, \dots, n, \\ \text{and} \\ \text{(ii) } \Lambda(\eta_Q) \text{ is symmetric } \forall \eta_Q \in \mathbb{R}^n. \end{array} \right\} \quad (2.4)$$

b) N is anti-reciprocal if, and only if

$$\left. \begin{array}{l} \text{(i) } \alpha_j + \beta_j = \alpha_k + \beta_k \quad \forall j, k = 1, 2, \dots, n, \\ \text{and} \\ \text{(ii) } \Lambda(\eta_Q) \text{ is skew-symmetric } \forall \eta_Q \in \mathbb{R}^n \end{array} \right\} \quad (2.5)$$

Remark. A dual result holds for the case where N is $v^{(\alpha)}$ -controlled. Note that the current-controlled n -port resistor and inductor, and the charge controlled n -port capacitor all satisfy condition (i) in parts a) and b) of the above theorem; in which case, this theorem reduces to the reciprocity or antireciprocity criteria given in [4].

Proof. Since N is an $i^{(\beta)}$ -controlled higher-order or mixed-order n -port, its associated linearized n -port N_Q can be described by

$$\hat{\xi}(t) = \Lambda(\eta_Q) \hat{\eta}(t),$$

where

$$\hat{\xi}(t) = (\hat{v}_1^{(\alpha_1)}(t), \dots, \hat{v}_n^{(\alpha_n)}(t))$$

and

$$\hat{\eta}(t) = (\hat{i}_1^{(\beta_1)}(t), \dots, \hat{i}_n^{(\beta_n)}(t)).$$

The Laplace Transform of the above can be written as

$$V(s) = A^{-1} \Lambda(\eta_Q) B I(s) \quad (2.6)$$

$$\underline{\underline{\Delta}} \Omega(\eta_Q) I_s,$$

³For an \mathbb{R}^n -valued time function x , we define its Laplace Transform to be

$$\mathcal{L}(x) = \int_{-\infty}^{\infty} e^{-st} x(t) dt \underline{\underline{\Delta}} X(s).$$

where $V(s)$ (resp., $I(s)$) denotes the Laplace Transform of the voltage (resp., current) vector associated with $\hat{\xi}(t)$ (resp., $\hat{\eta}(t)$),

$A \triangleq \text{diag}(S^{\alpha_1}, S^{\alpha_2}, \dots, S^{\alpha_n})$ is an $n \times n$ matrix,

and

$B \triangleq \text{diag}(S^{\beta_1}, S^{\beta_2}, \dots, S^{\beta_n})$ is also an $n \times n$ matrix.

Now let $(\hat{v}'(\cdot), \hat{i}'(\cdot))$ and $(\hat{v}''(\cdot), \hat{i}''(\cdot))$ be any two Laplace-transformable signals of N_Q , whose Laplace Transforms are $(V'(s), I'(s))$ and $(V''(s), I''(s))$, respectively.

a) A straightforward calculation using equation (2.6) shows that condition (2.3a) for reciprocity in this case is equivalent to

$$I''^T(s)[\Omega^T(\eta_Q) - \Omega(\eta_Q)]I'(s) = 0, \quad \forall \eta_Q, I''(s), \text{ and } I'(s).$$

This is true for all $I''(s)$, $I'(s)$ and η_Q if, and only if $\Omega^T(\eta_Q) = \Omega(\eta_Q)$ for all $\eta_Q \in \mathbb{R}^n$, i.e., $\Omega(\eta_Q)$ is symmetric for all possible values of η_Q . Let $\lambda_{jk}(\eta_Q)$ ($j, k = 1, 2, \dots, n$) represent the elements of the matrix $\Lambda(\eta_Q)$. Recalling the definition of $\Omega(\eta_Q)$ from equation (2.6), $\Omega(\eta_Q)$ is symmetric for all η_Q if, and only if

$$S^{\beta_k - \alpha_j} \lambda_{jk}(\eta_Q) = S^{\beta_j - \alpha_k} \lambda_{kj}(\eta_Q), \quad \forall \eta_Q.$$

This, in turn, holds if, and only if, for all $j, k = 1, 2, \dots, n$,

$$(i) \quad \alpha_j + \beta_j = \alpha_k + \beta_k$$

and

$$(ii) \quad \lambda_{jk}(\eta_Q) = \lambda_{kj}(\eta_Q) \quad \forall \eta_Q, \text{ i.e., } \Lambda(\eta_Q) \text{ is symmetric.}$$

Hence N is reciprocal if, and only if conditions (2.4) are satisfied.

b) For anti-reciprocity, condition (2.3b) is equivalent to requiring that

$$I''^T(s)[\Omega^T(\eta_Q) + \Omega(\eta_Q)]I'(s) = 0, \quad \forall \eta_Q, I'(s) \text{ and } I''(s).$$

Using similar arguments as part a), this is true if, and only if conditions (2.5) in the theorem are satisfied.

Example 2.1. Consider the mixed-order 2-port element:

$$\begin{aligned} v_1^{(-3)} &= 2i_1^{(-1)}i_2^{(-2)} \\ v_2^{(-2)} &= [i_1^{(-1)}]^2 \end{aligned} \tag{2.7}$$

The linearized 2-port about the operating point $Q \triangleq (i_{1Q}^{(-1)}, i_{2Q}^{(-2)})$ is described by

$$\begin{bmatrix} \hat{v}_1^{(-3)} \\ \hat{v}_2^{(-2)} \end{bmatrix} = \begin{bmatrix} 2i_{2Q}^{(-2)} & 2i_{1Q}^{(-1)} \\ 2i_{1Q}^{(-1)} & 0 \end{bmatrix} \begin{bmatrix} \hat{i}_1^{(-1)} \\ \hat{i}_2^{(-2)} \end{bmatrix} \quad (2.8)$$

Since $\alpha_j + \beta_j = -4$ for $j = 1, 2$, and the Jacobian matrix on the right side of equation (2.8) is symmetric for all η_Q , by Theorem 2.1, this 2-port is reciprocal. \square

Example 2.2. The mixed-order 2-port element

$$\begin{aligned} v_1^{(1)} &= 2i_1 i_2^{(-2)} \\ v_2 &= i_1^2 \end{aligned} \quad (2.9)$$

has $\alpha_1 + \beta_1 = 1$ and $\alpha_2 + \beta_2 = -2$. Despite the fact that the constitutive relation in this case takes on the same form as that of Example 1, this 2-port is non-reciprocal, since it does not satisfy condition (i) in both parts of Theorem 2.1. \square

Theorem 2.2. Let N be a higher- or mixed-order n -port element with a hybrid representation as described in Definition 2.1. Let $\Lambda(\eta_Q)$ be the Jacobian matrix of the associated linearized n -port N_Q , as given in Definition 2.2. With $0 < k < n$ as in Definition 2.1, we partition $\Lambda(\eta_Q)$ as follows:

$$\Lambda(\eta_Q) = \begin{bmatrix} \overbrace{\Lambda_{11}(\eta_Q)}^k & \overbrace{\Lambda_{12}(\eta_Q)}^{n-k} \\ \hline \Lambda_{21}(\eta_Q) & \Lambda_{22}(\eta_Q) \end{bmatrix} \begin{matrix} \left. \vphantom{\begin{bmatrix} \Lambda_{11}(\eta_Q) & \Lambda_{12}(\eta_Q) \\ \Lambda_{21}(\eta_Q) & \Lambda_{22}(\eta_Q) \end{bmatrix}} \right\} k \\ \left. \vphantom{\begin{bmatrix} \Lambda_{11}(\eta_Q) & \Lambda_{12}(\eta_Q) \\ \Lambda_{21}(\eta_Q) & \Lambda_{22}(\eta_Q) \end{bmatrix}} \right\} n-k \end{matrix} \quad (2.10)$$

a) N is reciprocal if, and only if

(i) $\alpha_j + \beta_j = \alpha_k + \beta_k \quad \forall j, k = 1, 2, \dots, n$

(ii) $\Lambda_{11}(\eta_Q)$ and $\Lambda_{22}(\eta_Q)$ are symmetric $\forall \eta_Q$,

and

(iii) $\Lambda_{12}(\eta_Q) = -\Lambda_{21}(\eta_Q), \forall \eta_Q$.

b) N is anti-reciprocal if, and only if

(i) $\alpha_j + \beta_j = \alpha_k + \beta_k \quad \forall j, k = 1, 2, \dots, n$,

and

(ii) $\Lambda(\eta_Q)$ is skew-symmetric for all η_Q . \square

Remark. The proof of this theorem is a straightforward generalization of that of Theorem 2.1, and is therefore omitted. For an n-port resistor with a Hybrid I or Hybrid II representation [4], Theorem 2.2 reduces to the usual reciprocity or anti-reciprocity criteria. However, Theorem 2.2 can be applied to a much larger class of n-port elements, as the following examples illustrate. \square

Example 2.3. The type 2 3-port traditor is described by [5]:

$$\begin{aligned} v_1 &= -Ai_2^{(-1)}v_3 \\ v_2 &= -Ai_1^{(-1)}v_3 \\ i_3^{(-1)} &= Ai_1^{(-1)}i_2^{(-1)} \end{aligned} \quad (2.11)$$

The linearized 3-port about an operating point $Q \triangleq (i_{1Q}^{(-1)}, i_{2Q}^{(-1)}, v_{3Q})$ associated with (2.11) is

$$\begin{bmatrix} \hat{v}_1 \\ \hat{v}_2 \\ \hat{i}_3^{(-1)} \end{bmatrix} = \begin{bmatrix} 0 & -Av_{3Q} & -Ai_{2Q}^{(-1)} \\ -Av_{3Q} & 0 & -Ai_{1Q}^{(-1)} \\ \hline Ai_{2Q}^{(-1)} & Ai_{1Q}^{(-1)} & 0 \end{bmatrix} \begin{bmatrix} \hat{i}_1^{(-1)} \\ \hat{i}_2^{(-1)} \\ \hat{v}_3 \end{bmatrix} \quad (2.12)$$

In this case, $\alpha_j + \beta_j = -1$ for $j = 1, 2, 3$, and condition (ii) in part a) of Theorem 2.2 is satisfied, we can conclude that the type 2 traditor is reciprocal. Using similar arguments, it is easy to show that all the six types of 3-port traditors are reciprocal. \square

Example 2.4. Consider a type 2 (α_1, β_1) - (α_2, β_2) higher-order mutator described by [2]

$$\begin{bmatrix} v_1^{(\alpha_1)} \\ i_1^{(\beta_1)} \end{bmatrix} = \begin{bmatrix} 0 & 1 \\ -1 & 0 \end{bmatrix} \begin{bmatrix} v_2^{(\alpha_2)} \\ i_2^{(\beta_2)} \end{bmatrix} \quad (2.13)$$

In the case where $\alpha_1 + \beta_1 = \alpha_2 + \beta_2$, the mutator of equation (2.13) is antireciprocal by part b) of Theorem 2.2. (For example, a gyrator which has $\alpha_1 = \alpha_2 = \beta_1 = \beta_2 = 0$ is known to be antireciprocal [4]). However, the mutator of equation (2.13) is non-reciprocal whenever $\alpha_1 + \beta_1 \neq \alpha_2 + \beta_2$. From this, we can conclude that any type 2 higher-order mutator transforming port variables along the lines $\alpha + \beta = \text{constant}$ are antireciprocal.

Example 2.5. A type 1 (α_1, β_1) - (α_2, β_2) higher-order mutator is described by

$$\begin{bmatrix} v_1^{(\alpha_1)} \\ i_1^{(\beta_1)} \end{bmatrix} = \begin{bmatrix} 1 & 0 \\ 0 & -1 \end{bmatrix} \begin{bmatrix} v_2^{(\alpha_2)} \\ i_2^{(\beta_2)} \end{bmatrix} \quad (2.14)$$

Whenever $\alpha_1 + \beta_1 = \alpha_2 + \beta_2$, the mutator of equation (2.14) is reciprocal by part a) of Theorem 2.2. Hence, any type 1 higher-order mutator transforming port variables along the lines $\alpha + \beta = \text{constant}$ are reciprocal. \square

3. PASSIVITY AND ACTIVITY

An electrical network is called passive if it is capable of delivering no more than a finite amount of energy to the outside world. In this section, we shall study the passivity property of a 2-terminal higher-order element with an $i^{(\beta)}$ -controlled representation:

$$v^{(\alpha)} = f(i^{(\beta)}) \quad (3.1)$$

Dual results can be obtained for the $v^{(\alpha)}$ -controlled case by interchanging the roles of $v^{(\alpha)}$ and $i^{(\beta)}$ in the subsequent discussions.

We are going to study passivity in a state-space setting as formulated in [6]. We first note that under very mild technical assumptions on the function f , every 2-terminal higher-order element described by equation (3.1) has a state representation:

$$\begin{aligned} \dot{x} &= f(x, u) \\ y \triangleq (i, v)^T &= g(x, u) \end{aligned} \quad (3.2)$$

Example 3.1. Consider the case where $\alpha \geq 1$ and $\beta \leq 1$. The state representation for the higher-order element is

$$\left\{ \begin{array}{l} \dot{x}_1 = u \\ \dot{x}_2 = x_1 \\ \vdots \\ \dot{x}_{|\beta|} = x_{|\beta|-1} \\ \dot{x}_{|\beta|+1} = f(x_{|\beta|}) \\ \dot{x}_{|\beta|+2} = x_{|\beta|+1} \\ \vdots \\ \dot{x}_{|\beta|+\alpha} = x_{|\beta|+\alpha-1} \end{array} \right\}, \quad \begin{bmatrix} i \\ v \end{bmatrix} = \begin{bmatrix} u \\ x_{|\beta|+\alpha} \end{bmatrix} \quad (3.3)$$

The technical assumption on f in this case is that it be Lebesgue-integrable. This example is typical of the four possible forms of state representations for the higher-order element of equation (3.1) with $\alpha \geq 0$ and $\beta \leq 0$ [3].

□

Example 3.2. With $\alpha = 0$ and $\beta \geq 1$, the state representation is

$$\left\{ \begin{array}{l} \dot{x}_1 = u \\ \dot{x}_2 = x_1 \\ \vdots \\ \dot{x}_\beta = x_{\beta-1} \end{array} \right\}, \quad \begin{bmatrix} i \\ v \end{bmatrix} = \begin{bmatrix} x_\beta \\ f(u) \end{bmatrix} \quad (3.4)$$

As in Example 3.1, the technical assumption on f in this case is that it be Lebesgue-integrable. This example is typical of the two possible forms of state representations for $\alpha \geq 0$ and $\beta \geq 1$ [3].

□

Example 3.3. With $\beta < \alpha \leq -1$, the higher-order element of equation (3.1) has the following state representation:

$$\left\{ \begin{array}{l} \dot{x}_1 = u \\ \dot{x}_2 = x_1 \\ \vdots \\ \dot{x}_{|\beta|} = x_{|\beta|-1} \end{array} \right\}, \quad \begin{bmatrix} i \\ v \end{bmatrix} = \begin{bmatrix} u \\ \tilde{f}(x_{|\beta|-|\alpha|}, \dots, x_{|\beta|-1}, x_{|\beta|}) \end{bmatrix}, \quad (3.5)$$

where the function \tilde{f} in the output equation is defined by

$$\tilde{f}(x_{|\beta|-|\alpha|}, \dots, x_{|\beta|}) \triangleq \frac{d^{|\alpha|}}{dt^{|\alpha|}} f(z) \Big|_{z=i(\beta)}$$

For such a representation to exist, we require that $f \in C^{|\alpha|-1}$. This example is typical of the four representations that can arise whenever $\alpha \leq -1$ [3].

The following is adapted from [6]:

Definition 3.1. Let $\Sigma \subseteq \mathbb{R}^n$ denote the state space of the 2-terminal higher-order element described by equation (3.1). Let $\mathcal{Y}(x_0)$ denote the set of all admissible values of $y(x,u) \triangleq (i(x,u), v(x,u))$ that evolve from the initial state $x_0 \in \Sigma$.

a) The available energy $E_A: \Sigma \rightarrow \mathbb{R}^+ \cup \{\infty\}$ of the element is defined to be

$$E_A(x_0) \triangleq \sup_{\substack{y \in \mathcal{Y}(x_0) \\ T \geq 0}} \left\{ - \int_0^T i(x(t), u(t)) v(x(t), u(t)) dt \right\} .$$

b) The element is passive iff $E_A(x_0) < +\infty$ for all $x_0 \in \Sigma$. Otherwise, it is defined to be active.

Theorem 3.1. Assume

- (i) there exists $a \in \mathbb{R}$ such that $af(a) < 0$, and
- (ii) $(\alpha=0, \beta \geq 0)$ or $(\alpha > 0, \beta=0)$.

The 2-terminal higher-order element described by $v^{(\alpha)} = f(i^{(\beta)})$ is active under these assumptions.

Proof. The proof consists of three parts due to the three different state representations that can occur when assumption (ii) is satisfied.

a) The state representation for the case $(\alpha=0, \beta \geq 1)$ is given in equation (3.4) of Example 3.2. By hypothesis, there exists $a \in \mathbb{R}$ such that if we denote $b \triangleq f(a)$, then $\text{sgn}(b) = -\text{sgn}(a)$ with $a \neq 0, b \neq 0$. Choose the initial state $x_0 = 0$. Let

$$u(t) = a, \quad \forall t \geq 0$$

$$\text{Then } i(t) = x_\beta(t) = \frac{at^\beta}{\beta!}, \quad \forall t \geq 0$$

$$v(t) = f(a) = b, \quad \forall t \geq 0.$$

and

$$E_A(x_0) = \sup_{T \geq 0} \left\{ - \int_0^T ab \frac{t^\beta}{\beta!} dt \right\} = +\infty.$$

Hence for our particular choice of $u(t)$ and x_0 , the available energy of the element is infinite. Therefore, the element is active by Definition 3.1.

b) For $(\alpha > 1, \beta=0)$, the state representation is [3]

$$\left\{ \begin{array}{l} \dot{x}_1 = f(u) \\ \dot{x}_2 = x_1 \\ \vdots \\ \dot{x}_\alpha = x_{\alpha-1} \end{array} \right\}, \quad \begin{bmatrix} i \\ v \end{bmatrix} = \begin{bmatrix} u \\ x_\alpha \end{bmatrix} \quad (3.6)$$

Choose the initial state $x_0 = 0$, and, for $t \geq 0$, pick

$$u(t) = a,$$

where a is as given in assumption (i) in the theorem. The proof of this part proceeds as in case a) above.

c) For $(\alpha=0, \beta=0)$, the state representation is [3]:

$$\dot{x}_1 = 0, \quad \begin{bmatrix} i \\ v \end{bmatrix} = \begin{bmatrix} u \\ f(u) \end{bmatrix} \quad (3.7)$$

Pick $u(t) = a$, for all $t \geq 0$, where a is as given in assumption (i) of the theorem and $x_0 =$ some arbitrary constant. Then it is easy to verify that

$$E_A(x_0) = \sup_{T \geq 0} \left\{ - \int_0^T ab \, dt \right\} = +\infty.$$

Hence the higher-order element is active.

Example 3.1. Consider the 2-terminal higher-order element

$$v^{(1)} = e^i, \quad (3.8)$$

as shown in Figure 1. The point marked "a" on the i - $v^{(1)}$ characteristic satisfies the hypothesis of the theorem, and therefore we can conclude that this element is active. It is worthwhile to point out that whereas the nonlinear capacitor described by $v = e^{i^{(-1)}}$ is passive [6], the element of equation (3.8) is nevertheless active, even though the current and voltage differ by the same order (i.e. $\beta - \alpha = -1$) in both cases. This illustrates the importance of recognizing that higher-order elements can exhibit properties that are quite different from those of conventional circuit elements. \square

Theorem 3.2. If $f: \mathbb{R} \rightarrow \mathbb{R}$ is piecewise-continuous whenever $\alpha \geq 0$ and $|f|$ times continuously differentiable whenever $\alpha < 0$, and, depending on the integer values

α and β , satisfies the conditions in Table 1,⁴ then the 2-terminal higher-order element $v^{(\alpha)} = f(i^{(\beta)})$ is active. □

Remarks. The proof of this theorem consists of a case by case analysis of the state representations corresponding to different values of α and β . The basic idea behind the proof follows the line of that of Theorem 3.1: to show activity of a particular element, we work in the corresponding state space Σ of the element. We find an input waveform $u(\cdot)$ and an initial condition $x_0 \in \Sigma$ such that the available energy $E_A(x_0)$ is infinite. For most of the cases covered in Theorem 3.2, the input waveforms used in proving activity are more complicated than that for Theorem 3.1. The details of the proof can be found in [3].

The essential content of this theorem is that $|\beta - \alpha| \geq 2$ implies activity, regardless of f , which is not too surprising when one considers the linear case (later on in Theorem 3.3). The remaining assumptions of the theorem may look complicated, but they actually boil down to excluding pathological cases (except, perhaps, in cases c) and i), where the assumptions needed to validate the proof are a bit stronger than one would have expected). Note, however, that some parts of the theorem statement -- specifically cases a), b) and j), allow the possibility of $|\beta - \alpha| \leq 1$ for activity, so the results are not simply an extension of "intuitively obvious" linear circuit properties. In particular, the following needs to be pointed out:

a) For $(\alpha \geq 1, \beta \geq 1)$, so long as the function f is piecewise-linear, the 2-terminal higher-order element $v^{(\alpha)} = f(i^{(\beta)})$ is always active. An obvious corollary to this is that the linear element $v^{(\alpha)} = ki^{(\beta)}$ with $\alpha, \beta \geq 1$ can never be passive, no matter what value k takes on.

b) and j): The results here for $(\alpha \geq 1, \beta = 0)$ and $(\alpha = 0, \beta \geq 1)$ only hold for functions that are not linear. We shall see later, when we consider the linear case, that passivity implies linearity in these cases. This is a truly interesting result because it is the first known instance (in state space theory) of elements which are passive when linear, and which, for any deviation, no matter how small, from linearity, become active. To illustrate the above observation, consider a $v^{(1)}-i^{(0)}$ element described by $i = f(v^{(1)})$, when $f(v^{(1)}) = Cv^{(1)}$ is linear, the element reduces to a linear capacitor and is therefore passive if $C \geq 0$. However, when $f(\cdot)$ is nonlinear, the element no longer behaves like a capacitor.

c) Applied to the linear case, this result for $(\alpha \geq 1, \beta = -1)$ states that, the

⁴The conditions on f can be further relaxed [3]. For ease of exposition, we shall omit all technical details.

element $v^{(\alpha)} = ki^{(-1)}$ with $\alpha \geq 1$ can never be passive. Note that $|\beta - \alpha| \geq 2$, i.e. $|\beta - \alpha|$ implies activity in this case, and the result here will appear as a direct consequence of Theorem 3.3, to be present later.

d) In this case ($\alpha > 0, \beta < -2$), all 2-terminal higher-order elements of practical interest are active. The only function f to which the theorem is inapplicable is the trivial case of $f(z) \equiv 0 \forall z \in \mathbb{R}$.

e)-i) The restrictions on f in these cases (where $\alpha \leq -1$) are satisfied by almost all functions that are $|\alpha|$ times continuously differentiable. Applied to the linear case, the results state that $|\beta - \alpha| \geq 2$ implies activity.

The above discussion shows that Theorem 3.2 says, in effect, that provided the function f satisfies certain minor restrictions, a large portion of 2-terminal higher-order elements described by $v^{(\alpha)} = f(i^{(\beta)})$ can never be passive. More specifically, we would expect to find the passive nonlinear elements to lie on the solid lines in the fourth quadrant of the circuit-element array, as shown in Figure 2. □

Example 3.2. Consider the charge-controlled memristor [4] described by

$$v^{(-1)} = [i^{(-1)}]^3 \quad (3.9a)$$

The above equation can be rewritten as

$$v = 3[i^{(-1)}]^2 i \quad (3.9b)$$

Note that for a given input signal $i(t)$ equation (3.9b) represents a time-varying linear resistor of the form

$$v(t) = R(t) i(t),$$

where $R(t) \geq 0 \forall t \geq 0$. Note, however, that $R(t)$ cannot be prescribed apriori, but changes with $i(t)$. It is easy to verify that for any initial state $x_0 = i^{(-1)}(0)$, the available energy of this memristor is

$$E_A(x_0) = \sup_{\substack{T > 0 \\ \text{admissible } i}} \{-\int_0^T i(t) v(t) dt\} = 0,$$

and therefore the memristor is passive. □

Example 3.3. Consider the 2-terminal higher-order element described by

$$v^{(-1)} = f(i^{(-2)}), \quad (3.10a)$$

where $f: \mathbb{R} \rightarrow \mathbb{R} \in C^1$.

We can recast the above equation as

$$v = f'(i^{(-2)})i^{(-1)}, \quad (3.10b)$$

where $f'(i^{(-2)}) \triangleq \left. \frac{d}{dz} f(z) \right|_{z=i^{(-2)}}$.

Note that (3.10b) is just the constitutive relation for a time-varying linear capacitor, of the form

$$v(t) = C(t) i^{(-1)}(t),$$

(where $C(t) \triangleq f'(i^{(-2)}(t))$)

Provided that $C(t) \geq 0$ for all time $t \geq 0$, i.e., $f'(z) \geq 0$ for all $z \in \mathbb{R}$, the higher-order element of equation (3.10) is passive. This can be verified by considering the integral

$$\int_0^T i(t) v(t) dt = \int_0^T C(t) i^{(-1)}(t) i(t) dt. \quad (3.11)$$

Since $C(t) \geq 0 \forall t \in [0, T]$ and $C(t)$ is continuous in that interval (because $f \in C^1$), it must attain a maximum and a minimum value. Denote the minimum by $C_{\min}(T)$. From equation (3.11), we get

$$-\int_0^T i(t) v(t) dt \geq -C_{\min}(T) \int_{i^{(-1)}(0)}^{i^{(-1)}(T)} i^{(-1)} di^{(-1)}$$

For any initial state $x_0 = i^{(-1)}(0)$ in the state space, the available energy is given by

$$\begin{aligned} E_A(x_0) &= \sup_{\substack{T > 0 \\ \text{admissible } i}} \{-C_{\min}(T) \int_{i^{(-1)}(0)}^{i^{(-1)}(T)} i^{(-1)} di^{(-1)}\} \\ &= \sup_{\substack{T > 0 \\ \text{admissible } i}} \{C_{\min}(T) [(i^{(-1)}(0))^2 - (i^{(-1)}(T))^2]\} \\ &= \sup_{T > 0} \{C_{\min}(T) (i^{(-1)}(0))^2\} \end{aligned}$$

Since for all $T \geq 0$, we have $0 \leq C_{\min}(T) < \infty$, the available energy is dependent only on the initial state $i_0^{(-1)}(0)$, and is bounded for each given value of $i_0^{(-1)}(0)$, we can conclude that the element is passive.⁵ The condition $f'(z) \geq 0 \forall z \in \mathbb{R}$ is satisfied by many simple functions, as for example, $f(z) = e^z$. Hence, the higher-order 2-terminal element $v^{(-1)} = e^{i^{(-2)}}$ is passive. This is to be contrasted with Example 3.1, which shows that the element $v^{(1)} = e^i$ is active.

The above two examples may lead one to believe that the passivity criteria for those 2-terminal elements shown in Figure 2 are the same as those of the conventional circuit elements. However, this is not always the case, as the following example illustrates:

Examples 3.4. Consider the 2-terminal higher-order element described by

$$v^{(-2)} = [i^{(-2)}]^3 \tag{3.12a}$$

By analogy with Example 3.2, one may expect this element to behave like a time-varying resistor, and should therefore be passive. We shall now show that such an "intuitive" reasoning is incorrect. Rewriting equation (3.12a) in a familiar form, we obtain:

$$v = 6i^{(-2)}[i^{(-1)}]^2 + 3[i^{(-2)}]i \tag{3.12b}$$

By applying an input current $i(t) = \cos t$ for $t \geq 0$, and considering zero initial conditions, we can find that the available energy of the element described by equation (3.12) is given by

$$E_A(0) = \sup_{T \geq 0} \left\{ 6 \left[\frac{T}{8} - \frac{\sin 4T}{32} + 2 \sin T - 2 \frac{\sin^3 T}{3} \right] \right\}$$

$$= +\infty.$$

Hence, the higher-order element of equation (3.12) is active. □

Theorem 3.3. Let P_L denote the class of linear 2-terminal higher-order elements described by

$$v^{(\alpha)} = k i^{(\beta)}, \quad k \in \mathbb{R} \tag{3.13}$$

⁵A similar argument shows that the higher-order 2-terminal element described by $i^{(-1)} = g(v^{(-2)})$ behaves like a time-varying linear inductor, and is therefore passive when $\frac{d}{dz} g(z) \geq 0 \forall z \in \mathbb{R}$.

satisfying

$$\left. \begin{array}{l} \text{(i) } \alpha \leq 0 \text{ or} \\ \text{(ii) } \alpha \geq 1 \text{ and } \underline{\text{the initial conditions}} \ v^{(\alpha-j)}(0) = ki^{(\beta-j)}(0), \ j = 2, \dots, \alpha \end{array} \right\} \quad (3.14)$$

Any 2-terminal higher-order element belonging to the class P_L is passive if, and only if

a) $|\beta - \alpha| \leq 1$ and

b) $k \geq 0$ (with $k > 0$ only when $\alpha = 1$) □

Remark. Although Theorem 3.3 considers a relatively small subclass of linear 2-terminal higher-order elements, it is nevertheless all that we really need to consider, since most of the elements not belonging in the class P_L have been shown to be active in Theorem 3.2. In fact, the only linear elements which are covered by neither Theorem 3.2 nor Theorem 3.3 are those in cases $(\alpha=0, \beta \geq 1)$ and $(\alpha \geq 1, \beta=0)$. These will be considered later, in Theorem 3.4. We would also like to stress that in Theorem 3.3, for the case $\alpha \geq 1$, we are only considering those elements with constrained initial conditions; and such elements are quite different from those considered in Theorem 3.2. For example, the linear higher-order element $v^{(1)} = kv^{(1)}$, whose initial conditions satisfy $v(0) = ki(0)$ is no different from a linear resistor $v = ki$, which is passive if, and only if $k \geq 0$. The very same element with unconstrained initial conditions is very different from a linear resistor -- it has to be built using linear reactive elements and controlled sources, as shown in Figure 3 (where the 1F capacitors can have arbitrary initial conditions). The implications of this remark on the definition of passivity can be found in [7].

Proof. We first note that except for the case $\alpha = 1$, every element in P_L has an equivalent representation⁶

$$v = ki^{(\beta-\alpha)} \quad (3.15)$$

If $|\beta - \alpha| = 0$, (3.15) is just a 2-terminal linear resistor which is passive if, and only if, $k \geq 0$. The only case we have to consider is when $|\beta - \alpha| \neq 0$. In this case, the element has the following state representation:

⁶Representation (3.15) is equivalent to the original representation (3.13) in the sense that they both possess the same set of voltage-current pairs.

$$\dot{x} = \begin{bmatrix} \dot{x}_1 \\ \dot{x}_2 \\ \vdots \\ \dot{x}_{|\beta-\alpha|} \end{bmatrix} = \begin{bmatrix} 0 & & & & \\ & 1 & & & \\ & & \ddots & & \\ & & & 1 & \\ & & & & 0 \end{bmatrix} \begin{bmatrix} x_1 \\ x_2 \\ \vdots \\ x_{|\beta-\alpha|} \end{bmatrix} + \begin{bmatrix} 1 \\ 0 \\ \vdots \\ 0 \end{bmatrix} u, \quad (3.16a)$$

$$\begin{bmatrix} i \\ v \end{bmatrix} = \begin{cases} \begin{bmatrix} 0 & 0 & \cdots & 0 & 0 \\ 0 & 0 & \cdots & 0 & k \end{bmatrix} x + \begin{bmatrix} 1 \\ 0 \end{bmatrix} u, & \beta - \alpha < 0 \\ \begin{bmatrix} 0 & 0 & \cdots & 0 & 1 \\ 0 & 0 & \cdots & 0 & 0 \end{bmatrix} x + \begin{bmatrix} k \\ 0 \end{bmatrix} u, & \beta - \alpha > 0 \end{cases} \quad (3.16b)$$

It is easy to verify that $[B; AB; A^2B; \dots; A^{|\beta-\alpha|-1}B]$ has rank $|\beta-\alpha|$; hence, the state representation (3.16) is completely controllable [7]. By Theorem 8 in [6], the state representation (3.16) is passive if, and only if, the transfer function matrix

$$H(s) \triangleq C(sI-A)^{-1}B + D$$

is positive real. A simple calculation shows that for representation (3.16),

$$H(s) = \begin{cases} \begin{bmatrix} 1 \\ k/s^{\beta-\alpha} \end{bmatrix}, & \beta - \alpha < 0 \\ \begin{bmatrix} 1/s^{\beta-\alpha} \\ k \end{bmatrix}, & \beta - \alpha > 0. \end{cases} \quad (3.17)$$

In either case, $H(s)$ is positive real if, and only if $k \geq 0$ and $|\beta-\alpha| \leq 1$.

Consider now the case $\alpha=1$. The only linear 2-terminal higher-order element that is not active by Theorem 3.2 is when $\beta=0$. The completely-controllable state representation in this case is

$$\dot{x}_1 = ku, \quad \begin{bmatrix} i \\ v \end{bmatrix} = \begin{bmatrix} u \\ x_1 \end{bmatrix},$$

It is easy to show that in this case, the transfer function is just $H(s) = k/s$, which is positive real if, and only if $k > 0$. Therefore invoking Theorem 8 in

[6] again, the higher-order element is passive if, and only if $k > 0$. (For $k = 0$, the element is just a constant voltage source, which is known to be active.)

Theorem 3.4. The only passive elements of the form

$$v = f(i^{(\beta)}) \text{ with } \beta \geq 1 \text{ or } v^{(\alpha)} = f(i) \text{ with } \alpha \geq 1$$

are the linear elements

$$v = ki^{(1)}, \quad k \geq 0$$

and

$$v^{(1)} = ki, \quad k > 0$$

□

Remark. Even though this theorem is a direct consequence of Theorems 3.2 and 3.3, the proof is nevertheless quite complicated and can be found in [3]. A summary of the results for the linear case can be found in Figure 4. The linear elements shown by the solid lines in the fourth quadrant are passive if, and only if $k \geq 0$. Those in the first quadrant are passive under the same condition provided that the initial conditions are constrained to satisfy equation (3.14). The two circles in the circuit-element-array indicate those elements which are passive if, and only if $k > 0$, regardless of the initial condition. □

4. LOSSLESSNESS

An electrical network is lossless if it is incapable of delivering net energy to, or absorbing net energy from the external world. Throughout this section, we shall adopt the state space approach in [8] to study the losslessness of two-terminal higher-order elements. Basically, we treat losslessness as the path-independence of energy consumed while traversing any two points in the state space. The 2-terminal higher-order element that we shall concern ourselves with has the same description as in Section 3 (c.f. equation (3.1)). The following definitions are adapted from [8]:

Definition 4.1. Let S denote the state representation of a higher-order element and let Σ denote the corresponding state space.

a) The energy consumed by the element due to an input waveform $u(\cdot)$ applied over the time interval $[t_1, t_2]$ is defined to be

$$\int_{t_1}^{t_2} i(x(t), u(t)) v(x(t), u(t)) dt .$$

b) S is a lossless state representation if the following condition holds for every pair of states $x_a, x_b \in \Sigma$: The energy consumed is the same for any two input waveforms $u_1(\cdot)$ and $u_2(\cdot)$ applied over the time intervals $[0, T_1]$ and $[0, T_2]$, respectively, that drive the element from initial state x_a to final state x_b . Otherwise, S is not lossless. \square

Definition 4.2. A state representation S is defined to be totally-observable if it satisfies the following conditions:

- (i) S is completely observable [8] and
- (ii) S is input-observable, i.e., to any admissible current-voltage pair $(i(\cdot), v(\cdot))$ associated with a given initial state x_0 , there corresponds exactly one input waveform $u(\cdot)$. \square

Definition 4.3. The higher-order element is lossless if there exists for this element a totally-observable state-representation S which is lossless by Definition 4.1. Otherwise, the element is not lossless. \square

Remark. Definitions 4.1 and 4.3 distinguish between a lossless state representation and a lossless element. The importance of such a distinction is explained carefully in [7] in which the definitions are formulated for a general nonlinear n -port. While there may exist a lossless state representation for a nonlinear n -port, one cannot simply conclude that the n -port itself is lossless. The difficulty in checking whether or not an n -port is lossless lies in the requirement of the existence of a totally-observable state representation. Input-observability is usually easy to check, since almost all networks of practical interest have this property [8]. However, complete-observability poses a problem, since to the best of our knowledge, there does not exist any criteria for testing this property, except for the case of a linear n -port. It is beyond the scope of this paper to expound on the implications of observability on losslessness. Most of our subsequent results in Theorem 4.1 consist of showing that a 2-terminal higher-order element is not lossless. According to Lemma 3.3 in [8], to show that the element is not lossless, it suffices to find only one input-observable state representation that is not lossless. Since it has already been shown in [3] that every 2-terminal higher-order element $v^{(\alpha)} = f(i^{(\beta)})$ has an input-observable state representation, all that is required would be to show that this representation is not lossless according to Definition 4.2. Theorem 4.2 does not concern the observability issue, as it gives a sufficient condition for the losslessness of the state representations of a specific class of elements; and Theorem 4.3 deals with the linear case in which all that needs to be checked is the complete controllability of the state representation [8]. \square

Theorem 4.1. If $f: \mathbb{R} \rightarrow \mathbb{R}$ is piecewise-continuous,⁷ and, depending on the integer values of α and β , satisfies the conditions in Table 2, then the 2-terminal higher-order element described by $v^{(\alpha)} = f(i^{(\beta)})$ is not lossless. \square

Remarks. For the case ($\alpha \geq 1, \beta \geq 1$) the restriction on f is satisfied by a large class of piecewise-continuous functions; in particular, this includes all linear and odd functions. Note that in this case, all the elements $v^{(\alpha)} = f(i^{(\beta)})$ which are not lossless are also active, according to Theorem 3.2.

For ($\alpha \geq 1, \beta = 0$), the criterion for non-losslessness and activity are identical; hence we can conclude that all active elements falling in this category are not lossless, and vice-versa.

The restrictions on f in the case ($\alpha = 0, \beta \leq -2$) can be satisfied by almost any non-trivial piecewise-continuous function. In particular, the linear element $v = ki^{(\beta)}$ for any even, negative value of β is not lossless. Also, by comparison with Theorem 3.2, almost all 2-terminal higher-order elements that are not lossless are active.

The above observations may lead us to believe that only passive 2-terminal higher-order element can be lossless. However, as will be apparent in Theorems 4.2 and 4.3, this is not always the case. In fact, it is worthwhile to point out here that traditionally, losslessness has been studied only for the case of passive n-ports. One novel feature in our present definition of losslessness is that it allows for the consideration of losslessness even for active n-ports.

Just as its counterpart in Section 3, the proof of this theorem consists of a case by case analysis of the different (input-observable) state representations for the element, depending on the values of α and β . We drive the system with a cyclic input waveform and show that in one period T , the energy consumed from an initial state $x(0)$ to final state $x(T) = x(0)$ is nonzero. Repeating this input for another period, the energy consumed is twice the amount of that concerned in the first cycle. Since different amounts of energy are consumed along two different trajectories in the state space having the same initial and final state, we can conclude that the element is not active. The details of this proof can be found in [3]. \square

Theorem 4.2. If f is piecewise continuous when $\alpha \geq 0$, and $f \in C^{|\alpha|}$ when $\alpha \leq -1$, the 2-terminal higher-order element $v^{(\alpha)} = f(i^{(\beta)})$ with $\alpha + \beta = -1$ has a lossless

⁷This condition can be relaxed, as shown in [3], but for the sake of brevity, we shall not dwell on technical details.

state representation. □

Proof. The basic idea behind the proof is to show that the energy consumed during the time interval $[t_1, t_2]$ is dependent only on the initial state $x(t_1)$ and final state $x(t_2)$.

a) For $\alpha = 0, \beta = -1$: The state representation for the 2-terminal higher-order element $v^{(\alpha)} = f(i^{(\beta)})$ is given by [3]:

$$\dot{x}_1 = u, \quad \begin{bmatrix} i \\ v \end{bmatrix} = \begin{bmatrix} u \\ f(x_1) \end{bmatrix} \quad (4.4)$$

The energy consumed during the interval $[t_1, t_2]$ is

$$\int_{t_1}^{t_2} f(x_1) \dot{x}_1 dt = \int_{x(t_1)}^{x(t_2)} f(x_1) dx_1,$$

which is dependent only on $x_1(t_1)$ and $x_1(t_2)$.

b) For $\alpha \geq 1, \beta = -\alpha - 1$, the state representation is [3]:

$$\left\{ \begin{array}{l} \dot{x}_1 = u \\ \dot{x}_2 = x_1 \\ \vdots \\ \dot{x}_{\alpha+1} = x_\alpha \\ \dot{x}_{\alpha+2} = f(x_{\alpha+1}) \\ \dot{x}_{\alpha+3} = x_{\alpha+2} \\ \vdots \\ \dot{x}_{2\alpha+1} = x_{2\alpha} \end{array} \right\}, \quad \begin{bmatrix} i \\ v \end{bmatrix} = \begin{bmatrix} u \\ x_{2\alpha+1} \end{bmatrix}, \quad (4.5)$$

Consider the energy consumed in $[t_1, t_2]$:

$$\int_{t_1}^{t_2} i v dt = \int_{i^{(-1)}(t_1)}^{i^{(-1)}(t_2)} v di^{(-1)}$$

Using integration by parts recursively on the right side of the integral, we get

$$\int_{t_1}^{t_2} i(t) v(t) dt = \sum_{p=1}^{\alpha} [(-1)^{p-1} v^{(p-1)}(t) i^{(-p)}(t)]_{t_1}^{t_2} + \int_{i^{(-\alpha-1)}(t_1)}^{i^{(-\alpha-1)}(t_2)} v^{(\alpha)} di^{(-\alpha-1)}$$

Each term in the summation on the right side of the above equation is just a product of the state components (c.f. equation (4.5)) evaluated at initial time t_1 and final time t_2 . The integral on the right side can be rewritten as

$$\int_{i^{(-\alpha-1)}(t_1)}^{i^{(-\alpha-1)}(t_2)} f(i^{(-\alpha-1)}) di^{(-\alpha-1)},$$

which is a function only of the $(\alpha+1)$ -th state component evaluated at t_1 and t_2 . Hence the energy consumed as the state trajectory traverses from initial state $x(t_1)$ to final state $x(t_2)$ is dependent only on the endpoints. By Definition (4.2), the state representation (4.5) is lossless.

c) For $\alpha \leq -1$, $\beta = -\alpha-1$, the state representation for the element is [3]:

$$\left\{ \begin{array}{l} \dot{x}_1 = u \\ \dot{x}_2 = x_1 \\ \vdots \\ \dot{x}_{2|\alpha|-1} = x_{2|\alpha|-1} \end{array} \right\}, \quad \begin{bmatrix} i \\ v \end{bmatrix} = \begin{bmatrix} x_{2|\alpha|-1} \\ \tilde{f}(u, x_1, \dots, x_{|\alpha|}) \end{bmatrix}, \quad (4.6a)$$

where $\tilde{f}: \mathbb{R}^{|\alpha|+1} \rightarrow \mathbb{R}$ is defined to be

$$\tilde{f}(u, x_1, \dots, x_{|\alpha|}) \triangleq \left. \frac{d^{|\alpha|}}{dt^{|\alpha|}} f(z) \right|_{z=i^{(\beta)}=x_{|\alpha|}} \quad (4.6b)$$

By applying integration-by-parts recursively as in part b) above, the energy consumed within time interval $[t_1, t_2]$ is

$$\sum_{p=1}^{|\alpha|} \left[(-1)^{p-1} i^{(p-1)}(t) v^{(-p)}(t) \right]_{t_1}^{t_2} + \int_{i^{(-\alpha-1)}(t_1)}^{i^{(-\alpha-1)}(t_2)} f(i^{(-\alpha-1)}) di^{(-\alpha-1)} \quad (4.7)$$

It is easy to verify that for $p = 1, \dots, |\alpha|$, $v^{(-p)}(t)$ is dependent only on $x_1(t), \dots, x_{|\alpha|}(t)$. Hence, by comparison with state representation (4.6a), expression (4.7) is found to be dependent only on the initial state $x(t_1)$ and the final state $x(t_2)$. Thus the state representation is lossless. \square

Remark. Theorem 4.2 states that any 2-terminal higher-order element $v^{(\alpha)} = f(i^{(\beta)})$ lying on the -45° line in the circuit-element-array shown in Figure 5 has a

lossless state representation. Notice that the charge-controlled capacitor $((\alpha, \beta) = (0, -1))$ and the current-controlled inductor $((\alpha, \beta) = (-1, 0))$ both fall under the consideration of this theorem. \square

Theorem 4.3. Consider a linear higher-order element described by equation (3.13) and belonging to the class P_L (c.f. equation (3.14) in Theorem 3.3). The linear element is lossless if, and only if, $k = 0$, or $|\beta - \alpha|$ is odd. \square

Proof.

a) For $k = 0$, all elements in class P_L satisfy $i(t) = v(t) = 0$, for all $t \geq 0$. Hence it is obviously lossless.

b) Suppose $k \neq 0$, using exactly the same techniques as in the proof of Theorem 3.3, we can show that all linear elements belonging to class P_L have a completely controllable state representation with transfer function matrix

$$H(s) = \begin{bmatrix} 1 \\ k/s^{\beta-\alpha} \end{bmatrix}, \begin{bmatrix} 1/s^{\beta-\alpha} \\ k \end{bmatrix}, \text{ or } k/s.$$

(c.f. equation (3.12)). By Theorem (5.1) in [8], the element is lossless iff $H(j\omega) = -H(j\omega)$. Clearly, this condition is satisfied for $H(s)$ in this case if, and only if $|\beta - \alpha|$ is odd.

Remark. The conclusion of this theorem is in agreement with Theorem 4.2 for the case $(\alpha \geq 1, \beta = 0)$. However, for $(\alpha \geq 1, \beta \geq 1)$, Theorem 4.2 states that all linear elements with $\alpha \geq 1, \beta \geq 1$ can never be lossless. We must, once again, draw the distinction between the unconstrained elements and constrained elements. The present result holds only for those elements whose initial conditions satisfy condition (3.14). This is not surprising, because the higher-order elements belonging in the class P_L and satisfying condition (ii) in Theorem 4.3 are precisely those which behave like inductors and capacitors, and should therefore be lossless. Another distinguishing feature of this result is that even negative linear capacitors and inductors are classified as lossless elements. Since such elements are active, they have not even been considered in classical circuit theory in the context of losslessness. The lossless 2-terminal linear higher-order elements in class P_L are depicted in Figure 6. Note that this includes the passive elements of the same class, as shown in Figure 4.

5. CONCLUDING REMARKS

So far, we have derived necessary and sufficient conditions for reciprocity of a higher- or mixed-order n -port element, and sufficient conditions for passivity and losslessness of 2-terminal higher-order elements. For a subclass, namely P_L , of linear 2-terminal higher-order elements, we have derived both necessary and sufficient conditions for passivity and losslessness.

Theorem 3.1 states that a large class of 2-terminal higher-order elements of the form $v^{(\alpha)} = f(i^{(\beta)})$ are active. In fact, provided that f satisfies certain minor restrictions, the only nonlinear candidates for passivity are the elements that lie in the region shown in Figure 2. In Example 3.3, we have identified a passive higher-order element that is different from the conventional circuit elements. The problem of finding sufficient passivity conditions for nonlinear elements in this region still remains open. One interesting feature of the elements in this region is that any (α, β) -element behaves like a time-varying linear $(\alpha-1, \beta-1)$ -element (for $\alpha, \beta \leq -1$) whose time-varying parameter depends on the signal waveforms.

Even though losslessness in the linear case has been covered thoroughly in Section 4, the results for the nonlinear case are not as complete as their counterparts in Section 3 on passivity. This is inevitable, because unless the subject of nonlinear observability has been further investigated, there exists no systematic method of testing the lossless properties of the rest of the nonlinear higher-order elements. Alternatively, one can attempt to reformulate losslessness as a property that is independent of state representations.

REFERENCES

- [1] L.O. Chua, "Device Modeling via Basic Nonlinear Circuit Elements", IEEE Trans. on Circuits and Systems, Special Issue on Nonlinear Circuits and Systems, Vol. CAS-27, No. 11, Nov. 1980, pp. 1014-1044.
- [2] L.O. Chua and E.W. Szeto, "Synthesis of Higher-order Nonlinear Circuit Elements", Memorandum No. ERL/UCB M82/17, March 5, 1982.
- [3] L.O. Chua and E.W. Szeto, "State Space Properties of Higher-order Nonlinear Circuit Elements", Memorandum No. UCB/ERL M82/18, March 12, 1982.
- [4] L.O. Chua, "Nonlinear Circuit Theory", Proceedings of the 1978 European Conference on Circuit Theory and Design, Vol. II, Guest Lectures, pp. 65-172, September 4-8, 1978.
- [5] S. Duinker, "Traitors, a New Class of Non-energetic Non-Linear Network Elements", Philips Res. Rep. 14, 29-51 (1959).
- [6] J.L. Wyatt, Jr., L.O. Chua, J.W. Gannett, I.C. Goknar and D.N. Green, "Energy Concepts in the State-Space Theory of Nonlinear n-Ports: Part I - Passivity", IEEE Transactions on Circuits and Systems, Vol. CAS-28, No. 1, January 1981.
- [7] P.J. Moylan, L.O. Chua and E.W. Szeto, "When is a Device Passive", International Journal of Circuit Theory and Applications, Vol. 10, February 1982, in press.
- [8] J.L. Wyatt, Jr., L.O. Chua, J.W. Gannett, I.C. Goknar and D.N. Green, "Foundations of Nonlinear Network Theory: Part II - Losslessness," Memorandum No. UCB/ERL M80/3, February 1980.

FIGURE CAPTIONS

- Figure 1: i - $v^{(1)}$ characteristic for the 2-terminal higher-order element of Example 3.1.
- Figure 2: Possible nonlinear passive elements prescribed by Theorem 3.2.
- Figure 3: Synthesis of the (unconstrained) linear higher-order element $v^{(1)} = ki^{(1)}$.
- Figure 4: The passive linear elements in class P_L are those with $k \geq 0$, lying on the solid lines. The two circles represent those linear elements that are passive if, and only if $k > 0$.
- Figure 5: Higher-order elements with lossless state representations.
- Figure 6: The lossless linear elements in class P_L are represented by the solid lines.

	α	β	f
a	≥ 1	≥ 1	no restrictions
b	≥ 1	$= 0$	$\exists a, b \in \mathbb{R}$ such that $\begin{cases} \text{(i) } ab < 0, \text{ and} \\ \text{(ii) } af(b) \neq bf(a) \end{cases}$
c	≥ 1	$= -1$	\exists integer k and $A_j \in \mathbb{R}$ for $j = 0, 1, \dots, k$, such that $f(z) \leq \sum_{j=0}^k A_j z^j \forall z \in [0, \infty)$ or $(-\infty, 0]$.
d	≥ 0	≤ -2	$\exists a \in \mathbb{R}$ such that $f(a) \neq 0$
e	≤ -1	$\leq \alpha - 2$	$\exists a \in \mathbb{R}^{ \alpha +1}$ such that $\left. \frac{d^{ \alpha }}{dt^{ \alpha }} f(i(\beta)) \right _a \neq 0$
f	$\leq \beta - 2$	≤ -1	$\exists a \in \mathbb{R}$ such that $\left. \frac{d}{dz} f(z) \right _{z=a} \neq 0$
g	≤ -2	≥ 1	
h	≤ -2	$= 0$	$\exists a \in \mathbb{R}$ such that $a \left. \frac{d}{dz} f(z) \right _{z=a} \neq 0$
i	$= -1$	≥ 1	$\exists b > 0, M > 0$ such that $\frac{d}{dz} f(z) \geq M \forall z \in [b, \infty)$
j	$= 0$	≥ 1	$\exists a, b \in \mathbb{R}$ such that $\begin{cases} \text{(i) } ab < 0 \text{ and} \\ \text{(ii) } bf(a) \neq af(b) \end{cases}$

Table 1

α	β	f
≥ 1	≥ 1	$\exists a, b \in \mathbb{R}$ such that (i) $ab < 0$, and (ii) $af(b) = bf(a) \neq 0$
≥ 1	$= 0$	$\exists a, b \in \mathbb{R}$ such that (i) $af(b) \neq bf(a)$, and (ii) $f(a)f(b) < 0$
$= 0$	≤ -2 and takes on only even values	$\exists \delta > 0$ such that (i) f is injective and continuous in the interval $[-\delta/2, \delta/2]$, and (ii) $f(x) \neq f(0)$ on a set of nonzero measure $\forall x \in [-\delta/2, \delta/2]$.

Table 2

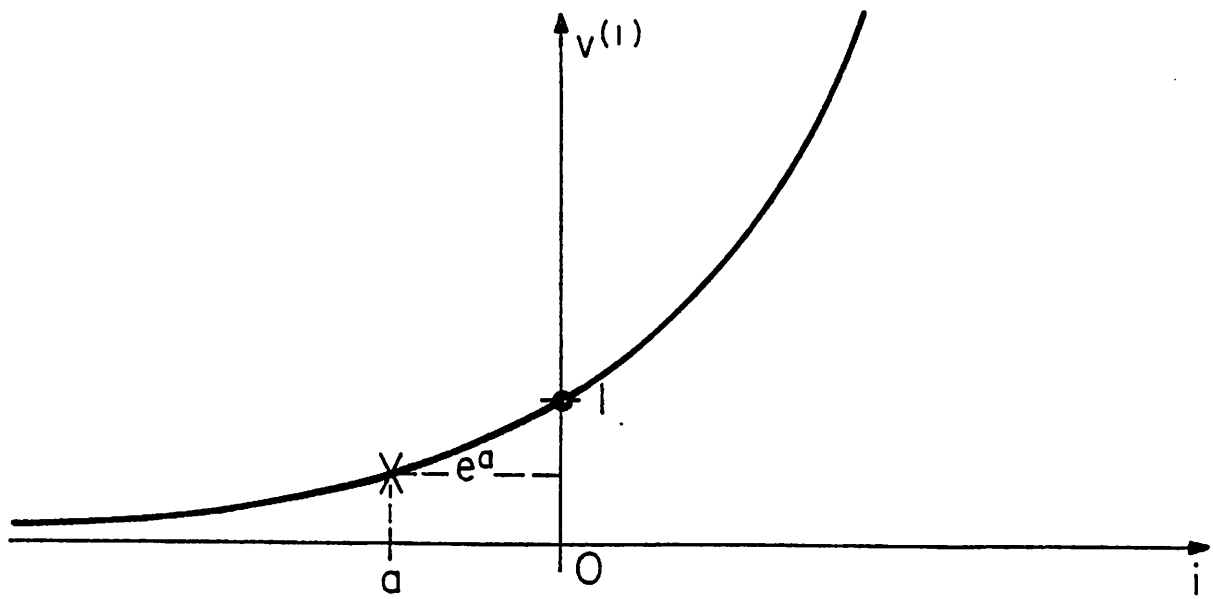

Fig. 1

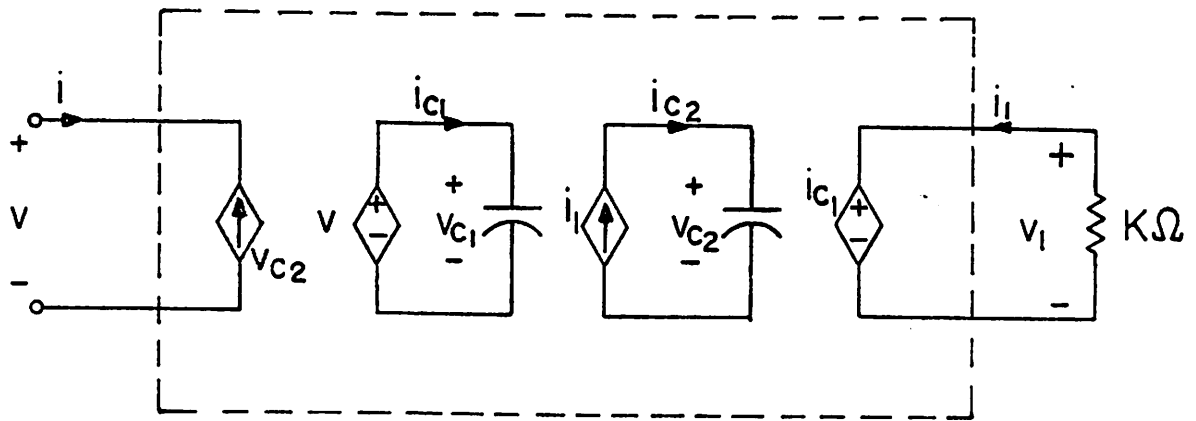

Fig. 3

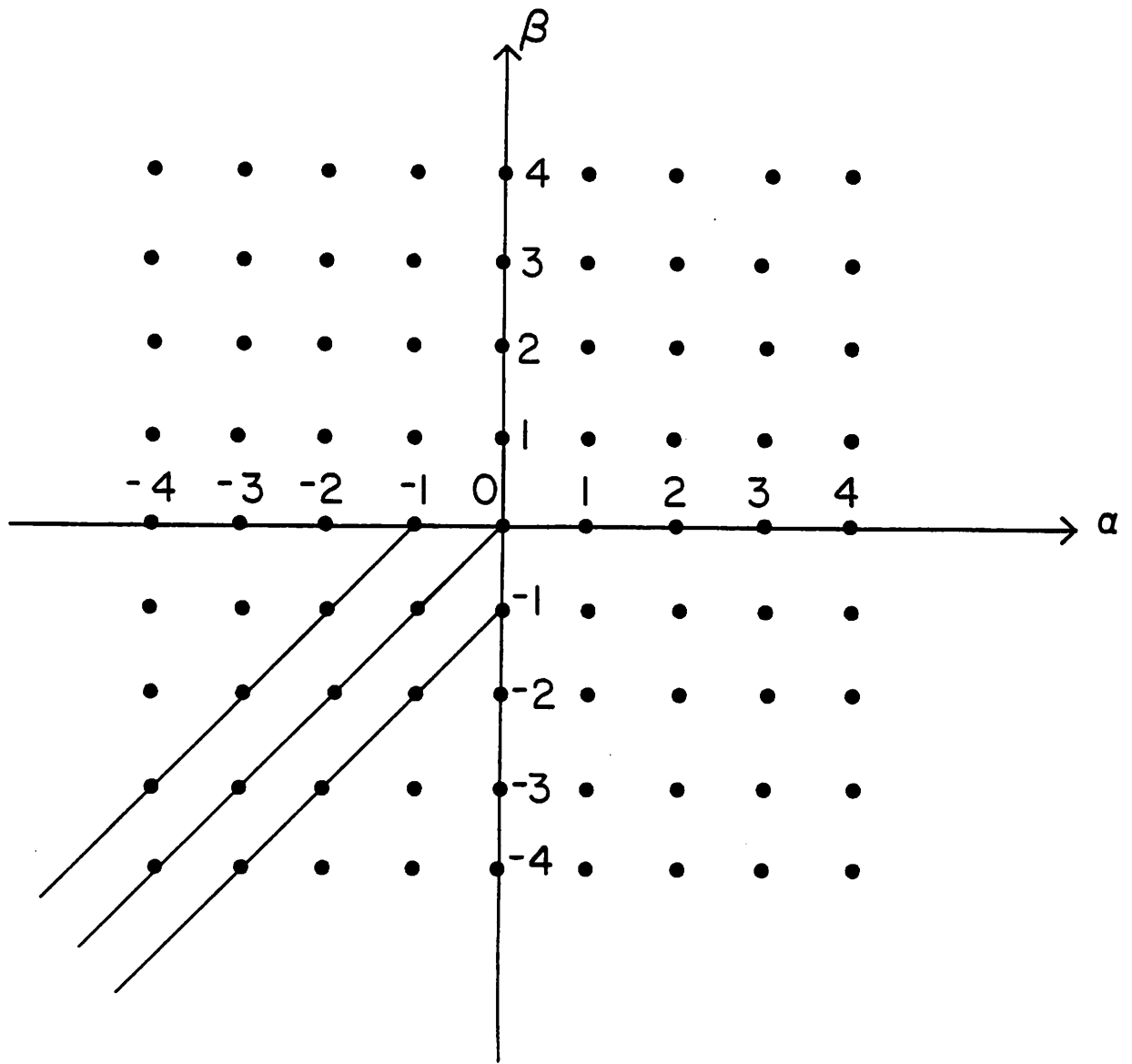

Fig. 2

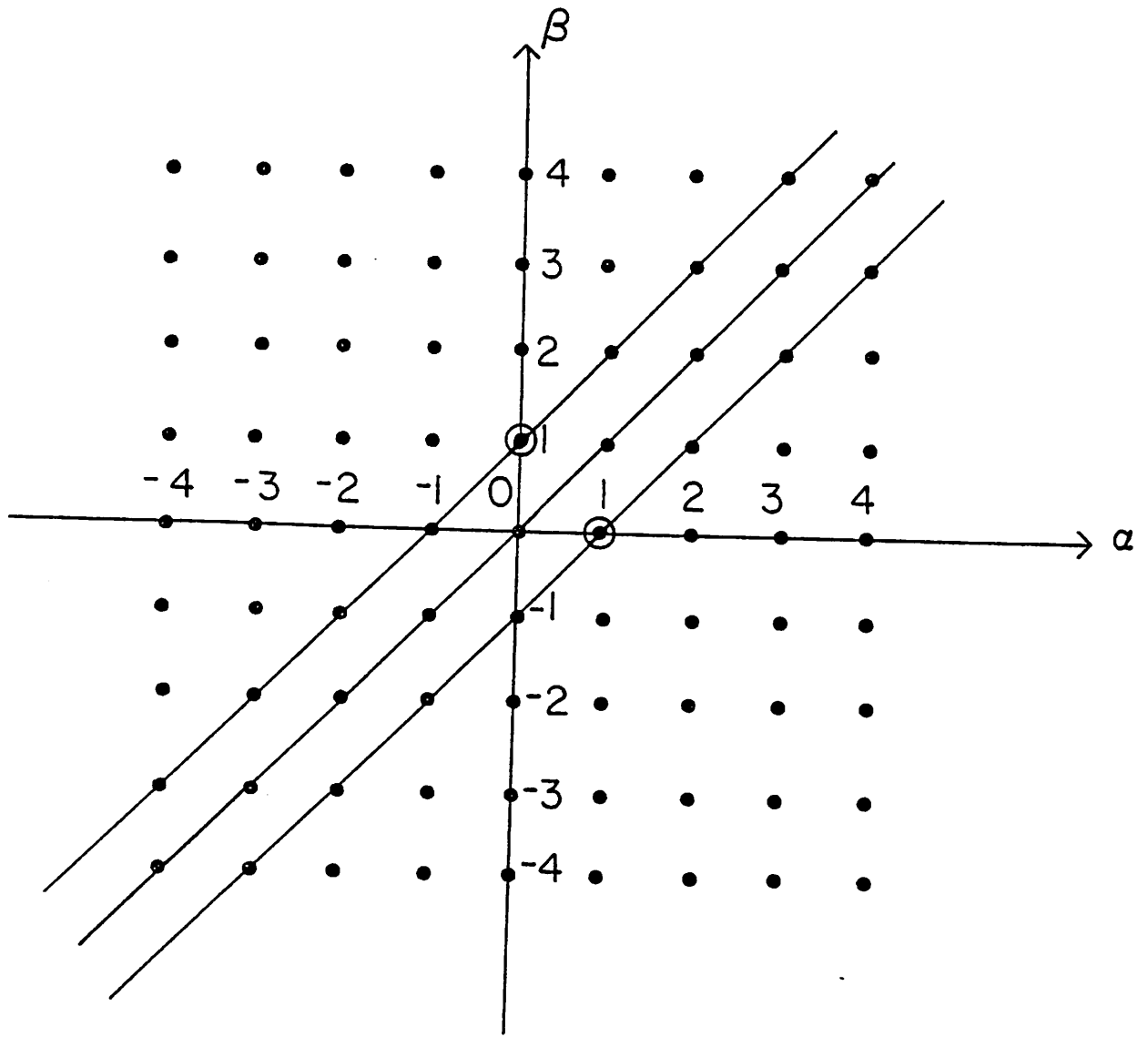

Fig. 4

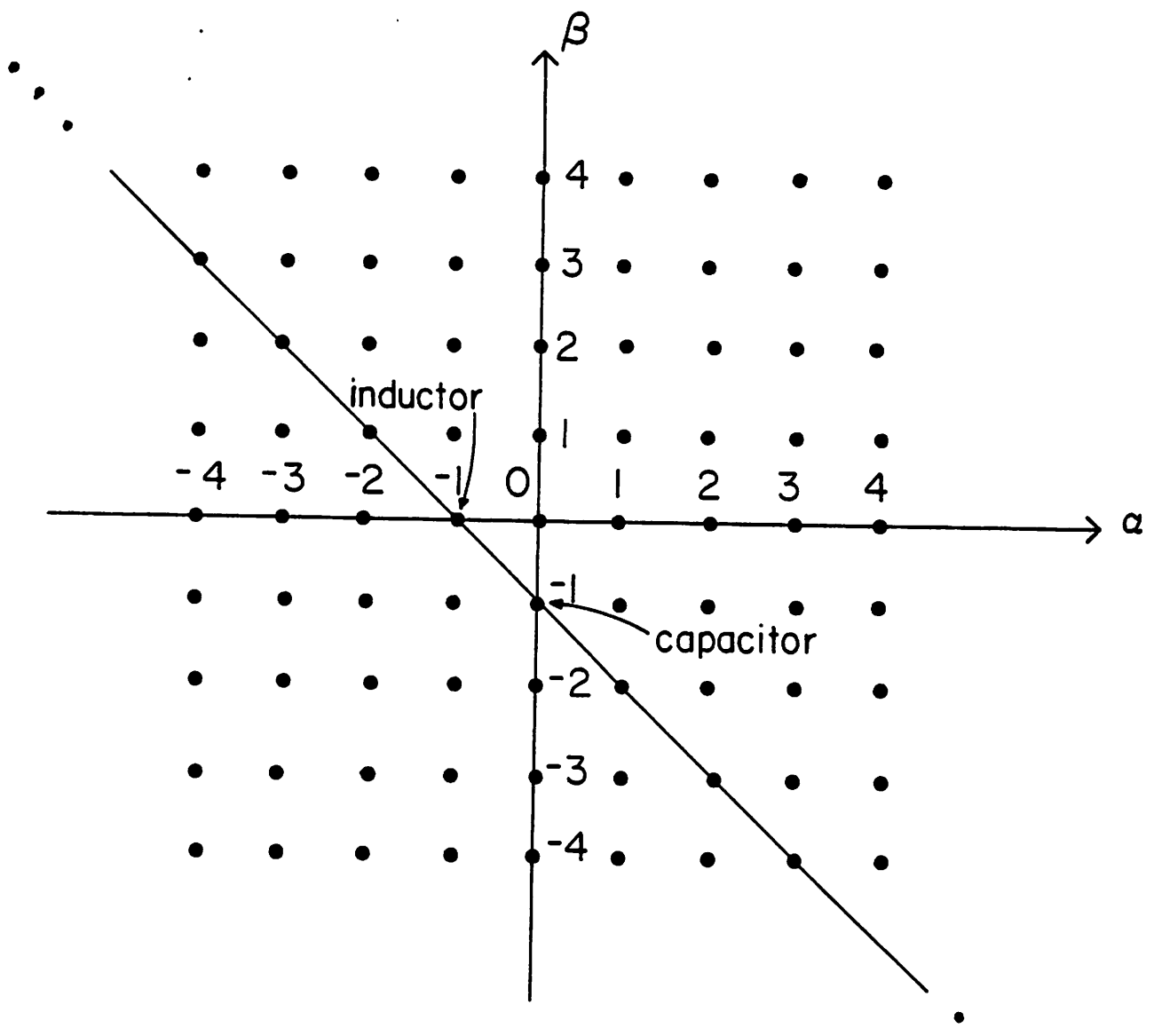

Fig. 5

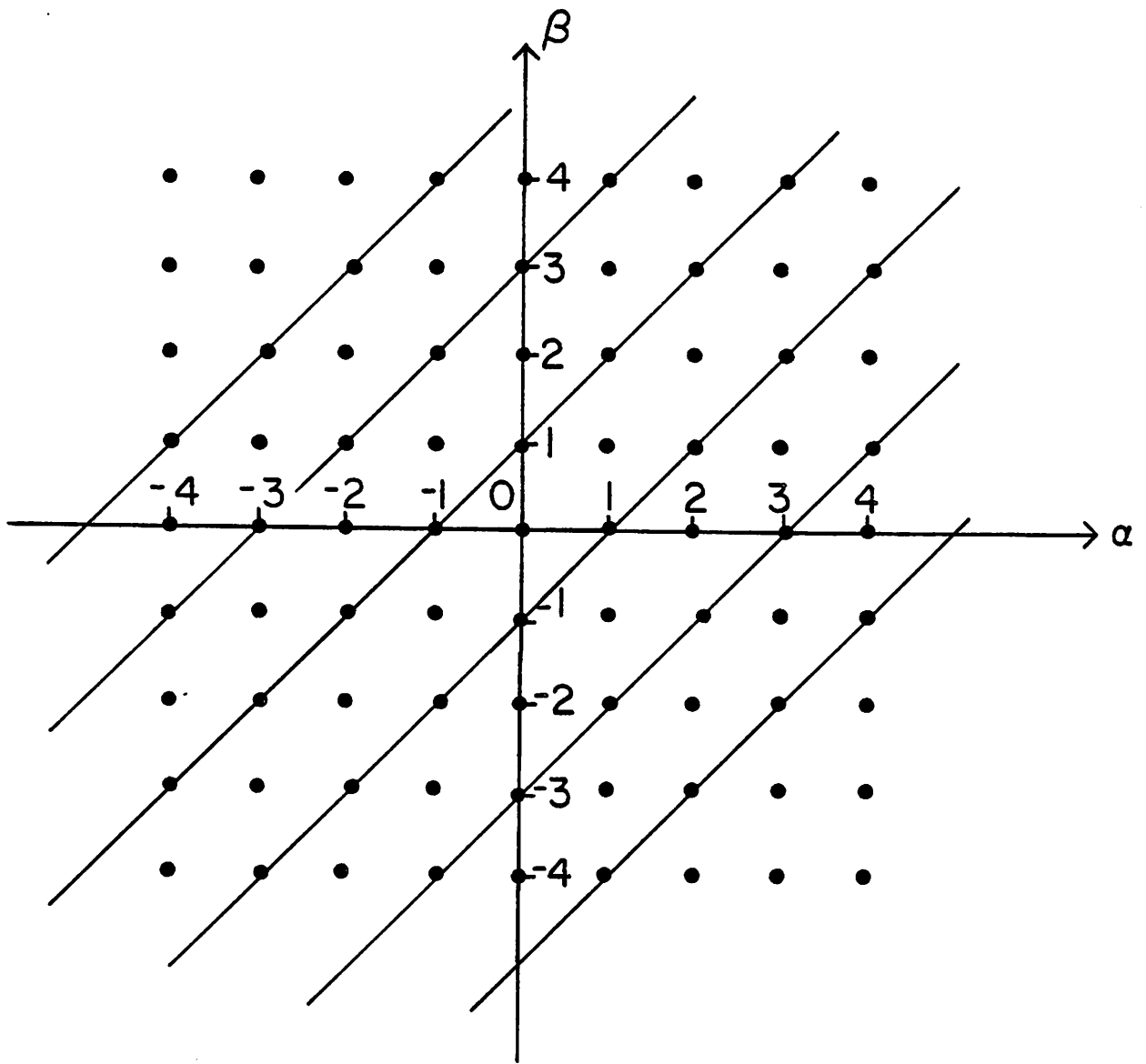

Fig. 6