

Copyright © 1982, by the author(s).
All rights reserved.

Permission to make digital or hard copies of all or part of this work for personal or classroom use is granted without fee provided that copies are not made or distributed for profit or commercial advantage and that copies bear this notice and the full citation on the first page. To copy otherwise, to republish, to post on servers or to redistribute to lists, requires prior specific permission.

ON THE STABILIZATION OF NONLINEAR SYSTEMS

by

V. Anantharam and C. A. Desoer

Memorandum No. UCB/ERL M82/49

6 May 1982

ON THE STABILIZATION OF NONLINEAR SYSTEMS

by

V. Anantharam and C.A. Desoer

Memorandum No. UCB/ERL M82/49

6 May 1982

ELECTRONICS RESEARCH LABORATORY
College of Engineering
University of California, Berkeley
94720

ON THE STABILIZATION OF NONLINEAR SYSTEMS

V. Anantharam and C. A. Desoer

Department of Electrical Engineering and Computer Sciences
 and the Electronics Research Laboratory
 University of California, Berkeley, California 94720

Abstract

We extend the applicability of the global Q-parametrization method of controller design to a large class of unstable nonlinear plants. The main result is a two-step compensation theorem analogous to that of Zames for unstable linear plants — if $P : \mathcal{L}_{e2} \rightarrow \mathcal{L}_{e1}$ is a nonlinear (possibly unstable) plant and F_0 is any incrementally stable controller such that $P_1 := P(I - F_0(-P))^{-1}$ is incrementally stable, then the class of controllers F which yield a f.g. stable closed-loop system in the unity feedback configuration for P , is globally parametrized by finite gain stable maps $Q : \mathcal{L}_{e1} \rightarrow \mathcal{L}_{e2}$ with $F = F_0 + Q(I - P_1 Q)^{-1}$.

I. Introduction

The aim of this paper is to extend the domain of applicability of the Q-parametrization design theorem for nonlinear systems. The well known Q-parametrization theorem states that for a stable plant P, a compensator F yields a stable closed loop (see Fig. 1) if and only if $F = Q(I+PQ)^{-1}$ for some stable Q. This was proved in the linear case by Zames [Zam. 1], and used in design by Desoer and Chen [Des. 1]. In the nonlinear case (where one requires in addition that the plant be incrementally stable) its roots go back to Desoer and Chan [Des. 2], and it has been stated explicitly by Desoer and Liu [Des. 3]. A consequence of this attractively simple parametrization is extreme efficiency in design — indeed, the I/O map is PQ. For example, in the linear case, it has been exploited in [Des. 1] to provide an algorithm for compensator design in the case of rational transfer function matrices. Further, the use of this method in an optimization environment permits efficient design for a closed-loop transfer function which is required to satisfy various complex a priori inequality constraints [Gus. 1].

The Q-parametrization method requires that the plant be stable. This is a direct consequence of the algebraic nature of the result — in fact it can be formulated in an abstract algebraic context [Des. 1], [Des. 4], [Ana. 1]. Because of the existence of a number of applications where the plant is unstable (airplanes, chemical reactions,.....), it is of interest to extend the method to a larger class of plants. For linear plants, results in this direction have been obtained by Zames [Zam. 2] Zames considers the class of all plants which are stabilizable by stable compensators. These are the strongly stabilizable ones [You. 1]. (It may be shown by the methods of [Des. 4] that this class includes the stable plants.) It is shown in [Zam. 2] that by a 2-step compensation

scheme one may exploit the Q-parametrization results to design for the closed-loop transfer function for a strongly stabilizable plant.

This paper may be considered the nonlinear version of [Zam. 2]. After defining strong stabilizability suitably in the nonlinear context, we exhibit how design of the closed-loop system for a strongly stabilizable nonlinear plant may be carried out by a 2-step scheme, where the latter employs the nonlinear Q-parametrization result. Some results pertaining to the robustness of stability of the closed loop, in the spirit of the model reference scheme results of [Zam. 2], are also presented.

The organization of the paper is as follows: Section II presents some standard definitions and notation for the concepts used. The main results are present in Sec. III and proved in Appendix I. Section IV is a short summary and is followed by the list of references.

II. Preliminaries

$a := b$ means "a denotes b." Let $\mathbb{R} :=$ the field of real numbers. We consider systems whose inputs, outputs, etc. are defined on $T \subseteq \mathbb{R}$, typically $T = \mathbb{R}_+$ or $T = \mathbb{Z}_+$. For V any normed space let $F := \{f : T \rightarrow V\}$, with norm $\|\cdot\|_F$. Typically $V = \mathbb{R}^n$. For any $\tau \in T$ and $f \in F$, let $f_\tau \in F$ be defined by

$$\begin{aligned} f_\tau(t) &= f(t) & \text{if } t \leq \tau \\ &= 0 & \text{if } t > \tau \end{aligned}$$

Let $\|f\|_\tau := \|f_\tau\|_F$ and $P_\tau : F \rightarrow F$ be such that $P_\tau f = f_\tau$. Using usual operations of addition and scalar multiplication, we may define vector spaces of the type

$$\mathcal{L}_e := \{f \in F \mid \forall \tau \in T, \|f\|_\tau < \infty\}$$

Let $H : \mathcal{L}_{e1} \rightarrow \mathcal{L}_{e2}$. We say H is causal iff $\forall \tau \in T$ we have $P_\tau H P_\tau = P_\tau H$. All maps encountered in this paper will be causal.

Let $H : \mathcal{L}_{e1} \rightarrow \mathcal{L}_{e2}$ be causal. We say H is finite-gain stable (f.g. stable) iff $\exists \gamma(H) < \infty$ such that

$$\|Hx\|_\tau \leq \gamma(H) \|x\|_\tau, \quad \forall \tau \in T, \forall x \in \mathcal{L}_{e1}$$

Let $H : \mathcal{L}_{e1} \rightarrow \mathcal{L}_{e2}$ be f.g. stable. Then, we say H is incrementally stable (inc.stable) iff $\exists \tilde{\gamma}(H) < \infty$ such that

$$\|Hx - Hy\|_\tau \leq \tilde{\gamma}(H) \|x - y\|_\tau \quad \forall \tau \in T \quad \forall x, y \in \mathcal{L}_{e1}$$

We consider feedback systems of the type shown in Fig. 1.

The input (output, error) space of such a system, denoted $U, (Y, E)$, is the Cartesian product of the spaces of the individual inputs (outputs, errors, resp). We say that a feedback system is well posed iff it defines causal (closed-loop) maps: $H_{YU} : U \rightarrow Y$ and $H_{EU} : U \rightarrow E$. (For the system 'S(P,F) in Fig. 1, $H_{YU} : (u_1, u_2) \mapsto (y_1, y_2)$ and $H_{EU} : (u_1, u_2) \mapsto (e_1, e_2)$). We assume throughout that the systems we consider are well posed.

We say a system is finite gain stable iff H_{YU} and H_{EU} are f.g. stable maps.

III. Main results

We first state the Q-parametrization theorem for nonlinear systems. For a proof see [Des. 3].

Theorem 1 (Global parametrization of I/O maps)

Consider the system 'S(P,F) shown in Fig. 1, where $P : \mathcal{L}_{e2} \rightarrow \mathcal{L}_{e1}$, $F : \mathcal{L}_{e1} \rightarrow \mathcal{L}_{e2}$. Assume 'S(P,F) is well posed. If P is inc. stable then

$$\textcircled{a} \quad 'S(P,F) \text{ is f.g. stable} \quad (3.1)$$

\Leftrightarrow

for some f.g. stable $Q : \mathcal{L}_{e1} \rightarrow \mathcal{L}_{e2}$

$$F = Q(I-PQ)^{-1} \quad (3.2)$$

\textcircled{b} Furthermore, in terms of P and F

$$Q = F(I+PF)^{-1} = H_{e1}u_1 \quad (3.3)$$

\textcircled{c} With $u_2 = 0$

$$H_{y2}u_1 = PQ. \quad (3.4)$$

Remarks

\textcircled{a} From (3.3), $(I-PQ)^{-1} = (I+PF) : \mathcal{L}_{e1} \rightarrow \mathcal{L}_{e1}$. Further, (3.3) shows that the f.g. stability of $'S(P,F)$, ($H_{e1}u_1$ in particular) requires that Q be f.g. stable.

\textcircled{b} The eqn. $H_{y2}u_1 = PQ$ gives a global parametrization of all I/O maps $u_1 \mapsto y_2$ achievable from a given incrementally stable plant P with the configuration of $'S(P,F)$. This raises the following fundamental problem: given the inc. stable map $P : \mathcal{L}_{e2} \rightarrow \mathcal{L}_{e1}$ write it as the composition of two maps

$$P = \overset{v}{P} P_S$$

where $P_S : \mathcal{L}_{e2} \rightarrow \mathcal{L}_{e2}$ has a f.g. stable causal inverse P_S^{-1} and $\overset{v}{P} : \mathcal{L}_{e2} \rightarrow \mathcal{L}_{e1}$. If one could extract from P its "minimal" $\overset{v}{P}$, we could state that all input-output maps achievable from P by the configuration $'S(P,F)$ are of the form

$$H_{y2}u_1 = \overset{v}{P} M$$

where $M : \mathcal{L}_{e1} \rightarrow \mathcal{L}_{e2}$ is f.g. stable.

Our next result is a partial extension of the nonlinear Q-parametrization theorem to f.g. stable, but not necessarily inc. stable plants. It is essentially a restatement of the small gain theorem (see e.g. [Des. 5]) but has useful design implications. The proof is in Appendix I.

Theorem 2. (Robustness of stability)

Consider the feedback system $'S(P_b, F)$, where P_b is inc. stable and $F = Q(I - P_b Q)^{-1}$ for some f.g. stable Q . Consider a perturbation of P_b :

$$P = P_b + \Delta P, \text{ with } \Delta P \text{ f.g. stable} \quad (3.5)$$

Then

$$\gamma(\Delta P)\gamma(Q) < 1 \quad (3.6)$$

$$\Rightarrow 'S(P, F) \text{ is f.g. stable.} \quad (3.7)$$

Remarks:

(a) Thus, for a f.g. stable, but not necessarily incrementally stable nonlinear plant P , design would proceed by first finding a norm-close incrementally stable approximation P_b and designing for $'S(P_b, F)$ with the constraint $\gamma(P - P_b)\gamma(Q) < 1$ imposed on Q .

(b) For a weakly nonlinear f.g. stable plant P , i.e. one having a norm-close stable linear approximation P_b , linear design methods could be applied with the constraint $\gamma(P - P_b)\gamma(Q) < 1$ on Q .

We next proceed in the spirit of [Zam. 2], to develop a two-step scheme for the design of closed-loop systems involving a class of plants larger than the incrementally stable ones.

Definition: A nonlinear plant $P : \mathcal{L}_{e2} \rightarrow \mathcal{L}_{e1}$ is said to be strongly stabilizable if there is an inc. stable $F_0 : \mathcal{L}_{e1} \rightarrow \mathcal{L}_{e2}$, such that with (see Fig. 2a)

$$P_1 = P(I - F_0(-P))^{-1} \quad (3.8)$$

we have

$$\textcircled{a} \quad 'S(P, F_0) \text{ is f.g. stable} \quad (3.9)$$

$$\textcircled{b} \quad P_1 \text{ is inc. stable.} \quad (3.10)$$

Obviously any incrementally stable plant P is strongly stabilizable.

The proof of the following theorem, which deals with strongly stabilizable nonlinear plants, may be found in Appendix I.

Theorem 3. (Two-step compensation)

Let the nonlinear plant $P : \mathcal{L}_{e2} \rightarrow \mathcal{L}_{e1}$ be strongly stabilizable, and let $F_0 : \mathcal{L}_{e1} \rightarrow \mathcal{L}_{e2}$, be inc. stable such that with

$$P_1 = P(I - F_0(-P))^{-1} \quad (3.8)$$

the conditions (3.9) and (3.10) hold.

Then, (see Fig. 1(b) and 1(c)),

$$'S(P, F) \text{ is f.g. stable for some } F : \mathcal{L}_{e1} \rightarrow \mathcal{L}_{e2} \quad (3.11)$$

\Leftrightarrow

$$'S(P_1, F - F_0) \text{ is f.g. stable for some } F - F_0 : \mathcal{L}_{e1} \rightarrow \mathcal{L}_{e2} \quad (3.12)$$

\Leftrightarrow

there is a f.g. stable Q such that

$$F - F_0 = Q(I - P_1 Q)^{-1} \quad (3.13)$$

yields

$${}^2S(P, F_0, F - F_0) \text{ is f.g. stable.} \quad (3.14)$$

Remarks

\textcircled{a} The claims of this theorem are highly non-obvious and interesting from a design-viewpoint. It says that any causal nonlinear controller F stabilizing a strongly stabilizable nonlinear plant P can be obtained by a two-step process: First, we use any incrementally stable F_0 which

yields (3.9) and (3.10) for $P_1 := P(I - F_0(-P))^{-1}$. Then, using Q-parametrization, we design the compensator $(F - F_0)$ for the inc. stable P_1 , see (3.13).

(b) The theorem gives a global parametrization of all stabilizing compensators F for a strongly stabilizable nonlinear plant. Obviously one needs to build only $'S(P, F)$ with

$$F = F_0 + Q(I - P_1 Q)^{-1}$$

where Q ranges over the f.g. stable maps from \mathcal{L}_{e1} to \mathcal{L}_{e2} .

(c) Since we are handling nonlinear systems we have to be very careful about signs: in general we cannot write

$$I - F_0(-P) = I + F_0 P$$

This equality holds if F_0 is odd, i.e. if

$$F_0(x) = -F_0(-x) \quad \forall x \in \mathcal{L}_{e1}$$

(d) This is a powerful generalization of the corresponding linear theorem of [Zam. 2].

IV. Summary

We point out some of the interesting problems and issues raised by our results:

(1) Given a causal map $P: \mathcal{L}_{e2} \rightarrow \mathcal{L}_{e1}$, how does one "factor" it as $P = \check{P} P_s$ where P_s is causally invertible and \check{P} is the minimal "bad" part of P in some appropriate sense? (This was mentioned in the remarks after Theorem 3). By analogy with fractional representation theory for linear plants (both lumped and distributed), \check{P} would correspond, very loosely, to the "unstable zeros" of P , which, as is well known, impose a fundamental limitation on the class of achievable input-output maps in linear problems. [Per 1, Che 1].

② How does one recognize if a given P is strongly stabilizable?

For linear time-invariant lumped systems an extremely elegant and easily verifiable characterization is available in [You 1], the necessary and sufficient condition for strong stabilizability being that the blocking zeros and the poles of P on the positive real axis satisfy a "parity interlacing property". Is a comparably efficient characterization possible for nonlinear maps? Further, arguing by analogy with the linear case, is it possible to show that the class of strongly stabilizable plants is generic in an appropriate sense?

③ Is there any easy way to find some F_0 which works to strongly stabilize a given map P ? Note that it is sufficient that any inc. stable F_0 satisfying (3.9) and (3.10) be available -- design requirements may be met subsequently by the use of the Q -parametrization method.

We believe that the answers to questions such as these are of fundamental importance to the understanding of the behavior of nonlinear feedback systems from the I/O point of view.

References

- [Ana 1] Anantharam, V. and Desoer, C.A., "Fractional representation theory for nonlinear systems". Work in progress.
- [Che 1] Cheng, V.H.L., and Desoer, C.A., "Limitations on the closed-loop transfer function due to right-half plane transmission zeroes of the plant", IEEE Trans. AC-25,6, p. 1218-1220, Dec. 1980.
- [Des 1] Desoer, C.A. and Chen, M.J., "Design of Multivariable Feedback Systems with Stable Plant", IEEE T-AC, Vol. AC-26, No. 2, April 1981, pp. 408-414.
- [Des 2] Desoer, C.A. and Chan, W.S., "The Feedback Interconnection of Multivariable Systems: Simplifying Theorems for Stability", Proc. IEEE, Vol. 64, No. 1, Jan 1976, pp. 139-144.
- [Des 3] Desoer, C.A. and Liu, R.W. "Global parametrization of feedback systems" Memo No: UCB/ERL M81/57, 24th July, 1981.
- [Des 4] Desoer, C.A., Liu, R.W., Murray, J., and Saeks, R., "Feedback System Design: The Fractional Representation Approach to Analysis and Synthesis", IEEE T-AC, Vol. AC-25, No. 3, June 1980, pp. 399-412.
- [Des 5] Desoer, C.A. and Vidyasagar, M., "Feedback Systems: Input-Output Properties", Academic Press 1975, p. 40.
- [Gus 1] Gustafson, C.L. and Desoer, C.A., "Controller design for Linear Multivariable Feedback Systems with Stable Plants, Using Optimization with Inequality Constraints", Memo No. UCB/ERL M 81/51, 14th July, 1981, to appear in IEEE Trans. on Circuits and Systems.

- [Per 1] Pernebo, L. "An algebraic theory for the design of controllers of Linear Multivariable systems - Part II", IEEE Trans. AC-26, 1, p. 183-193, Feb. 1981.
- [You 1] Youla, D.C., Bongiorno, Jr., J.J., and Lu, C.N., "Single Loop Feedback Stabilization of Linear Multivariable Dynamical Plants", Automatica, Vol. 10, Mar. 1974, pp. 159-173.
- [Zam 1] Zames, G, "Feedback and Optimal sensitivity: Reference Transformations, Weighted Seminorms and Approximate Inverses", Report, Dept. of EE, McGill University, June 1979.
- [Zam 2] Zames, G., "Feedback and Optimal Sensitivity: Model Reference Transformations, Multiplicative Seminorms and Approximate Inverses", IEEE T-AC, Vol. AC-26, No. 2, April, 1981, pp. 301-320.

List of Figure Captions

- Fig. 1. a) defines the system $S(P, F)$.
b) defines the system $^1S(P_1, F - F_0)$
c) defines the system $^2S(P, F_0, F - F_0)$.
d) interprets the relation between P_1 and P and F_0

APPENDIX I

Proof of Theorem 2

The eqns. describing 'S(P,F) read

$$e_1 = u_1 - Pe_2 \quad (A1)$$

$$e_2 = u_2 + Fe_1 \quad (A2)$$

Now $P = P_b + \Delta P$, hence (A1) gives $\forall \tau \in T, \forall (u_1, u_2) \in \mathcal{L}_{e_1} \times \mathcal{L}_{e_2}$

$$\|e_1\|_\tau \leq \|u_1\|_\tau + [\gamma(P_b) + \gamma(\Delta P)] \|e_2\|_\tau \quad (A3)$$

Note that, by (3.3), $(I - P_b Q)^{-1} = I + PF : \mathcal{L}_{e_1} \rightarrow \mathcal{L}_{e_2}$, so define

$$\eta := (I - P_b Q)^{-1} e_1$$

and substitute in (A1) and (A2):

$$(I - P_b Q)\eta = u_1 - (P_b + \Delta P)e_2 \quad (A5)$$

$$e_2 = u_2 + Q\eta \quad (A6)$$

From (A6) we have $\forall \tau \in T, \forall (u_1, u_2) \in \mathcal{L}_{e_1} \times \mathcal{L}_{e_2}$

$$\|e_2\|_\tau \leq \|u_2\|_\tau + \gamma(Q) \|\eta\|_\tau \quad (A7)$$

Now using (A6) in (A5) we obtain

$$\eta = u_1 - P_b(u_2 + Q\eta) + P_b Q\eta - \Delta P e_2 \quad (A8)$$

Hence $\forall \tau \in T, \forall (u_1, u_2) \in \mathcal{L}_{e_1} \times \mathcal{L}_{e_2}$

$$\|\eta\|_\tau \leq \|u_1\|_\tau + \tilde{\gamma}(P_b) \|u_2\|_\tau + \gamma(\Delta P) \|e_2\|_\tau \quad (A9)$$

and, using (A7) to eliminate $\|e_2\|_\tau$,

$$\|e_2\|_\tau \leq \gamma(Q) \|u_1\|_\tau + [1 + \gamma(Q) \cdot \tilde{\gamma}(P_b)] \|u_2\|_\tau + \gamma(Q) \gamma(\Delta P) \|e_2\|_\tau \quad (A10)$$

Thus, using assumption (3.6), $\gamma(\Delta P) \cdot \gamma(Q) < 1$, we conclude that

$$\forall \tau \in T, \forall (u_1, u_2) \in \mathcal{L}_{e_1} \times \mathcal{L}_{e_2}$$

$$\|\dot{e}_2\|_\tau \leq (I - \gamma(Q)\gamma(\Delta P))^{-1} [\gamma(Q) \|u_1\|_\tau + (1 + \gamma(Q) \tilde{\gamma}(P_b)) \|u_2\|_\tau], \quad (A11)$$

thus $(u_1, u_2) \mapsto e_2$ is f.g. stable. Furthermore (A11) and (A3) show that $(u_1, u_2) \mapsto e_1$ is also f.g. stable, hence H_{eu} is f.g. stable.

Now, since $y_1 = e_2 - u_2$ and $y_2 = u_1 + e_1$, it follows that H_{yu} is also f.g. stable. Thus 'S(P,F) is f.g. stable for all f.g. stable ΔP satisfying $\gamma(\Delta P) \gamma(Q) < 1$. □

Proof of Theorem 3.

Consider Fig. 1 and write the summing node equations of the systems diagrammed there

'S(P,F):

$$e_1 = u_1 - Pe_2 \quad (B1)$$

$$e_2 = u_2 + Fe_1 \quad (B2)$$

'S(P₁,F-F₀):

$$\tilde{e}_1 = \tilde{u}_1 - P_1\tilde{e}_2 \quad (B3)$$

$$\tilde{e}_2 = \tilde{u}_2 + (F-F_0)\tilde{e}_1 \quad (B4)$$

where $P_1 := P(I-F_0(-P))^{-1}$ (B5)

²S(P₁, F₀, F-F₀):

$$\hat{e}_1 = \hat{u}_1 - P\hat{e}_2 \quad (B6)$$

$$\hat{e}_2 = \hat{u}_2 + (F-F_0)\hat{e}_1 + F_0\hat{e}_3 \quad (B7)$$

$$\hat{e}_3 = \hat{u}_3 - P\hat{e}_2 \quad (B8)$$

Proof of (3.11) ⇒ (3.12)

Suppose we apply $\tilde{u}_1 \in \mathcal{L}_{e1}$ and $\tilde{u}_2 \in \mathcal{L}_{e2}$ as inputs to 'S(P₁,F-F₀)
Let \tilde{e}_1 and \tilde{e}_2 be the resulting errors. We define

$$u_1 := \tilde{u}_1 \quad (B9)$$

$$e_1 := \tilde{e}_1 \quad (B10)$$

$$e_2 := (I-F_0(-P))^{-1}\tilde{e}_2 \quad (B11)$$

$$u_2 := \tilde{u}_2 + F_0(-P_1)\tilde{e}_2 - F_0(\tilde{u}_1 - P_1\tilde{e}_2) \quad (B12)$$

Step 1:

We will show that if u_1 and u_2 (as defined in (B9) and (B12)) are applied as inputs to 'S(P,F), the errors e_1 and e_2 (as defined in (B10) and (B11)) will satisfy the summing node eqns. of 'S(P,F).

Note that from (B5) and (B11) we have

$$Pe_2 = P_1 \tilde{e}_2 \quad (B13)$$

Now, using (B10), (B3) and (B11) in succession, we have:

$$e_1 = \tilde{e}_1 = \tilde{u}_1 - P_1 \tilde{e}_2 = \tilde{u}_1 - P_1(I-F_0(-P))e_2$$

and by (B5) and (B9), the last eqn. reduces to

$$e_1 = u_1 - Pe_2 \quad (B14)$$

whereas, using (B11), (B4) and (B10) in succession, we have

$$(I-F_0(-P))e_2 = \tilde{e}_2 = \tilde{u}_2 + (F-F_0)\tilde{e}_1 = \tilde{u}_2 + (F-F_0)e_1$$

hence, by (B12)

$$(I-F_0(-P))e_2 = u_2 - F_0(-P_1)\tilde{e}_2 + F_0(\tilde{u}_1 - P_1\tilde{e}_2) + (F-F_0)e_1$$

in which we use (B9) and (B13) to get

$$(I-F_0(-P))e_2 = u_2 - F_0(-Pe_2) + F_0(u_1 - Pe_2) + (F-F_0)e_1$$

Finally, (B14) gives

$$e_2 = u_2 + Fe_1 \quad (B15)$$

Thus, (B14) and (B15) tell us that the quadruple $(e_1, e_2, u_1, u_2) \in \mathcal{L}_{e_1} \times \mathcal{L}_{e_2} \times \mathcal{L}_{e_1} \times \mathcal{L}_{e_2}$ as defined in (B9)-(B12) satisfy the equations (B1) and (B2) describing 'S(P,F)

Step 2:

We will now show that the f.g. stability of 'S(P,F) implies that of 'S(P₁,F-F₀).

By the assumed f.g. stability of 'S(P,F) and Step 1, we know there are constants $K_1 < \infty$, $K_2 < \infty$, such that $\forall (\tilde{u}_1, \tilde{u}_2) \in \mathcal{L}_{e_1} \times \mathcal{L}_{e_2}$ and $\forall \tau \in T$

$$\|e_1\|_{\tau} \leq K_1 (\|u_1\|_{\tau} + \|u_2\|_{\tau}) \quad (B16)$$

$$\|e_2\|_{\tau} \leq K_2 (\|u_1\|_{\tau} + \|u_2\|_{\tau}) \quad (B17)$$

where (e_1, e_2, u_1, u_2) are defined in terms of $(\tilde{e}_1, \tilde{e}_2, \tilde{u}_1, \tilde{u}_2)$ by eqns. (B9)-(B12).

Also, from (B12) and the assumed inc. stability of F_0 we have,

$$\forall (\tilde{u}_1, \tilde{u}_2) \in \mathcal{L}_{e_1} \times \mathcal{L}_{e_2} \text{ and } \forall \tau \in T$$

$$\|u_2\|_{\tau} \leq \|\tilde{u}_2\| + \tilde{\gamma}(F_0) \|\tilde{u}_1\|_{\tau} . \quad (B18)$$

Finally by (B11), (B14), we obtain

$$\tilde{e}_2 = (I - F_0(-P))e_2 = e_2 - F_0(-P)e_2 + F_0(u_1 - Pe_2) - F_0e_1$$

and the assumed inc. stability of F_0 gives,

$$\forall (\tilde{u}_1, \tilde{u}_2) \in \mathcal{L}_{e_1} \times \mathcal{L}_{e_2} \text{ and } \forall \tau \in T$$

$$\|\tilde{e}_2\|_{\tau} \leq \|e_2\|_{\tau} + \tilde{\gamma}(F_0) \|u_1\|_{\tau} + \gamma(F_0) \|e_1\|_{\tau} \quad (B19)$$

We use (B16) and (B18) in eqn. (B10) to get

$$\|e_1\|_{\tau} = \|\tilde{e}_1\|_{\tau} \leq K_1 (\|u_1\|_{\tau} + \|\tilde{u}_2\|_{\tau} + (F_0)\|\tilde{u}_1\|_{\tau})$$

which, by (B9), gives

$\forall (\tilde{u}_1, \tilde{u}_2) \in \mathcal{L}_{e_1} \times \mathcal{L}_{e_2}$ and $\forall \tau \in T$

$$\|\tilde{e}_1\|_\tau \leq K_1[1 + \tilde{\gamma}(F_0)] \|\tilde{u}_1\| + K_1 \|\tilde{u}_2\|_\tau \quad (B20)$$

From (B16), (B17) and (B19) we have

$$\|\tilde{e}_2\|_\tau \leq [K_2 + \tilde{\gamma}(F_0) + K_1\gamma(F_0)] \|u_1\|_\tau + [K_2 + K_1\gamma(F_0)] \|u_2\|_\tau$$

which from (B9) and (B18) gives

$\forall (u_1, u_2) \in \mathcal{L}_{e_1} \times \mathcal{L}_{e_2}$ and $\forall \tau \in T$

$$\begin{aligned} \|\tilde{e}_2\|_\tau &\leq ([K_2 + K_1\gamma(F_0)][1 + \tilde{\gamma}(F_0)] + \tilde{\gamma}(F_0)) \|\tilde{u}_1\|_\tau \\ &\quad + [K_2 + K_1\gamma(F_0)] \|\tilde{u}_2\|_\tau \end{aligned} \quad (B21)$$

From (B20) and (B21) we see that $H_{\tilde{e}\tilde{u}} : (\tilde{u}_1, \tilde{u}_2) \mapsto (\tilde{e}_1, \tilde{e}_2)$ is f.g. stable.

Since $\tilde{y}_1 = \tilde{e}_2 - \tilde{u}_2$ and $\tilde{y}_2 = \tilde{u}_1 + \tilde{e}_1$, it follows that $H_{\tilde{y}\tilde{u}}$ is also f.g. stable. Thus 'S(P₁, F-F₀) is f.g. stable whenever 'S(P, F) is.

Proof of (3.12) ⇒ (3.11):

It follows the same lines as the above proof. We apply $u_1 \in \mathcal{L}_{e_1}$ and $u_2 \in \mathcal{L}_{e_2}$ to 'S(P, F). Let e_1 and e_2 be the resulting errors. We define

$$\tilde{u}_1 := u_1$$

$$\tilde{e}_1 := e_1$$

$$\tilde{e}_2 := (I - F_0(-P)) e_2$$

$$\tilde{u}_2 := u_2 - F_0(-P)e_2 + F_0(u_1 - Pe_2)$$

Then, assuming the f.g. stability of 'S(P₁, F-F₀) we establish, as above, the f.g. stability of 'S(P, F).

Proof of (3.12)⇒(3.13):

Suppose we apply $\hat{u}_1 \in \mathcal{L}_{e1}$, $\hat{u}_2 \in \mathcal{L}_{e2}$ and $\hat{u}_3 \in \mathcal{L}_{e1}$ as inputs to ${}^2S(P, F_0, F-F_0)$. Let \hat{e}_1 , \hat{e}_2 and \hat{e}_3 be the resulting errors.

We define

$$\check{e}_1 := \hat{e}_1 \quad (B22)$$

$$\check{e}_2 := (I-F_0(-P))\hat{e}_2 \quad (B23)$$

$$\check{u}_1 := \hat{u}_1 \quad (B24)$$

$$\check{u}_2 := \hat{u}_2 + F_0(\hat{u}_3 - P\hat{e}_2) - F_0(-P)\hat{e}_2 \quad (B]5)$$

Step 1:

We will show that if \check{u}_1 and \check{u}_2 (as defined in (B24) and (B25) are applied as inputs to ${}^1S(P_1, F-F_0)$ the errors \check{e}_1 and \check{e}_2 (as defined in (B22) and (B23)) will satisfy the summing node equations of ${}^1S(P_1, F-F_0)$.

From (B8), (B23) and (B5) we have

$$\hat{e}_3 = \hat{u}_3 - P\hat{e}_2 = \hat{u}_3 - P_1\check{e}_2 \quad (B26)$$

Applying (B22), (B6), (B24) and (B23) in succession

$$\check{e}_1 = \hat{e}_1 = \hat{u}_1 - P\hat{e}_2 = \check{u}_1 - P(I-F_0(-P))^{-1}\check{e}_2$$

So, by (B5)

$$\check{e}_1 = \check{u}_1 - P_1\check{e}_2 \quad (B27)$$

Now, (B7) gives

$$\begin{aligned} \hat{e}_2 &= \hat{u}_2 + F_0\hat{e}_3 + (F-F_0)\hat{e}_1 \\ &= \hat{u}_2 + F_0(\hat{u}_3 - P\hat{e}_2) + (F-F_0)\hat{e}_1 \quad (\text{by (B8)}) \\ &= \check{u}_2 + F_0(-P)\hat{e}_2 + (F-F_0)\hat{e}_1 \quad (\text{by (B25)}) \\ &= \check{u}_2 + F_0(-P)\hat{e}_2 + (F-F_0)\check{e}_1 \quad (\text{by (B22)}) \end{aligned}$$

So, by (B23)

$$\tilde{e}_2 = (I - F_0(-P))\hat{e}_2 = \tilde{u}_2 + (F - F_0)\tilde{e}_1 \quad (B28)$$

Thus, (B27) and (B28) tell us that the quadruple $(\tilde{e}_1, \tilde{e}_2, \tilde{u}_1, \tilde{u}_2) \in \mathcal{L}_{e1} \times \mathcal{L}_{e2} \times \mathcal{L}_{e1} \times \mathcal{L}_{e2}$, as defined in ((B22)-(B25)) satisfy the eqns. (B3) and (B4) of 'S(P₁, F-F₀).

Step 2:

We will now show that the f.g. stability of 'S(P₁, F-F₀) implies that of ²S(P, F₀, F-F₀).

By the assumed f.g. stability of 'S(P₁, F-F₀) and Step 1, we know there are constants M₁ < ∞ and M₂ < ∞ such that $\forall (\hat{u}_1, \hat{u}_2, \hat{u}_3) \in \mathcal{L}_{e1} \times \mathcal{L}_{e2} \times \mathcal{L}_{e1}$ and $\forall \tau \in T$

$$\|\tilde{e}_1\|_\tau \leq M_1[\|\tilde{u}_1\| + \|\tilde{u}_2\|_\tau] \quad (B29)$$

$$\|\tilde{e}_2\|_\tau \leq M_2[\|\tilde{u}_1\| + \|\tilde{u}_2\|_\tau] \quad (B30)$$

where $(\tilde{e}_1, \tilde{e}_2, \tilde{u}_1, \tilde{u}_2)$ are defined in terms of $(\hat{e}_1, \hat{e}_2, \hat{e}_3, \hat{u}_1, \hat{u}_2, \hat{u}_3)$ by eqns. (B22)-(B25).

From (B25) and the assumed inc. stability of F₀, we have:

$$\forall (\hat{u}_1, \hat{u}_2, \hat{u}_3) \in \mathcal{L}_{e1} \times \mathcal{L}_{e2} \times \mathcal{L}_{e1} \text{ and } \forall \tau \in T$$

$$\|\tilde{u}_2\|_\tau \leq \|\hat{u}_2\|_\tau + \tilde{\gamma}(F_0) \|\hat{u}_3\|_\tau \quad (B31)$$

From (B26) and the f.g. stability of P₁, we have

$$\forall (\hat{u}_1, \hat{u}_2, \hat{u}_3) \in \mathcal{L}_{e1} \times \mathcal{L}_{e2} \times \mathcal{L}_{e1} \text{ and } \forall \tau \in T$$

$$\|\hat{e}_3\|_\tau \leq \|\hat{u}_3\|_\tau + \gamma(P_1) \|\tilde{e}_2\|_\tau \quad (B32)$$

And since (B23) gives us

$$\begin{aligned}\hat{e}_2 &= (I - F_0(-P))^{-1} \tilde{e}_2 = [I + F_0(-P)(I - F_0(-P))^{-1}] \tilde{e}_2 \\ &= [I + F_0(-P_1)] \tilde{e}_2\end{aligned}$$

we have, by the f.g. stability of F_0 and P_1

$$\forall (\hat{u}_1, \hat{u}_2, \hat{u}_3) \in \mathcal{L}_{e1} \times \mathcal{L}_{e2} \times \mathcal{L}_{e1} \text{ and } \forall \tau \in T$$

$$\|\hat{e}_2\|_\tau \leq [1 + \gamma(F_0) \gamma(P_1)] \|\tilde{e}_2\|_\tau \quad (\text{B33})$$

Using (B29) and (B31) in (B22) gives

$$\|\hat{e}_1\|_\tau = \|\tilde{e}_1\|_\tau \leq M_1 [\|\tilde{u}_1\|_\tau + \|\hat{u}_2\|_\tau + \tilde{\gamma}(F_0) \|\hat{u}_3\|_\tau]$$

So, by (B24) we have

$$\forall (\hat{u}_1, \hat{u}_2, \hat{u}_3) \in \mathcal{L}_{e1} \times \mathcal{L}_{e2} \times \mathcal{L}_{e1} \text{ and } \forall \tau \in T$$

$$\|\hat{e}_1\|_\tau \leq M_1 [\|\hat{u}_1\|_\tau + \|\hat{u}_2\|_\tau + \tilde{\gamma}(F_0) \|\hat{u}_3\|_\tau] \quad (\text{B34})$$

From (B33) and (B30) we have

$$\|\hat{e}_2\|_\tau \leq [1 + \gamma(F_0) \gamma(P_1)] \cdot M_2 \cdot [\|\tilde{u}_1\|_\tau + \|\tilde{u}_2\|_\tau]$$

So, using (B24) and (B31) gives

$$\forall (\hat{u}_1, \hat{u}_2, \hat{u}_3) \in \mathcal{L}_{e1} \times \mathcal{L}_{e2} \times \mathcal{L}_{e1} \text{ and } \forall \tau \in T$$

$$\|\hat{e}_2\|_\tau \leq M_2 [1 + \gamma(F_0) \gamma(P_1)] [\|\hat{u}_1\|_\tau + \|\hat{u}_2\|_\tau + \gamma(F_0) \|\hat{u}_3\|_\tau] \quad (\text{B35})$$

Finally, (B32) and (B30) gives

$$\|\hat{e}_3\|_\tau \leq \|\hat{u}_3\|_\tau + M_2 \gamma(P_1) [\|\tilde{u}_1\|_\tau + \|\tilde{u}_2\|_\tau]$$

which, from (B24) and (B32) gives

$\forall (\hat{u}_1, \hat{u}_2, \hat{u}_3) \in \mathcal{L}_{e1} \times \mathcal{L}_{e2} \times \mathcal{L}_{e1}$ and $\forall \tau \in T$

$$\|\hat{e}_3\|_{\tau} \leq M_2 \gamma(P_1) [\|\hat{u}_1\|_{\tau} + \|\hat{u}_2\|_{\tau} + \tilde{\gamma}(F_0) \|\hat{u}_3\|_{\tau}] + \|\hat{u}_3\|_{\tau} \quad (B36)$$

From (B34)-(B36) we see that $H_{e\hat{u}} : (\hat{u}_1, \hat{u}_2, \hat{u}_3) \mapsto (\hat{e}_1, \hat{e}_2, \hat{e}_3)$ is f.g. stable. Since $\hat{y}_1 = \hat{e}_2 - \hat{u}_2 - F_0 \hat{e}_3$, $\hat{y}_2 = \hat{u}_3 - \hat{e}_3$, $\hat{y}_3 = F_0 \hat{e}_3$ and F_0 is f.g. stable, we see that $H_{y\hat{u}}$ is f.g. stable. Thus ${}^2S(P, F_0, F-F_0)$ is f.g. stable whenever ${}^1S(P_1, F-F_0)$ is

Proof of (3.13) \Rightarrow (3.12):

Specializing ${}^2S(P, F_0, F-F_0)$ by setting $\hat{u}_3 = 0$ gives ${}^1S(P_1, F-F_0)$.

Clearly f.g. stability of the former implies that of the latter.

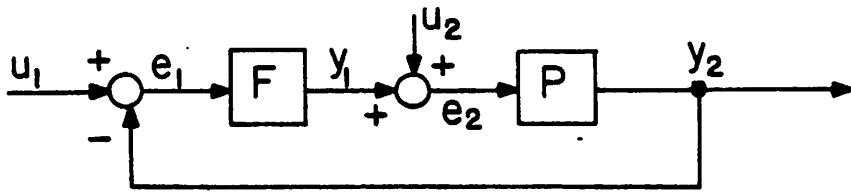

$^1S(P, F)$

figl. (a)

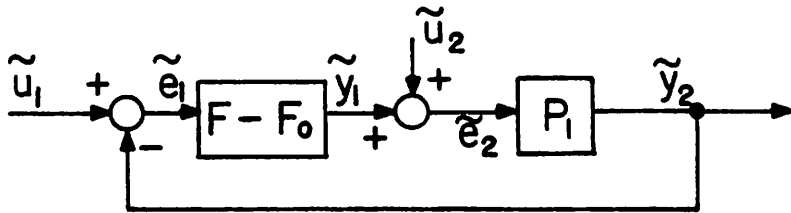

$^1S(P_1, F - F_0)$

(b)

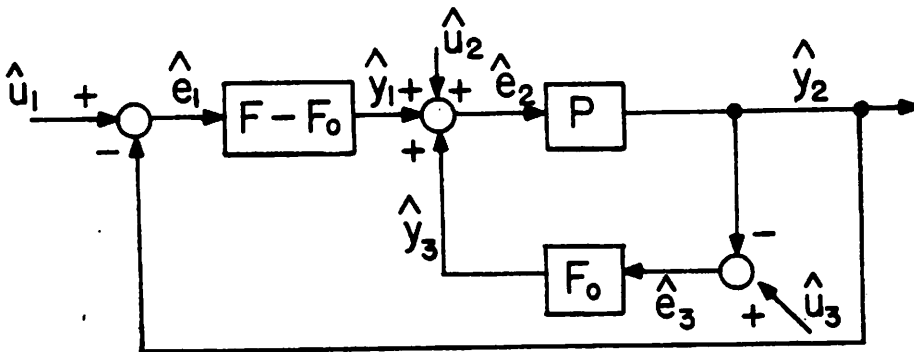

$^2S(P, F_0, F - F_0)$

(c)

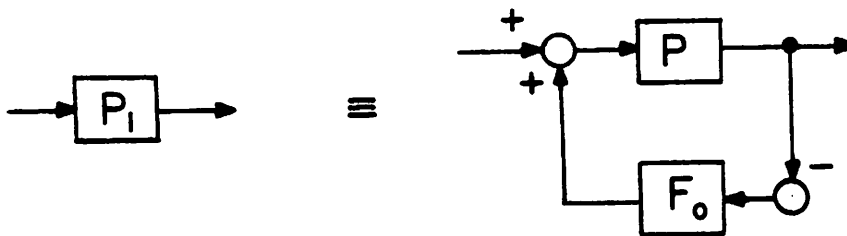

(d)