

Copyright © 1983, by the author(s).
All rights reserved.

Permission to make digital or hard copies of all or part of this work for personal or classroom use is granted without fee provided that copies are not made or distributed for profit or commercial advantage and that copies bear this notice and the full citation on the first page. To copy otherwise, to republish, to post on servers or to redistribute to lists, requires prior specific permission.

ARNOLD DIFFUSION IN THE SWING EQUATIONS OF
A POWER SYSTEM

by

F.M. Abdel Salam, J.E. Marsden and P.P. Varaiya

Memorandum No. UCB/ERL M83/13

9 March 1983

ELECTRONICS RESEARCH LABORATORY

College of Engineering
University of California, Berkeley
94720

ARNOLD DIFFUSION IN THE SWING EQUATIONS OF A POWER SYSTEM

Fathi M. Abdel Salam, Jerrold E. Marsden, and Pravin P. Varaiya

Department of Electrical Engineering and Computer Sciences

and

Department of Mathematics

University of California, Berkeley CA 94720

ABSTRACT

We present an application of the theory of Arnold diffusion to interconnected power systems. Using a Hamiltonian formulation, we show that Arnold diffusion arises on certain energy levels of the swing equations model. The occurrence of Arnold diffusion entails complex non-periodic dynamics and erratic transfer of energy between the subsystems. Conditions under which Arnold diffusion exists in the dynamics of the swing equations are found by using the vector-Melnikov method. These conditions become analytically explicit in the case when some of the subsystems undergo relatively small oscillations. Perturbation and parameter regions are found for which Arnold diffusion occurs. These regions allow for a class of interesting systems from the point of view of power systems engineering.

Research is partially supported by DOE contracts DE-AT03-82 ER 12097 and DE-ASOI-78ET29135 and the National Science Foundation grant ECS-811213. We thank Philip Holmes and Nancy Kopell for inspiration. We also thank Felix Wu, Eyad Abed, Aris Arapostathis, Rong Chen, Shankar Sastry and Nikos Tsolas for valuable discussions.

1. Introduction

We apply the results on Arnold diffusion of Holmes and Marsden [26] (see also [1, section 4]) to power systems. We note that the results in fact apply to all systems of the forced pendulum family such as interconnected power systems employing the swing equations model, coupled Josephson junction circuits with negligible dissipation, a Josephson junction driven by a direct current source (plus a small alternating current) coupled to two (respectively one) nonlinear oscillators, and coupled mechanical pendulums. The precise calculations are carried out here for a dynamical model of interconnected power systems.

In the dynamical behavior of a large interconnected power system, the question of transient stability is often considered. This concerns the system's behavior following a sudden fault (such as short circuit) or a large impact (such as lightning). The transient stability is precisely the Lyapunov stability in a state space formulation of a simplified differential equations model possessing multiple equilibria. Let the dynamics be given by $\dot{x} = f(x)$ and let x_0 be a stable equilibrium point which is presumably "closest" to the pre-fault equilibrium point (see [32,9]). The transient stability problem is to determine whether a given point in the state space belongs to the region of stability of this stable equilibrium point. Thus the transient stability problem leads to an investigation of the region of stability of a given stable equilibrium point [28,33,13,14,18]. Many studies of transient stability [28,33,13,14,18] have been conducted exploiting a first integral of the differential equation as a Lyapunov (energy) function.

Kopell and Washburn [29] were the first to show the presence of chaotic motion in the classical swing equations model of power systems for a 2 degree of freedom system (3 generators). Their work is based on the original Melnikov method for vector fields (see Holmes [24]) and the energy function was not exploited to locate the energy levels where chaos resides.

Here we show the presence of Arnold diffusion in the ($n \geq 3$)-degree of freedom Hamiltonian system (with constraints) of the classical model. In the case when ($n = 2$) only hor-

seshoes are present. This case is analogous to the one obtained by Kopell and Washburn except that we also specify the energy levels on which chaos resides, an advantage of exploiting the energy function.

The paper is organized in the following way. In section 2 we summarize the key result of Holmes and Marsden [26]. Section 3 contains some motivation and the derivation of the swing equations model. In section 4 we consider specific choices of parameter ranges to simplify the model before applying the results of section 2. In this section we also study the Hamiltonian formulation of the swing equations. They form a $2n$ degree of freedom system with two time-independent constraints. In section 5 we show that the conditions of section 2 can be satisfied for a large choice of parameters. These conditions can be simplified if all but one of the subsystems undergo small oscillations. This case is discussed in section 6. Conclusions and suggestions for future work are collected in section 7.

2. Arnold Diffusion in Hamiltonian Systems

In this section we summarize the results of Holmes and Marsden [26] for Hamiltonian systems with n -degrees of freedom ($n \geq 3$). These results extend the work of Arnold [11].

Problem Statement

Consider the unperturbed Hamiltonian system

$$H^0(q,p,\vec{x},\vec{y}) = F(q,p) + G(\vec{x},\vec{y}), \quad (2.1)$$

where F is a Hamiltonian which possesses a homoclinic orbit (\bar{q},\bar{p}) associated with a hyperbolic saddle point q_0,p_0 (one may similarly consider a heteroclinic orbit). Let \bar{h} be the energy constant of this orbit, i.e., $F(\bar{q},\bar{p}) = \bar{h}$. The parameters (q,p,\vec{x},\vec{y}) are assumed to be canonical coordinates on a $2(n+1)$ -dimensional symplectic manifold P ; q and p are real and $\vec{x} = (x_1, \dots, x_n)$, $\vec{y} = (y_1, \dots, y_n)$ are n -vectors. We assume that in a certain region of the state space a canonical transformation to *action-angle* coordinates $(\vartheta_1, \dots, \vartheta_n, I_1, \dots, I_n)$ can be found such that the system (2.1) takes the form

$$H^0(q,p,\vec{\vartheta},\vec{I}) = F(q,p) + \sum_{i=1}^n G_i(I_i) \quad (2.2)$$

where $G_j(0) = 0$ for all j

and

$$\Omega_j(I_j) = \frac{\partial G_j}{\partial I_j} > 0 \quad \text{for } I_j > 0 \quad (2.3)$$

Applying the reduction procedure (see Holmes and Marsden [25,26]), we solve $H^0 = h$ for I_n , thereby eliminating the action I_n . We also replace the time variable by the 2π -periodic angle ϑ_n . Then the equations

$$\begin{aligned} G_j(I_j) &= h_j \\ \vartheta_j &= \Omega_j(I_j)\vartheta_n + \vartheta_j(0), \quad j = 1, \dots, n-1 \\ q &= q_0, \quad p = p_0 \end{aligned} \quad (2.4)$$

describe an $(n-1)$ -parameter family of invariant $(n-1)$ -dimensional tori $\mathbb{T}(h_1, \dots, h_{n-1})$. For a fixed set of h_1, \dots, h_{n-1} , the torus $\mathbb{T}(h_1, \dots, h_{n-1})$ is connected to itself by the n -dimensional homoclinic manifold

$$\begin{aligned} G_j(I_j) &= h_j \\ \vartheta_j &= \Omega_j(I_j)\vartheta_n + \vartheta_j^0, \quad 1 \leq j \leq n-1 \\ q &= \bar{q}(\vartheta_n - \vartheta_n^0), \quad p = \bar{p}(\vartheta_n - \vartheta_n^0) \end{aligned} \quad (2.5)$$

This manifold consists of the coincident stable and unstable manifolds of the torus $\mathbb{T}(h_1, \dots, h_{n-1})$, i.e.,

$$W^s(\mathbb{T}(h_1, \dots, h_{n-1})) = W^u(\mathbb{T}(h_1, \dots, h_{n-1}))$$

The perturbed problem considered here has the following form

$$H^\mu(q,p,\vec{\vartheta},\vec{I}) = F(q,p) + \sum_{i=1}^n G_i(I_i) + \mu H^1(q,p,\vec{\vartheta},\vec{I}) \quad (2.6)$$

where H^1 is 2π -periodic in $\vartheta_1, \dots, \vartheta_n$ and $\mu > 0$. For sufficiently small μ , **KAM** theory asserts that (under non-resonance and non-degeneracy conditions given below) a positive measure of the $(n-1)$ -dimensional tori $\mathbb{T}(h_1, \dots, h_{n-1})$ persists (see Arnold [12, appendix 8]). We denote these tori by $\mathbb{T}_\mu(h_1, \dots, h_{n-1})$. Their corresponding stable and unstable manifolds

$W^s(T_\mu)$, respectively $W^u(T_\mu)$, are C^k close, $k \geq 1$, to the unperturbed homoclinic manifold

$$W^s(T(h_1, \dots, h_{n-1})) = W^u(T(h_1, \dots, h_{n-1}))$$

Let $h > \bar{h}$ be the total energy of the perturbed Hamiltonian H^μ of equation (2.6). Now consider the n -parameter family of orbits filling the unperturbed homoclinic manifold. Let

$$(\bar{q}, \bar{p}, \vartheta_1, \dots, \vartheta_n, I_1, \dots, I_n) = (\bar{q}(t), \bar{p}(t), \Omega_1(I_1)t + \vartheta_1^0, \dots, \Omega_n(I_n)t + \vartheta_n^0, I_1, \dots, I_n)$$

be the parameterization of these orbits and select one. Let $\left\{F, H^1\right\}$ denote the (q, p) Poisson bracket of $F(q, p)$ and $H^1(q, p, \vartheta_1, \dots, \vartheta_n, I_1, \dots, I_n)$ evaluated on this orbit. Similarly let

$$\left\{I_k, H^1\right\} = -\frac{\partial H^1}{\partial \vartheta_k}, \quad k = 1, \dots, n-1$$

be evaluated on the same orbit. Then define the Melnikov

vector $M(\vartheta^0) = (M_1, \dots, M_{n-1}, M_n)$ by

$$M_k(\vartheta_1^0, \dots, \vartheta_n^0, h, h_1, \dots, h_{n-1}) := \int_{-\infty}^{\infty} \left\{I_k, H^1\right\} dt, \quad k = 1, \dots, n-1 \quad (2.7)$$

and

$$M_n(\vartheta_1^0, \dots, \vartheta_n^0, h, h_1, \dots, h_{n-1}) := \int_{-\infty}^{\infty} \left\{F, H^1\right\} dt.$$

where the integrals above are required to be, in an appropriate sense, conditionally convergent. That is, they mean $\lim_{n \rightarrow \infty} \int_{-S_n}^{T_n}$ for suitable sequences $S_n, T_n \rightarrow \infty$.

Consider the following conditions:

(C1) F possesses a homoclinic orbit $(\bar{q}(t), \bar{p}(t))$ connecting a saddle point (q_0, p_0) to itself. Let

\bar{h} be the energy of this orbit.

(C2) $\Omega_j(I_j) = G_j'(I_j) > 0$ for $j = 1, \dots, n$.

(C3) The constants $G_j(I_j) = h_j$, $j = 1, \dots, n$ are chosen such that the unperturbed frequencies $\Omega_1(I_1), \dots, \Omega_n(I_n)$ satisfy the non-degeneracy conditions (i.e., $\Omega_j'(I_j) \neq 0$, $j = 1, \dots, n$) and the non-resonance condition, i.e., the equation

$\sum_{i=1}^n k_i \Omega_i(I_i) = 0$, where k_i are integers, implies $k_i = 0$ for all $1 \leq i \leq n$.

(C4) The multiple 2π -periodic Melnikov vector $\bar{M} : \mathbb{R}^n \rightarrow \mathbb{R}^n$ has at least one transversal zero, i.e., a point $(\vartheta_1^0, \dots, \vartheta_n^0)$ such that

$$\bar{M}(\vartheta_1^0, \dots, \vartheta_n^0) = 0$$

and

$$\det \left[DM(\vartheta_1^0, \dots, \vartheta_n^0) \right] \neq 0,$$

where DM is the $n \times n$ Jacobian matrix of the vector \bar{M} with respect to the initial phases $(\vartheta_1^0, \dots, \vartheta_n^0)$.

We can now state the main result.

Theorem 2.1 [Holmes & Marsden]

If conditions (C1)-(C4) hold for the perturbed system (2.6) then, for μ sufficiently small, the perturbed stable and unstable manifolds $W^s(T_\mu)$ and $W^u(T_\mu)$ of the perturbed torus T_μ intersect transversally. Moreover, a finite transition chain of such tori T_μ^1, \dots, T_μ^k can be chosen such that $W^u(T_\mu^j) \bar{\cap} W^s(T_\mu^{j+1})$ and $W^u(T_\mu^{j+1}) \bar{\cap} W^s(T_\mu^j)$, $1 \leq j \leq k-1$.

($\bar{\cap}$ denotes transversality of the intersection) The transition chain of tori are responsible for the occurrence of Arnold diffusion. Holmes and Marsden suggest that these transition tori can survive certain positive and negative damping, employing a technique which they had developed in [25].

An example which illustrates Theorem 2.1 is that of a simple pendulum linearly coupled to two nonlinear oscillators. Its perturbed Hamiltonian function can be written as follows (with the two oscillators in action-angle variables),

$$H^\mu = \frac{p^2}{2} - \cos q + G_1(I_1) + G_2(I_2) + \left(\frac{\mu}{2} \left[((2I_1)^{\frac{1}{2}} \sin \vartheta_1 - q)^2 + ((2I_2)^{\frac{1}{2}} \sin \vartheta_2 - q)^2 \right] \right)$$

One shows that conditions (C1)-(C4) are satisfied for this systems by direct computation.

3. The mathematical model

We introduce the simplest model of a power system. The equations resemble a system of differential equations describing a set of coupled pendulums with constant forcing. Recently [9,10,16,17,32] this model has been subjected to serious theoretical analysis to assist in understanding its dynamical behavior.

The model consists of three main components: generators, a transmission network and loads (fig 1). We assume that the transmission network has $(n+m)$ nodes numbered $1, \dots, n, n+1, \dots, n+m$ with 0 as a reference (datum). A generator is connected to each node 1 through n , while an impedance load is connected to every node (fig 1).

We perform a standard network reduction on the network, retaining as nodes only the internal nodes of the n generators. The swing equations which express the generator dynamics under the assumptions of constant rotor winding flux, constant mechanical torque, and the absence of voltage regulators are as follows (see [6,19,32] for details).

$$\frac{d}{dt} \delta_i = \omega_i - \omega_R$$

$$M_i \frac{d}{dt} \omega_i + D_i \omega_i = P_{mi} - P_{ei}, \quad i = 1, \dots, n$$

where

M_k : inertia constant

D_k : damping constant

P_{mk} : constant mechanical power (torque) input

P_{ek} : electrical power (torque) output demanded by the network

δ_k : the angle of the internal complex voltage or the torque angle of the k^{th} machine.

ω_k : the rotor angular velocity of the k^{th} machine

ω_R : the reference frequency of the power system (usually $\omega_R = 2\pi 60$ rad/sec)

The electrical power output is a function of the angle differences as follows,

$$P_{ei} := G_{ii}E_i^2 + \sum_{\substack{j=1 \\ j \neq i}}^n E_i E_j Y_{ij} \cos(\Theta_{ij} - \delta_i + \delta_j), \quad i = 1, \dots, n$$

where G_{ii} , Y_{ij} , Θ_{ij} and E_i , are all constants, defined as follows,

E_i : the magnitude of internal complex voltage (the magnitude of voltage behind the transient reactance).

Y_{ij} : the transfer admittance magnitude between internal nodes i and j .

Θ_{ij} : the transfer admittance phase between internal nodes i and j .

G_{ii} : the total admittance at the internal node of generator i .

Assume $\Theta_{ij} = \frac{\pi}{2}$ and assume also that the damping constants $D_i = 0$.

If we define P_i ($:= P_{mi} - G_{ii}E_i^2$) to be the exogenous specified mechanical input power and denote the constant quantity $E_i E_j Y_{ij} =: y_{ij}$, then we may write the swing equations for machine i as

$$\dot{\delta}_i = \omega_i - \omega_R \quad (3.1.i)$$

$$M_i \dot{\omega}_i = P_i - \sum_{\substack{j=1 \\ j \neq i}}^n y_{ij} \sin(\delta_i - \delta_j) \quad (3.2.i)$$

We note that the system of equations (3.1), (3.2) describe an n -degree of freedom Hamiltonian system with the energy function:

$$W = \sum_{i=1}^n \frac{1}{2} M_i (\omega_i - \omega_R)^2 - \sum_{i=1}^n P_i \delta_i - \sum_{i < j} y_{ij} \cos(\delta_i - \delta_j)$$

This energy function is Hamiltonian on the covering space R^{2n} , but only locally Hamiltonian on the "true" space $R^n \times T^n$ where the δ_j are considered modulo 2π .

The energy function W has been utilized as a Lyapunov function to determine an estimate of the region of attraction of a stable equilibrium point of the swing equations (see Willem's [41], El-Abiad and Nagapan [18], Fouad [19], Pai [32]).

Assume that the mechanical power produced is totally absorbed by the network, i.e.,

$$\sum_{i=1}^n P_i = 0. \quad (3.3)$$

Summing up equations (3.2.i) gives

$$\sum_{i=1}^n M_i \dot{\omega}_i = \sum_{i=1}^n P_i = 0.$$

Integrating with respect to time gives

$$\sum_{i=1}^n M_i \omega_i(t) = C_1 \quad (\text{constant}) \quad (3.4)$$

which when evaluated at the initial time $t=0$ equals

$$\sum_{i=1}^n M_i \omega_i(0) = C_1.$$

Using equations (3.1) and the constraint (3.4), one obtains

$$\sum_{i=1}^n M_i \dot{\delta}_i(t) = C_1 - \omega_R \sum_{i=1}^n M_i. \quad (3.5)$$

Let us define the total inertia of the system to be the sum of the individual inertias, i.e.,

$$M := \sum_{i=1}^n M_i.$$

Integrating the constraint equation (3.5) with respect to time, we obtain

$$\sum_{i=1}^n M_i \delta_i(t) = C_1 t - (\omega_R M) t + C_2. \quad (3.6)$$

Rewriting the constraints (3.4) and (3.6) and replacing the constants by their values one gets

$$\sum_{i=1}^n M_i \omega_i(t) = \sum_{i=1}^n M_i \omega_i(0) \quad (3.7)$$

$$\sum_{i=1}^n M_i \delta_i(t) = \sum_{i=1}^n M_i \delta_i(0) + t \left[\sum_{i=1}^n M_i \omega_i(0) - M \omega_R \right] \quad (3.8)$$

Equations (3.7) and (3.8) are time-dependent constraints. We make a coordinate change to transform these constraints to time-independent constraints, thus simplifying the system of equations. These constraint equations reduce the space of the dynamical motion by one degree of freedom or two dimensions, as is seen below.

Define the following transformation.

$$\omega_i \rightarrow \bar{\omega}_i = \omega_i - \frac{1}{M} \sum_{j=1}^n M_j \omega_j(0)$$

$$\delta_i \rightarrow \bar{\delta}_i = \delta_i + t \left[\omega_R - \frac{1}{M} \sum_{j=1}^n M_j \omega_j(0) \right] - \frac{1}{M} \sum_{j=1}^n M_j \delta_j(0)$$

where we have employed the so called center-of-angle reference frame without transforming to center-of-angle coordinates. Our transformation is analogous to the one utilized by Kopell and Washburn [29] except for the factor of $(1/M)$.

With this transformation and dropping the overbars we can summarize the autonomous swing equations with constraints as follows:

$$\dot{\delta}_i = \omega_i \tag{3.9.i}$$

$$M_i \dot{\omega}_i = P_i - \sum_{\substack{j=1 \\ j \neq i}}^n y_{ij} \sin(\delta_i - \delta_j), \quad 1 \leq i \leq n, \tag{3.10.i}$$

with the time-invariant constraints

$$\sum_{i=1}^n M_i \delta_i = 0 \tag{3.11}$$

$$\sum_{i=1}^n M_i \omega_i = 0 \tag{3.12}$$

and the energy (Hamiltonian) function

$$W = \sum_{i=1}^n \frac{1}{2} M_i \omega_i^2 - \sum_{i=1}^n P_i \delta_i - \sum_{i < j} \sum y_{ij} \cos(\delta_i - \delta_j) \tag{3.13}$$

From the constraint equations (3.11) and (3.12) it is observed that the system can be reduced by one degree of freedom. This procedure of eliminating a degree of freedom by making use of a conservation law is a special case of the procedure of reduction; see Abraham and Marsden [4, ch.4].

4. Perturbation and Scaling Parameters

We begin by choosing "transfer" parameters for the swing equations model.

4.1. Transfer susceptance parameters

Choose the coupling parameters y_{ij} , $i, j = 1, 2, \dots, n-1$ to be very small (i.e., weak coupling) of order ε , $\varepsilon > 0$, (how small ε must be, is determined later). Let (recall $y_{ij} = y_{ji}$)

$$y_{ij} = \varepsilon B_{ij} \quad 1 \leq i, j \leq n-1 \quad i \neq j$$

and

$$y_{in} = B_{in} \quad 1 \leq i \leq n-1.$$

Then our system of equations becomes

$$\dot{\delta}_k = \omega_k \quad 1 \leq k \leq n \quad (4.1.k)$$

$$M_i \dot{\omega}_i = P_i - \varepsilon \sum_{\substack{j=1 \\ j \neq i}}^{n-1} B_{ij} \sin(\delta_i - \delta_j) - B_{in} \sin(\delta_i - \delta_n) \quad 1 \leq i \leq n-1 \quad (4.2.i)$$

$$M_n \dot{\omega}_n = P_n - \sum_{j=1}^{n-1} B_{nj} \sin(\delta_n - \delta_j) \quad (4.2.n)$$

with time-invariant constraints

$$\sum_{i=1}^n M_i \delta_i = 0, \quad \text{or} \quad \delta_n = - \sum_{j=1}^{n-1} \frac{M_j}{M_n} \delta_j \quad (4.3)$$

$$\sum_{i=1}^n M_i \omega_i = 0, \quad \text{or} \quad \omega_n = - \sum_{j=1}^{n-1} \frac{M_j}{M_n} \omega_j \quad (4.4)$$

and the Hamiltonian

$$\begin{aligned} W^e(\delta_1, \dots, \delta_n, \omega_1, \dots, \omega_n) = & \sum_{j=1}^{n-1} \frac{1}{2} M_j \omega_j^2 + \frac{1}{2} M_n \omega_n^2 - \sum_{j=1}^{n-1} P_j \delta_j - P_n \delta_n \\ & - \varepsilon \sum_{\substack{i < j \\ i, j=1}}^{n-1} B_{ij} \cos(\delta_i - \delta_j) - \sum_{j=1}^{n-1} B_{jn} \cos(\delta_j - \delta_n) \end{aligned} \quad (4.5)$$

4.2. The case of uncoupled machines

Consider the case $\varepsilon = 0$. This corresponds to machines $1, \dots, n-1$ are connected to machine n but not to each other. From (4.3), (4.4) and (4.5),

$$W^0(\delta_1, \dots, \delta_{n-1}, \omega_1, \dots, \omega_{n-1}) = \sum_{j=1}^{n-1} \frac{1}{2} M_j \omega_j^2 + \frac{1}{2} M_n \left[- \sum_{k=1}^{n-1} \frac{M_k}{M_n} \omega_k \right]^2$$

$$-\sum_{j=1}^{n-1} P_j \delta_j + P_n \left(\sum_{k=1}^{n-1} \frac{M_k}{M_n} \delta_k \right) - \sum_{j=1}^{n-1} B_{jn} \cos \left(\delta_j + \sum_{k=1}^{n-1} \frac{M_k}{M_n} \delta_k \right) \quad (4.6)$$

Our next main concern is to evaluate the effect of the two states δ_n and ω_n on the rest of the system. These states are functions of the rest of the states subscripted $1, \dots, n-1$ via equations (4.3) and (4.4) and thus they produce the coupling of equation (4.6).

ω_n and δ_n shall be restricted to be periodic with small amplitude. This implies that the coupling Hamiltonian of equation (4.6) shall be of the same small order and hence one obtains the Hamiltonian formulation of Arnold diffusion as in section 2 (see also [26] and [1]). In the power systems context this amounts to considering the effect of the largest (infinite) machine on the system.

4.3. Determination of the Critical Set

We now locate the critical points of the energy function W^0 . They must satisfy the following equations.

$$\begin{aligned} \frac{\partial W^0}{\partial (M_j \omega_j)} &= \frac{1}{M_j} \left[M_j \omega_j + M_n \omega_n \frac{d\omega_n}{d\omega_j} \right] = 0 \\ \frac{\partial W^0}{\partial \delta_j} &= -P_j + B_{jn} \sin(\delta_j - \delta_n) + \left(\frac{d\delta_n}{d\delta_j} \right) \left[-P_n - \sum_{l=1}^{n-1} B_{ln} \sin(\delta_l - \delta_n) \right] = 0. \end{aligned}$$

Recall from section 2 that $P_n = -\sum_{j=1}^{n-1} P_j$, so we may write the critical set equations as follows,

$$\frac{\partial W^0}{\partial (M_j \omega_j)} = \omega_j + \sum_{k=0}^{n-1} \frac{M_k}{M_n} \omega_k = 0 \quad (4.7.j)$$

$$\frac{\partial W^0}{\partial \delta_j} = -P_j + B_{jn} \sin(\delta_j + \sum_{k=0}^{n-1} \frac{M_k}{M_n} \delta_k) - \frac{M_j}{M_n} \left[\sum_{i=1}^{n-1} (P_i - B_{in} \sin(\delta_i - \delta_n)) \right] = 0 \quad (4.8.j)$$

or in a matrix form

$$\begin{bmatrix} \frac{\partial W^0}{\partial(M_j \omega_j)} \\ \frac{\partial W^0}{\partial \delta_j} \end{bmatrix} = \begin{bmatrix} A & 0 \\ 0 & B \end{bmatrix} \begin{bmatrix} \omega_j \\ -P_j + B_{jn} \sin(\delta_j + \sum_{k=1}^{n-1} \frac{M_k}{M_n} \delta_k) \end{bmatrix} = 0$$

with the elements of A given by

$$a_{jj} = 1 + \frac{M_j}{M_n} \quad \text{and} \quad a_{jk} = \frac{M_k}{M_n} \quad \text{for all } j, k \quad \text{and } j \neq k.$$

Similarly, the elements of B are

$$b_{jj} = 1 + \frac{M_j}{M_n} \quad \text{and} \quad b_{jk} = \frac{M_j}{M_n} \quad \text{for all } j, k \quad \text{and } j \neq k.$$

Therefore the $2(n-1) \times 2(n-1)$ matrix

$$\begin{bmatrix} A & 0 \\ 0 & B \end{bmatrix}$$

is nonsingular with determinant > 1 . Thus equations (4.7) and (4.8) are equivalent to the following simpler conditions:

$$\omega_i = 0 \tag{4.9.i}$$

$$P_i - B_{in} \sin(\delta_i + \sum_{k=1}^{n-1} \frac{M_k}{M_n} \delta_k) = 0, \quad 1 \leq i \leq n-1. \tag{4.10.i}$$

Let $\Delta_i := \delta_i + \sum_{k=1}^{n-1} \frac{M_k}{M_n} \delta_k$, and define

$$\Delta_i^s := \delta_i^s + \sum_{k=1}^{n-1} \frac{M_k}{M_n} \delta_k^s \tag{4.11.i}$$

to be the mod- (2π) constant "angle" such that (4.10.i) is satisfied for all $i = 1, \dots, n-1$. Assume that the point $((\Delta_i^s, 0), i = 1, \dots, n-1)$ is a local minimum of the energy function W^0 (or a stable point of the differential equation, see [8,16,37] for a detailed treatment of the critical set). One can verify that every point of the critical set is non-degenerate (the Hessian matrix of W^0 is nonsingular).

We remark that the $\Delta_i^s, i = 1, \dots, n-1$, uniquely determine the $\delta_k^s, k = 1, \dots, n-1$, i.e., the matrix defining the linear map $(\delta_1^s, \dots, \delta_{n-1}^s) \rightarrow (\Delta_1^s, \dots, \Delta_{n-1}^s)$ of (4.11) is invertible.

Let us now define as new state variables (α, ω) where

$$\alpha = (\sigma_1, \dots, \sigma_{n-1}), \quad \text{with} \quad \sigma_k = \delta_k - \delta_k^g \quad 1 \leq k \leq n-1, \text{ and}$$

$\omega = (\omega_1, \dots, \omega_{n-1})$ is the same as before. Then we rewrite the Hamiltonian as follows

$$\begin{aligned} H(\alpha, \omega) = & \sum_{i=1}^{n-1} \frac{1}{2} M_i \omega_i^2 + \frac{1}{2} M_n \left[- \sum_{k=1}^{n-1} \frac{M_k}{M_n} \omega_k \right]^2 \\ & - \sum_{i=1}^{n-1} P_i \sigma_i + P_n \left[\sum_{k=1}^{n-1} \frac{M_k}{M_n} \sigma_k \right] \\ & - \sum_{i=1}^{n-1} B_{in} \left[\cos(\sigma_i + \sum_{k=1}^{n-1} \frac{M_k}{M_n} \sigma_k + \Delta_i^g) - \cos(\Delta_i^g) \right] \end{aligned}$$

with $H(0,0) = 0$.

4.4. The Choice of Constants (Parameters)

Suppose $M_{n-1} \ll M_1, \dots$, and $M_{n-2} \ll M_n$. Let us express this condition by introducing a nonzero small parameter α such that

$$M_n := \frac{M_n^\infty}{\alpha^2}, \quad M_{n-1} := \bar{M}_{n-1}, \quad \text{and} \quad M_i := \frac{\bar{M}_i}{\alpha} \quad 1 \leq i \leq n-2$$

where the overbarred quantities are of the same order ($O(1)$) and M_n^∞ is large. Denote

$$\begin{aligned} \mu_i &= \frac{\bar{M}_i}{M_n^\infty} \quad 1 \leq i \leq n-2 \\ \mu_{n-1} &= \alpha \bar{\mu}_{n-1} = \alpha \frac{\bar{M}_{n-1}}{M_n^\infty} \end{aligned}$$

Note that for an infinite machine (i.e., M_n or $M_n^\infty \rightarrow \infty$), we have $\mu_i \rightarrow 0$, $1 \leq i \leq n-1$. We further require that each "large" machine is connected to the n -th machine via a "strong" line (see fig 2), i.e., we let

$$B_{in} = \frac{\bar{B}_i}{\alpha}, \quad 1 \leq i \leq n-2 \quad \text{and} \quad B_{n-1,n} = \bar{B}_{n-1}$$

Correspondingly let

$$P_n = \frac{\bar{P}_n}{\alpha}, \quad P_i = \frac{\bar{P}_i}{\alpha}, \quad 1 \leq i \leq n-2 \quad \text{and} \quad P_{n-1} = \bar{P}_{n-1}.$$

Let $\mu = (\mu_1, \dots, \mu_{n-2}, \bar{\mu}_{n-1})$, and rewrite the Hamiltonian function as

$$\begin{aligned}
H^{(\mu, \alpha)} &= \sum_{i=1}^{n-2} \frac{1}{2} \frac{\bar{M}_i}{\alpha} \omega_i^2 + \frac{1}{2} \bar{M}_{n-1} \omega_{n-1}^2 + \frac{1}{2} \frac{M_n^\infty}{\alpha^2} \left[\alpha \sum_{k=1}^{n-1} \mu_k \omega_k \right]^2 \\
&\quad - \sum_{i=1}^{n-2} \frac{\bar{P}_i}{\alpha} \sigma_i - \bar{P}_{n-1} \sigma_{n-1} + \frac{\bar{P}_n}{\alpha} \left[\sum_{k=1}^{n-1} \alpha \mu_k \sigma_k \right] \\
&\quad - \sum_{i=1}^{n-2} \frac{\bar{B}_i}{\alpha} \left[\cos(\sigma_i + \alpha \sum_{k=1}^{n-1} \mu_k \sigma_k + \Delta_i^s) - \cos(\Delta_i^s) \right] \\
&\quad - \bar{B}_{n-1} \left[\cos(\sigma_{n-1} + \alpha \sum_{k=1}^{n-1} \mu_k \sigma_k + \Delta_{n-1}^s) - \cos(\Delta_{n-1}^s) \right]
\end{aligned} \tag{4.12}$$

One may observe from (4.12) that the coupling between subsystems 1, ..., n-1 is due to the states δ_n and ω_n of the n-th machine. That is, if $M_n^\infty = \infty$ then the parameters $\mu_k = 0$, $k = 1, \dots, n-1$ and one obtains the decoupled ('unperturbed') Hamiltonian. For notational simplicity let $\mu_1 = \dots = \mu_{n-2} = \bar{\mu}_{n-1} = \mu$.

The unperturbed Hamiltonian ($\mu = 0$) is

$$\begin{aligned}
H^{(0, \alpha)} &= \sum_{i=1}^{n-2} \frac{1}{2} \frac{\bar{M}_i}{\alpha} \omega_i^2 - \sum_{i=1}^{n-2} \frac{\bar{P}_i}{\alpha} \sigma_i - \sum_{i=1}^{n-2} \frac{\bar{B}_i}{\alpha} \left[\cos(\sigma_i + \Delta_i^s) - \cos(\Delta_i^s) \right] + \\
&\quad \left\{ \frac{1}{2} \bar{M}_{n-1} \omega_{n-1}^2 - \bar{P}_{n-1} \sigma_{n-1} - \bar{B}_{n-1} \left[\cos(\sigma_{n-1} + \Delta_{n-1}^s) - \cos(\Delta_{n-1}^s) \right] \right\}
\end{aligned} \tag{4.13}$$

We note that the perturbation affects the critical set: the unperturbed system has the point $(\Delta_1^s, \dots, \Delta_{n-1}^s, \Omega)$ as a critical point. But after perturbation this critical point is transformed to the point $(\delta_1^s, \dots, \delta_{n-1}^s, \Omega)$ via equation (4.11). Thus it is necessary to use the Melnikov version developed by Holmes and Marsden [26].

The perturbation parameter is μ and the purpose of the parameter α is explained as follows. The unperturbed (i.e., $\mu = 0$) Hamiltonian system describes a system of pendulums with constant forcing. The phase portrait of each of its subsystems is thoroughly discussed in Andronov and Chaikin [7, p.293]. Under the assumptions that $\bar{P}_j < \bar{B}_j$, $1 \leq j \leq n-1$, one obtains the phase portrait for each subsystem j as in fig (3).

The parameter α is selected to boost the energy values of the level curves of subsystem i , $1 \leq i \leq n-2$, compared to the energy values of the level curves of the subsystem $n-1$. More

precisely let the energy constant of the separatrix (or homoclinic orbit) of subsystem $n-1$ be \bar{h} . Then one chooses α small enough such that the total (system's) unperturbed Hamiltonian, with an energy constant $h > \bar{h}$ and h close to \bar{h} , possesses solution curves which are cross products of one homoclinic orbit (that of subsystem $n-1$) and $(n-2)$ closed orbits (those of subsystem i , $1 \leq i \leq n-2$).

As a consequence of this choice of parameters, the Hamiltonian system will satisfy the first three conditions of section 2 (i.e., (C1)-(C3)). Also note that the combined subsystems i , $1 \leq i \leq n-2$ admit, implicitly, action-angle coordinates (see Arnold [12, pp. 285]).

We now scale the perturbed Hamiltonian $H^{(\mu, \alpha)}$, (equation 4.12), by multiplying through by $(\frac{\alpha}{\bar{M}_j})$, where $\bar{M}_j : 1 \leq j \leq n-1$ are of the same order $(O(1))$ (for clarity, assume all \bar{M}_j are the same). We expand in powers of the small perturbation parameter μ to obtain the following (expanded) Hamiltonian.

$$\begin{aligned}
H^\mu = & \sum_{i=1}^{n-2} \frac{1}{2} \omega_i^2 - \rho_i \sigma_i - \beta_i \left[\cos(\sigma_i + \Delta_i^s) - \cos(\Delta_i^s) \right] \\
& + \alpha \left[\frac{1}{2} \omega_{n-1}^2 - \rho_{n-1} \sigma_{n-1} - \beta_{n-1} \left[\cos(\sigma_{n-1} + \Delta_{n-1}^s) - \cos(\Delta_{n-1}^s) \right] \right] \\
& + \alpha \mu \frac{1}{2} \left[\sum_{i=1}^{n-2} \omega_i + \alpha \omega_{n-1} \right]^2 + \alpha \mu \left[\sum_{i=1}^{n-2} \rho_n \sigma_i + \alpha \rho_n \sigma_{n-1} \right] \\
& + \alpha \mu \sum_{i=1}^{n-2} \beta_i \sin(\sigma_i + \Delta_i^s) \left[\sum_{k=1}^{n-2} \sigma_k + \alpha \sigma_{n-1} \right] + O(\alpha^2 \mu^2) \\
& + \alpha^2 \mu \beta_{n-1} \sin(\sigma_{n-1} + \Delta_{n-1}^s) \left[\sum_{k=1}^{n-2} \sigma_k + \alpha \sigma_{n-1} \right] + O(\alpha^3 \mu^2)
\end{aligned} \tag{4.14}$$

where $\rho_k = \bar{P}_k / \bar{M}_k$, $\beta_k = \bar{B}_k / \bar{M}_k$ and so on.

At this point one may identify the subsystems as follows:

(A) The subsystem $(n-1)$,

$$\alpha \bar{F}(\sigma_{n-1}, \omega_{n-1}) = \alpha \left(\frac{1}{2} \omega_{n-1}^2 - \rho_{n-1} \sigma_{n-1} - \beta_{n-1} [\cos(\sigma_{n-1} + \Delta_{n-1}^s) - \cos(\Delta_{n-1}^s)] \right)$$

(the Hamiltonian of a pendulum with constant forcing), which possesses the homoclinic orbit denoted $(\bar{\sigma}_{n-1}, \bar{\omega}_{n-1})$ and shown in fig(4). Let $\bar{F}(\bar{\sigma}_{n-1}, \bar{\omega}_{n-1}) = \bar{h}$.

(B) For each i , $i = 1, \dots, n-2$, the subsystem(i)

$$G_i(\sigma_i, \omega_i) = \frac{1}{2} \omega_i^2 - \rho_i \sigma_i - \beta_i \left[\cos(\sigma_i + \Delta_i^s) - \cos(\Delta_i^s) \right]$$

which is a nonlinear oscillator with amplitude-dependent frequencies (this is a property of the closed orbits of a pendulum phase portrait (see fig 5)). Denote a solution curve of the oscillator i , which is a projection of a homoclinic orbit of the total unperturbed system on the subspace i , by $(\bar{\sigma}_i, \bar{\omega}_i)$.

(AB) Finally we identify the terms of order μ as a perturbation energy function, H^1 ,

$$\begin{aligned} H^1 = & \frac{1}{2} \alpha \left[\sum_{i=1}^{n-2} \omega_i + \alpha \omega_{n-1} \right]^2 + \alpha \left[\sum_{i=1}^{n-2} \rho_n \sigma_i + \alpha \rho_n \sigma_{n-1} \right] \\ & + \alpha \sum_{i=1}^{n-2} \beta_i \sin(\sigma_i + \Delta_i^s) \left[\sum_{k=1}^{n-2} \sigma_k + \alpha \sigma_{n-1} \right] + \alpha^2 \beta_{n-1} \sin(\sigma_{n-1} + \Delta_{n-1}^s) \left[\sum_{k=1}^{n-2} \sigma_k + \alpha \sigma_{n-1} \right] \end{aligned}$$

5. The Existence of Arnold Diffusion

We now investigate whether the conditions of section 2 can be verified. First one notes that the solutions of each subsystem i , $1 \leq i \leq n-2$, are all closed orbits. Thus the solutions of the combined $(n-2)$ -subsystems lie on $(n-2)$ dimensional tori and a transformation to action-angle variables is possible. In fact for each subsystem i the action is

$$I_i(\bar{h}_i) = \frac{1}{\pi} \int_{\sigma_{i,\min}}^{\sigma_{i,\max}} \left[2(\bar{h}_i + \rho_i \sigma_i + \beta_i \cos(\sigma_i + \Delta_i^s)) \right]^{\frac{1}{2}} d\sigma_i \quad (5.1.i)$$

where

$$\bar{h}_i := h_i - \cos(\Delta_i^s) \quad , \quad \bar{h}_i < -\rho_i(\pi - \Delta_i^s) + \beta_i \cos(\Delta_i^s)$$

h_i is the energy constant such that $G_i(\sigma_i, \omega_i) = h_i$

$\sigma_{i,\max}$ ($\sigma_{i,\min}$) is the maximum (minimum) value of σ_i at which the energy level curve,

$G_i(\sigma_i, \omega_i) = h_i$ crosses the σ_i -axis.

If $\rho_i = 0$, the integral (5.1.i) may be transformed into an elliptic integral which can be looked up in Integral Tables.

Secondly, the frequencies Ω_i of the closed orbits of each subsystem i , $1 \leq i \leq n-2$, are amplitude dependent. Therefore one may select energy constants $G_i(\sigma_i, \omega_i) = h_i$, $1 \leq i \leq n-2$, such that these frequencies are rationally independent. Thus the first three conditions of section 2 ((C1), (C2) and (C3)) are clearly satisfied. Now we seek to satisfy condition (C4), so we compute the Melnikov integrals.

Using the perturbed Hamiltonian H^μ , eqn. (4.14), and evaluating the integrals along a homoclinic orbit $(\bar{\sigma}_1, \dots, \bar{\sigma}_{n-1}, \bar{\omega}_1, \dots, \bar{\omega}_{n-1})$, one obtains

$$\begin{aligned} \widetilde{M}_i := \int_{-\infty}^{\infty} \left\{ G_i, H^1 \right\} dt &= \int_{-\infty}^{\infty} -\bar{\omega}_i \left[\alpha \left(-\beta_i \cos(\bar{\sigma}_i + \Delta_i^s) \left[\sum_{k=1}^{n-2} \bar{\sigma}_k + \alpha \bar{\sigma}_{n-1} \right] \right. \right. \\ &+ \alpha \left[\sum_{j=1}^{n-2} \rho_j - \beta_j \sin(\bar{\sigma}_j + \Delta_j^s) \right] \\ &+ \alpha^2 \left[\rho_{n-1} - \beta_{n-1} \sin(\bar{\sigma}_{n-1} + \Delta_{n-1}^s) \right] \left. \right) \\ &+ \alpha \left[\sum_{k=1}^{n-2} \bar{\omega}_k + \alpha \bar{\omega}_{n-1} \right] \left(\rho_i - \beta_i \sin(\bar{\sigma}_i + \Delta_i^s) \right) dt \end{aligned} \tag{5.2.i}$$

We note that only a product of the oscillators variables (subscripted i , $1 \leq i \leq n-2$) with the homoclinic orbit variables (subscripted $(n-1)$) would produce nonvanishing terms.

The Melnikov integral measures the separation between the stable and unstable manifolds by measuring the energy differences along two curves which are, respectively, asymptotic to the invariant torus as $t \rightarrow \infty$ and $t \rightarrow -\infty$. Because these curves need not be close on the torus, the limits of integration must be chosen carefully. Such terms arise from products of oscillator variables in (5.2.i). These terms are zero when the appropriate limits are chosen, and so may be omitted from (5.2.i) - see appendix A (A similar phenomena occurs in the pendulum oscillator example of Holmes and Marsden [26] although they did not discuss it]). Hence the integral of (5.2.i) above reduces to

$$\begin{aligned} \widetilde{M}_1 = \int_{-\infty}^{\infty} & \left\{ -\alpha^2 \left[\frac{d}{dt} \left[\rho_1 - \beta_1 \sin(\bar{\sigma}_1 + \Delta_1^s) \right] \right] \bar{\sigma}_{n-1} + \alpha^2 \left[\rho_1 - \beta_1 \sin(\bar{\sigma}_1 + \Delta_1^s) \right] \bar{\omega}_{n-1} \right. \\ & \left. - \alpha^2 \left[\rho_{n-1} - \beta_{n-1} \sin(\bar{\sigma}_{n-1} + \Delta_{n-1}^s) \right] \bar{\omega}_1 \right\} dt \end{aligned}$$

One may divide by α^2 to obtain the Melnikov integral independent of the (scaling) parameter α . Letting $\widehat{M}_1 = \frac{\widetilde{M}_1}{\alpha^2}$,

$$\begin{aligned} \widehat{M}_1 = \int_{-\infty}^{\infty} & \left\{ - \left[\frac{d}{dt} \left[\rho_1 - \beta_1 \sin(\bar{\sigma}_1(\Omega_1(t - t_i)) + \Delta_1^s) \right] \right] \bar{\sigma}_{n-1}(t) \right. \\ & + \left[\rho_1 - \beta_1 \sin(\bar{\sigma}_1(\Omega_1(t - t_i)) + \Delta_1^s) \right] \bar{\omega}_{n-1}(t) \\ & \left. - \left[\rho_{n-1} - \beta_{n-1} \sin(\bar{\sigma}_{n-1}(t) + \Delta_{n-1}^s) \right] \bar{\omega}_1(\Omega_1(t - t_i)) \right\} dt \end{aligned} \quad (5.3.i)$$

where the variables $\bar{\sigma}_i, \bar{\omega}_i$ are periodic in t , and with (amplitude dependent) frequency Ω_i .

Note that $\bar{\omega}_i(\Omega_i t) = \frac{d}{dt} \bar{\sigma}_i(\Omega_i t)$. Similarly, along the same homoclinic orbit

$(\bar{\sigma}_1, \dots, \bar{\sigma}_{n-1}, \bar{\omega}_1, \dots, \bar{\omega}_{n-1})$ one computes

$$\begin{aligned} \widetilde{M}_{n-1} & := \int_{-\infty}^{\infty} \{ F \cdot H^1 \} dt \\ & = \int_{-\infty}^{\infty} -\alpha \bar{\omega}_{n-1} \left\{ \alpha^2 (-\beta_{n-1} \cos(\bar{\sigma}_{n-1} + \Delta_{n-1}^s)) \left[\sum_{k=1}^{n-2} \bar{\sigma}_k + \alpha \bar{\sigma}_{n-1} \right] \right. \\ & \quad \left. + \alpha^2 \left[\sum_{j=1}^{n-2} \rho_j - \beta_j \sin(\bar{\sigma}_j + \Delta_j^s) \right] + \alpha^3 \left[\rho_{n-1} - \beta_{n-1} \sin(\bar{\sigma}_{n-1} + \Delta_{n-1}^s) \right] \right\} \\ & \quad + \alpha^2 \left[\sum_{k=1}^{n-2} \bar{\omega}_k + \alpha \bar{\omega}_{n-1} \right] \alpha \left[\rho_{n-1} - \beta_{n-1} \sin(\bar{\sigma}_{n-1} + \Delta_{n-1}^s) \right] dt. \end{aligned} \quad (5.4)$$

As before, products of oscillator variables can be omitted and so only a product of variables of subscripts $\{i = 1, \dots, n-2\}$ and $\{n-1\}$ contribute to the evaluation of the integrals. Hence the

Melnikov integral reduces to

$$\begin{aligned} \widetilde{M}_{n-1} &= \int_{-\infty}^{\infty} \left\{ -\alpha^3 \left[\frac{d}{dt} \left(\rho_{n-1} - \beta_{n-1} \sin(\bar{\sigma}_{n-1} + \Delta_{n-1}^s) \right) \right] \sum_{k=1}^{n-2} \bar{\sigma}_k \right. \\ &\quad \left. - \alpha^3 \left[\sum_{j=1}^{n-2} \left(\rho_j - \beta_j \sin(\bar{\sigma}_j + \Delta_j^s) \right) \bar{\omega}_{n-1} \right] \right. \\ &\quad \left. + \alpha^3 \left[\sum_{k=1}^{n-2} \left(\rho_{n-1} - \beta_{n-1} \sin(\bar{\sigma}_{n-1} + \Delta_{n-1}^s) \right) \bar{\omega}_k \right] \right\} dt \end{aligned}$$

which shows that the Melnikov function can be made independent of α , (α does not affect the transversal zeros), we therefore scale the Melnikov integral as follows. Let $\widehat{M}_{n-1} = \frac{\widetilde{M}_{n-1}}{\alpha^3}$, so

$$\begin{aligned} \widehat{M}_{n-1} &= \sum_{k=1}^{n-2} \int_{-\infty}^{\infty} \left\{ -\frac{d}{dt} \left[\rho_{n-1} - \beta_{n-1} \sin(\bar{\sigma}_{n-1} + \Delta_{n-1}^s) \right] \bar{\sigma}_k(\Omega_k(t-t_k)) \right. \\ &\quad \left. + \left[\rho_{n-1} - \beta_{n-1} \sin(\bar{\sigma}_{n-1} + \Delta_{n-1}^s) \right] \bar{\omega}_k(\Omega_k(t-t_k)) \right. \\ &\quad \left. - \left[\rho_k - \beta_k \sin(\bar{\sigma}_k(\Omega_k(t-t_k) + \Delta_k^s) \right] \bar{\omega}_{n-1}(t) \right\} dt \end{aligned} \quad (5.5)$$

We may now state the following result.

Theorem 5.1 : Let $h > \bar{h}$ be such that the subsystems i , $1 \leq i \leq n-2$, possess closed orbits only. If the Melnikov integrals defined by equations (5.3) and (5.5) possess at least one transversal zero, then, for a sufficiently large machine M_n (i.e., for μ sufficiently small), Arnold diffusion arises on the energy level h .

Following remark 4 on p. 672 of Holmes and Marsden [26] (which is due to Weinstein) it is noted that transversal intersection of the perturbed stable and unstable manifolds of the invariant tori occurs for almost all Hamiltonian vector fields. We note that our system has a specific vector field even though there is a freedom to change parameters (e.g, ρ_j , β_j , etc.). Thus we must test explicitly if the Melnikov integral equations possess transversal zeros.

Remark: One may consider the Fourier expansion of the closed curves $\bar{\sigma}_k, \bar{\omega}_k$, $k = 1, \dots, n-2$, up to any integer J , as

$$\begin{aligned}\bar{\sigma}_k(\Omega_k(t-t_k)) &\approx \sum_{j=1}^j a_j \cos(j\Omega_k(t - \bar{t}_k)) \\ &\approx \sum_{j=1}^j a_j \left[\cos(j\Omega_k t) \cos(j\Omega_k \bar{t}_k) + \sin(j\Omega_k t) \sin(j\Omega_k \bar{t}_k) \right]\end{aligned}$$

and

$$\begin{aligned}\bar{\omega}_k(\Omega_k(t-t_k)) &\approx \sum_{j=1}^j -j\Omega_k a_j \sin(j\Omega_k(t - \bar{t}_k)) \\ &\approx \sum_{j=1}^j (-ja_j \Omega_k) \left[\sin(j\Omega_k t) \cos(j\Omega_k \bar{t}_k) - \sin(j\Omega_k \bar{t}_k) \cos(j\Omega_k t) \right].\end{aligned}$$

This expansion seems useful for computational purposes when the unperturbed solutions $\bar{\sigma}_k, \bar{\omega}_k$ are not available in a closed analytic form. Of course one should obtain an upper bound on the error for this approximation to be meaningful. In the case when the amplitude of the periodic solutions are very small one can approximate these solutions by the first terms of the Fourier expansion, with some small error term. This is treated next.

6. A Restricted Case to Small Oscillations

If one requires that the solution orbits of each unperturbed subsystem i , $1 \leq i \leq n-2$, is of a sufficiently small order of magnitude, then one can derive explicit conditions for a transversal zero.

Consider the original Hamiltonian equation (eqn. 4.12) (before scaling in α). Assume that α is sufficiently small and that the closed unperturbed solutions of each subsystem i , $1 \leq i \leq n-2$, is of order α in magnitude, i.e., one may substitute $\alpha\sigma_i$ (respectively, $\alpha\omega_i$) for σ_i (respectively, ω_i) for all $1 \leq i \leq n-2$. Let $\bar{\mu}_{n-1}$, $\mu_k = \mu$, $k = 1, \dots, n-2$. After cancellations and collections of terms we obtain.

$$\begin{aligned}H_\alpha^\mu &= \alpha \sum_{i=1}^{n-2} \frac{1}{2} \bar{M}_i \omega_i^2 + \alpha \sum_{i=1}^{n-2} \left[\frac{\bar{B}_i}{2} \cos(\Delta_i^s) \sigma_i^2 \right] \\ &+ \alpha^2 \sum_{i=1}^{n-2} \bar{B}_i \cos(\Delta_i^s) \left(\sigma_i \sum_{k=1}^{n-1} \mu \sigma_k \right) + O(\alpha^3 \mu^3) \\ &+ \frac{1}{2} \bar{M}_{n-1} \omega_{n-1}^2 - \bar{P}_{n-1} \left[\sigma_{n-1} + \alpha \sum_{k=1}^{n-1} \mu \sigma_k \right]\end{aligned}$$

$$-\bar{H}_{n-1} \left[\cos(\sigma_{n-1} + \Delta_{n-1}^s) - \cos(\Delta_{n-1}^s) - \alpha^2 \left(\sum_{k=1}^{n-1} \mu \sigma_k \right) \sin(\sigma_{n-1} + \Delta_{n-1}^s) + O(\alpha^1 \mu^s) \right] \\ + \frac{1}{2} \alpha^2 M_n^\infty \left[\sum_{k=1}^{n-1} \mu \omega_k \right]^2$$

where $l = 1$ and $s = 2$. We may write the Hamiltonian in a scaled form.

$$H_\alpha^\mu = \alpha \sum_{i=1}^{n-2} \frac{1}{2} \omega_i^2 + \alpha \sum_{i=1}^{n-2} \left[\beta_{in} \cos \Delta_i^s \right] \frac{\sigma_i^2}{2} \\ + \alpha^2 \sum_{i=1}^{n-2} \beta_{in} \cos(\Delta_i^s) \left(\mu \sigma_i \sum_{k=1}^{n-1} \sigma_k \right) + O(\alpha^1 \mu^s) \\ + \frac{1}{2} \omega_{n-1}^2 - \bar{\rho}_{n-1} \left[\sigma_{n-1} + \alpha \mu \sum_{k=1}^{n-1} \sigma_k \right] \\ - \beta_{n-1,n} \left[\cos(\sigma_{n-1} + \Delta_{n-1}^s) - \cos(\Delta_{n-1}^s) - \alpha^2 \left(\mu \sum_{k=1}^{n-1} \sigma_k \right) \sin(\sigma_{n-1} + \Delta_{n-1}^s) + O(\alpha^1 \mu^s) \right] \\ + \frac{1}{2} \alpha^2 \mu \left[\sum_{k=1}^{n-1} \omega_k \right]^2 \quad (6.1)$$

This formulation is particularly interesting since it resembles Arnold's first example of "Arnold diffusion" (see Arnold [11]). We shall show that the Hamiltonian, H_α^μ will meet all the requirements of section 2.

One may consider μ as a perturbation parameter which couples the Hamiltonian system, and α as a small (nonzero) parameter which measures the "size" of the neighborhood of the stable equilibrium point of the decoupled ($\mu = 0$) subsystem i , $1 \leq i \leq n-2$, within which solutions are restricted.

For a fixed $\alpha > 0$ set $\mu = 0$ to obtain the decoupled system. We note that the nonlinear oscillators are amplitude dependent due to higher order terms in α .

Again one may identify the subsystems as follows.

(a) the subsystem $n-1$ with Hamiltonian

$$F(\sigma_{n-1}, \omega_{n-1}) := \frac{1}{2} \omega_{n-1}^2 - \bar{\rho}_{n-1} \sigma_{n-1} - \beta_{n-1,n} \left[\cos(\sigma_{n-1} + \Delta_{n-1}^s) - \cos(\Delta_{n-1}^s) \right]$$

possesses a homoclinic orbit $(\bar{\sigma}_{n-1}, \bar{\omega}_{n-1})$ of energy level $F(\bar{\sigma}_{n-1}, \bar{\omega}_{n-1}) = \bar{h}$, and

(b) each subsystem i , $i = 1, \dots, n-2$, with Hamiltonian

$$G_i(\sigma_i, \omega_i) = \alpha \left(\frac{1}{2} \omega_i^2 + (\beta_{in} \cos(\Delta_i^s)) \frac{\sigma_i^2}{2} \right) + O(\alpha^2)$$

is a nonlinear oscillator. Note that $O(\alpha^2)$, which is independent of μ , is responsible for the amplitude dependent frequencies of which

$$\left(\beta_{in} \cos(\Delta_i^s) \right)^{1/2}$$

is the first term of the Taylor expansion.

(c) The coupling Hamiltonian is the following function of μ and α

$$\begin{aligned} H_\mu^1 = \mu H^1 &= \alpha^2 \sum_{i=1}^{n-2} \mu \beta_{in} \cos(\Delta_i^s) \sigma_i \sum_{k=1}^{n-1} \sigma_k \\ &\quad - \alpha \mu \bar{\rho}_{n-1} \sum_{k=1}^{n-1} \sigma_k + \alpha^2 \mu \sum_{k=1}^{n-1} \sigma_k \beta_{n-1,n} \sin(\sigma_{n-1} + \Delta_{n-1}^s) \\ &\quad + \frac{1}{2} \alpha^2 \mu \left[\sum_{k=1}^{n-1} \omega_k \right]^2 + O(\alpha^1 \mu^s) \end{aligned}$$

where $s = 2$ and $l = 1$.

We now compute the Melnikov integrals along a homoclinic orbit $(\bar{\omega}_1, \dots, \bar{\omega}_{n-1}, \bar{\sigma}_1, \dots, \bar{\sigma}_{n-1})$.

$$\begin{aligned} (1.i) \tilde{M}_1 &= \int_{-\infty}^{\infty} \left\{ G_i, H^1 \right\} dt \\ &= \int_{-\infty}^{\infty} \left[\bar{\omega}_1 \cdot \left[-\beta_{in} \cos(\Delta_i^s) \sum_{k=1}^{n-1} \bar{\sigma}_k \right] + \bar{\omega}_1 \cdot \left[-\sum_{j=1}^{n-2} \beta_{jn} \cos(\Delta_j^s) \bar{\sigma}_j \right] \right. \\ &\quad \left. + \bar{\omega}_1 \cdot \left[\bar{\rho}_{n-1} - \beta_{n-1,n} \sin(\bar{\sigma}_{n-1} + \Delta_{n-1}^s) \right] \right. \\ &\quad \left. + \left(\sum_{k=1}^{n-1} \bar{\omega}_k \right) (\beta_{in} \cos(\Delta_i^s) \bar{\sigma}_1) \right] dt \end{aligned} \tag{6.2.i}$$

Integrals of products of oscillators (subscripted $1 \leq i \leq n-2$) vanish as before, so (6.2.i) reduces to (see appendix A)

$$\tilde{M}_1 = \int_{-\infty}^{\infty} \left[(\beta_{in} \cos(\Delta_i^s)) \left[-\bar{\omega}_1 \bar{\sigma}_{n-1} + \bar{\omega}_{n-1} \bar{\sigma}_1 \right] + \bar{\omega}_1 \left[\bar{\rho}_{n-1} - \beta_{n-1,n} \sin(\bar{\sigma}_{n-1} + \Delta_{n-1}^s) \right] \right] dt$$

Noting that $\sigma_i = A_k \sin(\Omega_i t) + O(\alpha)$, first substitute in the Hamiltonian equation (6.1), then

rewrite the Melnikov integral as

$$\begin{aligned}
\tilde{M}_1 &= \int_{-\infty}^{\infty} \left\{ G_1, H^1 \right\} dt \\
&= (\beta_{1n} \cos(\Delta_1^s) \left[\left[\bar{\sigma}_{n-1} A_1 \cos(\Omega_1 t) \right]_{-\infty}^{\infty} \cos \Omega_1 t_1 + \left[\bar{\sigma}_{n-1} A_1 \sin(\Omega_1 t) \right]_{-\infty}^{\infty} \sin \Omega_1 t_1 \right] \\
&\quad + \left[\int_{-\infty}^{\infty} V_1 \left\{ -\Omega_1 A_1 \sin \Omega_1 t \right\} dt \right] \cos(\Omega_1 t_1) \\
&\quad - \left[\int_{-\infty}^{\infty} V_1 \left\{ -\Omega_1 A_1 \cos(\Omega_1 t) \right\} dt \right] \sin(\Omega_1 t_1)
\end{aligned} \tag{6.3.i}$$

where we have used

$$\frac{d}{dt} \bar{\sigma}_1 \bar{\sigma}_{n-1} = \bar{\omega}_1 \bar{\sigma}_{n-1} + \bar{\sigma}_1 \bar{\omega}_{n-1}$$

and

$$V_1 = -2(\beta_{1n} \cos(\Delta_1^s) \bar{\sigma}_{n-1} + \rho_{n-1} - \beta_{n-1,n} \sin(\bar{\sigma}_{n-1} + \Delta_{n-1}^s)).$$

Similarly, one computes the following Melnikov integral

$$\begin{aligned}
(2) \tilde{M}_{n-1} &= \int_{-\infty}^{\infty} \left\{ F, H^1 \right\} dt \\
&= \int_{-\infty}^{\infty} \left[\bar{\omega}_{n-1} \cdot \left[-\beta_{n-1,n} \cos(\bar{\sigma}_{n-1} + \Delta_{n-1}^s) \sum_{k=1}^{n-1} \bar{\sigma}_k - \sum_{j=1}^{n-2} (\beta_{jn} \cos \Delta_j^s) \bar{\sigma}_j \right. \right. \\
&\quad \left. \left. + (\rho_{n-1} - \beta_{n-1,n} \sin(\bar{\sigma}_{n-1} + \Delta_{n-1}^s)) \right] \right. \\
&\quad \left. - \left(\sum_{k=1}^{n-1} \bar{\omega}_k \right) \cdot (\bar{\rho}_{n-1} - \beta_{n-1,n} \sin(\bar{\sigma}_{n-1} + \Delta_{n-1}^s)) \right] dt
\end{aligned} \tag{6.4}$$

which, with $\rho_{n-1} := \bar{\rho}_{n-1}$ and $\beta_{n-1} := \beta_{n-1,n}$, reduces to (see appendix A)

$$\begin{aligned}
\tilde{M}_{n-1} &= \sum_{k=1}^{n-2} \int_{-\infty}^{\infty} \left[\frac{d}{dt} \left[\rho_{n-1} - \beta_{n-1} \sin(\bar{\sigma}_{n-1} + \Delta_{n-1}^s) \right] \bar{\sigma}_k \right. \\
&\quad \left. - \left[\rho_{n-1} - \beta_{n-1} \sin(\bar{\sigma}_{n-1} + \Delta_{n-1}^s) \right] \bar{\omega}_k - \beta_{kn} \cos(\Delta_k^s) \bar{\omega}_{n-1} \bar{\sigma}_k \right] dt
\end{aligned}$$

by direct computations and noting that $\sigma_k(t - t_k) = A_k \cos(t - t_k)$, one obtains

$$\begin{aligned}
\hat{M}_{n-1} &= \sum_{k=1}^{n-2} \left(\left[\rho_{n-1} - \beta_{n-1} \sin(\bar{\sigma}_{n-1} + \Delta_{n-1}^s) \right] A_k \cos \Omega_k t \right)_{-\infty}^{\infty} \cos \Omega_k t_k \\
&\quad + \left(\left[\rho_{n-1} - \beta_{n-1} \sin(\bar{\sigma}_{n-1} + \Delta_{n-1}^s) \right] A_k \sin \Omega_k t \right)_{-\infty}^{\infty} \sin \Omega_k t_k \\
&\quad + 2 \left[\int_{-\infty}^{\infty} \left[\rho_{n-1} - \beta_{n-1} \sin(\bar{\sigma}_{n-1} + \Delta_{n-1}^s) \right] \Omega_k A_k \sin \Omega_k t \, dt \right] \cos \Omega_k t_k \\
&\quad - 2 \left[\int_{-\infty}^{\infty} \left[\rho_{n-1} - \beta_{n-1} \sin(\bar{\sigma}_{n-1} + \Delta_{n-1}^s) \right] \Omega_k A_k \cos \Omega_k t \, dt \right] \sin \Omega_k t_k \\
&\quad - \left[\int_{-\infty}^{\infty} (\beta_{kn} \cos(\Delta_k^s)) \bar{\omega}_{n-1} A_k \cos(\Omega_k t) \, dt \right] \cos(\Omega_k t_k) \\
&\quad - \left[\int_{-\infty}^{\infty} (\beta_{kn} \cos(\Delta_k^s)) \bar{\omega}_{n-1} A_k \sin(\Omega_k t) \, dt \right] \sin(\Omega_k t_k)
\end{aligned} \tag{6.5}$$

From appendix (A) and eqn. (6.3.i) one obtains

$$\hat{M}_1(t_1) = a_{11} \cos \Omega_1 t_1 + b_{11} \sin \Omega_1 t_1 \tag{6.6.i}$$

where a_{11}, b_{11} are nonzero constants for all except a discrete set of frequencies Ω_i . Thus, \hat{M}_1 has isolated zeros in t_1 (two in each period $2(\frac{\pi}{\Omega_i})$) Also at these (isolated) discrete zeros,

$\frac{\partial \hat{M}_1}{\partial t_1} \neq 0$. Indeed, we set $\hat{M}_1 = 0$ in (6.6.i) to obtain

$$\tan(\Omega_1 t_1^*) = -\frac{a_{11}}{b_{11}} \tag{6.7.i}$$

Let us define $\sin(\Omega_1 t_1^*) = -\frac{a_{11}}{[a_{11}^2 + b_{11}^2]^{1/2}}$. Eqn (6.7.i) gives

$$\Omega_1 t_1^* = -\tan^{-1}\left(\frac{a_{11}}{b_{11}}\right) + \text{mod}(\pi) \tag{6.8.i}$$

Thus

$$\frac{\partial \hat{M}_1}{\partial t_1}(t_1^*) = -a_{11} \Omega_1 \sin \Omega_1 t_1^* + \Omega_1 b_{11} \cos \Omega_1 t_1^*$$

$$\frac{\partial \hat{M}_1}{\partial t_1}(t_1^*) = \Omega_1 \left[\sqrt{a_{11}^2 + b_{11}^2} \right] \neq 0$$

Therefore, for almost all frequencies Ω_j , $\tilde{M}_j(t_j^*) = 0$ and $\frac{\partial \tilde{M}_j}{\partial t_j}(t_j^*) \neq 0$ on the set

$$\left\{ t_j^* \in \mathbb{R} \mid (6.8.i) \text{ is satisfied} \right\} \quad (6.9.i)$$

From appendix A and equation (6.5) it follows that

$$\tilde{M}_{n-1}(t_1, \dots, t_{n-3}, t_{n-2}) = \sum_{k=1}^{n-2} a_{n-1,k} \cos(\Omega_k t_k) + b_{n-1,k} \sin(\Omega_k t_k) \quad (6.10)$$

where $a_{n-1,k}$, $b_{n-1,k}$ are nonzero for all k , $1 \leq k \leq n-2$.

To obtain a transversal zero for the $(n-2)$ -vector \tilde{M} we observe that

$$\tilde{M}(t_1, \dots, t_{n-2}) = (\tilde{M}_1, \dots, \tilde{M}_{n-3}, \tilde{M}_{n-1})^t$$

has the Jacobian determinant

$$\det[D\tilde{M}] = \prod_{k=1}^{n-3} \frac{\partial \tilde{M}_k}{\partial t_k} \cdot \frac{\partial \tilde{M}_{n-1}}{\partial t_{n-2}} \quad (6.11)$$

This follows since \tilde{M}_k is a function only of t_k , $k = 1, \dots, n-3$, hence the Jacobian matrix $D\tilde{M}$ is a lower triangular matrix. Thus, if a transversal zero t_k^* of each \tilde{M}_k , $k = 1, \dots, n-3$ is substituted into (5.10), then one would only require that the Melnikov function of (6.10) possess a transversal zero in the variable t_{n-1} . In this way, (6.11) will be trivially satisfied and it then follows that the vector \tilde{M} has a transversal zero.

To establish these claims, First substitute in (6.10) the transversal zeros $t_1^*, t_2^*, \dots, t_{n-3}^*$ of \tilde{M}_k , $k = 1, \dots, n-3$ and obtain

$$\tilde{M}_{n-1} = a_{n-1,n-2} \cos \Omega_{n-2} t_{n-2} + b_{n-1,n-2} \sin \Omega_{n-2} t_{n-2} + \sum_{k=1}^{n-3} \frac{a_{n-1,k} b_{k1} - b_{n-1,k} a_{k1}}{(a_{k1}^2 + b_{k1}^2)^{\frac{1}{2}}}$$

where we have used the following two equalities obtained from equation (6.7),

$$\sin(\Omega_k t_k^*) = - \frac{a_{k1}}{(a_{k1}^2 + b_{k1}^2)^{\frac{1}{2}}} \quad \text{and} \quad \cos(\Omega_k t_k^*) = + \frac{b_{k1}}{(a_{k1}^2 + b_{k1}^2)^{\frac{1}{2}}}$$

Thus for $\tilde{M}_{n-1} = 0$, one requires

$$\begin{bmatrix} a_{n-1,n-2} & b_{n-1,n-2} \end{bmatrix} \begin{bmatrix} \cos \Omega_{n-2} t_{n-2} \\ \sin \Omega_{n-2} t_{n-2} \end{bmatrix} = \sum_{k=1}^{n-3} \frac{a_{k1} b_{n-1,k} - b_{k1} a_{n-1,k}}{(a_{k1}^2 + b_{k1}^2)^{\frac{1}{2}}} \quad (6.12)$$

Taking derivatives of (6.10) with respect to t_{n-2} ,

$$\frac{\partial \tilde{M}_{n-1}}{\partial t_{n-2}} = \Omega_{n-2} \begin{bmatrix} b_{n-1,n-2} & -a_{n-1,n-2} \end{bmatrix} \begin{bmatrix} \cos \Omega_{n-2} t_{n-2} \\ \sin \Omega_{n-2} t_{n-2} \end{bmatrix} \quad (6.13)$$

To ensure that (6.13) does not vanish, we require that

$$\begin{bmatrix} \cos \Omega_{n-2} t_{n-2} \\ \sin \Omega_{n-2} t_{n-2} \end{bmatrix} \neq k_1 \begin{bmatrix} a_{n-1,n-2} \\ b_{n-1,n-2} \end{bmatrix} \quad (6.14)$$

where $k_1 \in \mathbb{R}$, thus

Theorem 6.1 : If equations (6.12) and (6.14) are satisfied for some (t_{n-2}) then, for a sufficiently large n -th machine (M_n) , Arnold diffusion arises in the Hamiltonian system (6.1) on every energy level $h > \bar{h}$ and h is near \bar{h} .

We note that equations (6.12) and (6.14) are in fact satisfied by discrete values of t_{n-2} .

If one requires that the sum in (6.12) vanishes, one obtains the following condition,

$$\begin{bmatrix} \cos \Omega_{n-2} t_{n-2} \\ \sin \Omega_{n-2} t_{n-2} \end{bmatrix} = k_2 \begin{bmatrix} b_{n-1,n-2} \\ -a_{n-1,n-2} \end{bmatrix}$$

where k_2 is a nonzero real constant. Then equation (6.13) becomes

$$\frac{\partial \tilde{M}_{n-1}}{\partial t_{n-1}} = k_2 \Omega_{n-2} \left[(b_{n-1,n-2})^2 + (a_{n-1,n-2})^2 \right] \neq 0$$

Therefore a sufficient condition for the Melnikov vector \tilde{M} to possess a transversal zero is

$$\sum_{k=1}^{n-3} \frac{a_{k1} b_{n-1,k} - b_{k1} a_{n-1,k}}{(a_{k1}^2 + b_{k1}^2)^{\frac{1}{2}}} = 0 \quad (\text{AA})$$

or equivalently (using equation (6.12))

$$\tan(\Omega_{n-2} t_{n-2}) = - \frac{a_{n-1,n-2}}{b_{n-1,n-2}}. \quad (\text{BB})$$

We state the following

Corollary: If equation (AA), (or (BB)), holds, then for sufficiently large machine (M_n), Arnold diffusion arises in the Hamiltonian system (6.1) on infinitely many energy levels $h > \bar{h}$.

7. Conclusions

Theorems 5.1 and 6.1 can be extended to the case when the small parameter ε (see section 4.) is nonzero. This is possible as long as ε is in the order of μ^2 (i.e., $O(\varepsilon) = O(\mu^2)$) and thus it will have no effect on the existence of transversal zeros. This follows since the Melnikov method respects only the first terms of a perturbed solution expansion in a power series in μ .

Our results ensure the presence of horseshoes (and hence chaotic orbits) in the special case of the two degree of freedom swing equations (three machines). This is similar to the case considered by Kopell and Washburn [29].

Holmes and Marsden [26] have developed a technique which may be employed to show that, on certain energy surfaces, Arnold diffusion can survive suitable positive and negative damping perturbations. It would be interesting to see if this technique can be applied in the case of the linear damping of the swing equations (i.e., $D_i \neq 0$).

We finally summarize our conclusions and suggestions for future work in the following.

- (A) Theoretical work: (1) In Melnikov integrals for n degree of freedom systems terms due only to products of oscillators may arise. These terms are not a measure of the separation between stable and unstable manifolds. They, rather, measure asynchronous distance between the oscillators. This phenomena, found by the present authors, needs to be explored more systematically.
- (2) The Melnikov approach can be extended to consider more terms in the approximation of the separation between the stable and unstable manifolds. This seems appropriate from applications point of view since it is tuned for computations.
- (3) Allowing for certain positive and negative damping in the theory of Arnold diffusion has been mentioned in Holmes and Marsden [25,26]. The affects of damping needs to be explored

for the case of the classical model of power systems.

(B) Applications: (1) Many model systems in the physical sciences and engineering exist which satisfy the conditions of the theorems on chaotic behavior or Arnold diffusion. One needs to test for the presence of complicated dynamics of these models. For example, a study of the Josephson junction circuit (with negligible damping) can be conducted on similar lines to our approach.

(2) Computer simulations would verify the presence of complex irregular dynamics in the swing equations under the conditions provided in section 4. Moreover they would display these dynamics for possible further studies. In the case of periodic but not necessarily small oscillators, tests can be conducted computationally.

(3) The effects of a small amount of damping should be studied. This allows for a more realistic modeling of many engineering systems.

(4) For large perturbations (large μ) one can get many other effects, such as collision of non-resonant tori (see [1] and the references therein). The systematic exploration of these would be useful for many engineering systems in general and power systems in specific.

B. Appendix A

The simplification of the Melnikov integrals for small amplitude oscillations

We perform explicit calculations to first show that the integrals of a product of variables of oscillators over the infinite integral domain vanish. Second we show that integrals of products of oscillator variables with the homoclinic orbit variables (subscripted $n-1$) result in equations (6.6.i) and (6.10).

Equation (6.6.i) Case 1 Products of Oscillator Variables

From equation (6.2.i) we note that the products of oscillator variables are composed of the following basic integral.

$$\Psi = \int_{-\infty}^{\infty} \bar{\omega}_i(t-t_i) \bar{\sigma}_k(t-t_k) dt \quad (\text{A.1})$$

where the bar denotes the unperturbed solutions given by

$$\alpha \bar{\sigma}_k(t) = \alpha A_k \cos \Omega_k t + O(\alpha^2)$$

$$\alpha \bar{\omega}_i(t) = -\alpha A_i \Omega_i \sin \Omega_i t + O(\alpha^2)$$

where α is sufficiently small. Perform a change of integration variables on (A.1) and obtain

$$\Psi = \int_{-\infty}^{\infty} \bar{\omega}_i(\tau+t_k-t_i) \bar{\sigma}_k(\tau) d\tau$$

For $i=k$, $t_k = t_i$ and so

$$\begin{aligned} \Psi &= \int_{-\infty}^{\infty} \bar{\omega}_i(\tau) \bar{\sigma}_k(\tau) d\tau = \int_{-\infty}^{\infty} -A_k^2 \Omega_k \sin(\Omega_k \tau) \cos(\Omega_k \tau) d\tau \\ &= C_k \int_{-\infty}^{\infty} \frac{1}{2} \sin(2\Omega_k \tau) d\tau = \lim_{L \rightarrow \infty} \frac{C_k}{2} [\cos(L) - \cos(-L)] = 0 \end{aligned}$$

Note that we have substituted the first terms of the expressions for the unperturbed solutions. The error terms, $O(\alpha^2)$ are included in the higher order terms that do not affect the Melnikov integrals. To see this, first substitute the small oscillation variables in the Hamiltonian function and thus the $O(\alpha^2)$ term will be collected with the higher order terms. Now rewrite the Melnikov integrals.

For $k \neq i$, let $t_i^* = t_k - t_i$, then

$$\begin{aligned} \Psi &= \int_{-L}^L -A_i A_k \Omega_i \sin \Omega_i (\tau + t_i^*) \cos(\Omega_k \tau) d\tau \\ &= \frac{-A_i A_k \Omega_i}{2} \int_{-L}^L \left[\sin[(\Omega_i + \Omega_k)\tau + \Omega_i t_i^*] + \sin[(\Omega_i - \Omega_k)\tau + \Omega_i t_i^*] \right] d\tau \end{aligned}$$

To obtain conditional convergence and for a fixed i and k , write

$$\begin{aligned} \Psi &= A_i A_k \frac{\Omega_i}{2} \lim_{L \rightarrow \infty} \left\{ \frac{\cos[(\Omega_i + \Omega_k)\tau + \Omega_i t_i^*]}{\Omega_i + \Omega_k} \Big|_{-L}^L \right. \\ &\quad \left. + \frac{\cos[(\Omega_i - \Omega_k)\tau + \Omega_i t_i^*]}{\Omega_i - \Omega_k} \Big|_{-L}^L \right\} \end{aligned}$$

Let

$$\Psi_1 = \frac{\cos[(\Omega_1 + \Omega_k)\tau + \Omega_1 t_1^*]}{\Omega_1 + \Omega_k} \Big|_{-L}^L$$

and

$$\Psi_2 = \frac{\cos[(\Omega_1 - \Omega_k)\tau + \Omega_1 t_1^*]}{\Omega_1 - \Omega_k} \Big|_{-L}^L$$

We claim that there is a sequence L_n of values of L converging to ∞ such that $\Psi = 0$.

To see this, write

$$\begin{aligned} \Psi_1 &= \frac{1}{(\Omega_1 + \Omega_k)} \left\{ \cos[(\Omega_1 + \Omega_k)L] \cos \Omega_1 t_1^* - \sin[(\Omega_1 + \Omega_k)L] \sin \Omega_1 t_1^* \right. \\ &\quad \left. - \left[\cos[-(\Omega_1 + \Omega_k)L] \cos \Omega_1 t_1^* - \sin[-(\Omega_1 + \Omega_k)L] \sin \Omega_1 t_1^* \right] \right\} \\ &= \frac{1}{(\Omega_1 + \Omega_k)} \left\{ -2 \sin[(\Omega_1 + \Omega_k)L] \sin \Omega_1 t_1^* \right\} \end{aligned}$$

Similarly

$$\begin{aligned} \Psi_2 &= \frac{1}{(\Omega_1 - \Omega_k)} \left\{ \cos[(\Omega_1 - \Omega_k)L] \cos \Omega_1 t_1^* - \sin[(\Omega_1 - \Omega_k)L] \sin \Omega_1 t_1^* \right. \\ &\quad \left. - \left[\cos[-(\Omega_1 - \Omega_k)L] \cos \Omega_1 t_1^* - \sin[-(\Omega_1 - \Omega_k)L] \sin \Omega_1 t_1^* \right] \right\} \\ &= \frac{1}{(\Omega_1 - \Omega_k)} \left\{ -2 \sin[(\Omega_1 - \Omega_k)L] \sin \Omega_1 t_1^* \right\} \end{aligned}$$

Then consider

$$\begin{aligned} \bar{\Psi} &= (\Omega_1 + \Omega_k)(\Omega_1 - \Omega_k)\Psi \\ &= A \left\{ (\Omega_1 - \Omega_k) \sin[(\Omega_1 + \Omega_k)L] + (\Omega_1 + \Omega_k) \sin[(\Omega_1 - \Omega_k)L] \right\} \sin \Omega_1 t_1^* \end{aligned}$$

$$\begin{aligned} \bar{\Psi} &= A \sin \Omega_1 t_1^* \left\{ (\Omega_1 - \Omega_k) \left[\sin \Omega_1 L \cos \Omega_k L + \cos \Omega_1 L \sin \Omega_k L \right] \right. \\ &\quad \left. + (\Omega_1 + \Omega_k) \left[\sin \Omega_1 L \cos \Omega_k L - \cos \Omega_1 L \sin \Omega_k L \right] \right\} \end{aligned}$$

$$\bar{\Psi} = A \sin \Omega_1 t_1^* \left\{ \sin \Omega_1 L \cos \Omega_k L (\Omega_1 - \Omega_k + \Omega_1 + \Omega_k) \right.$$

$$\begin{aligned}
& + \cos\Omega_i L \sin\Omega_k L (\Omega_i - \Omega_k - \Omega_i - \Omega_k) \Big\} \\
= & 2A \sin\Omega_i t_i \left\{ \Omega_i (\sin\Omega_i L \cos\Omega_k L) - \Omega_k (\cos\Omega_i L \sin\Omega_k L) \right\}
\end{aligned}$$

Consider the quantity in braces

$$\left\{ \Omega_i \sin\Omega_i L \cos\Omega_k L - \Omega_k \cos\Omega_i L \sin\Omega_k L \right\}$$

which we equate with zero and obtain

$$\tan(\Omega_i L) = \frac{\Omega_k}{\Omega_i} \tan(\Omega_k L).$$

A simple sketch of these functions shows that there exist a sequence L_n of time, $L_n \rightarrow \infty$, values at which the equality holds. (Rational independence of the frequencies is sufficient for the existence of this sequence).

Case 2 A product of a homoclinic and oscillator variables

The basic product components of the Melnikov integral (6.2.i) are as follows

$$\int_{-\infty}^{\infty} \bar{\omega}_1(\tau - t_i) \bar{\omega}_{n-1}(\tau) d\tau \tag{A.2a}$$

$$\int_{-\infty}^{\infty} \bar{\omega}_{n-1}(\tau) \bar{\omega}_1(\tau - t_i) d\tau \tag{A.2b}$$

$$\int_{-\infty}^{\infty} \bar{\omega}_1(\tau - t_i) \dot{\bar{\omega}}_{n-1}(\tau) d\tau \tag{A.2c}$$

where t_i is the initial phase.

$$(A.2c) = \lim_{L \rightarrow \infty} \left\{ \left[\bar{\omega}_1(\tau - t_i) \bar{\omega}_{n-1}(\tau) \right]_{-L}^L - \int_{-L}^L \bar{\omega}_1 \bar{\omega}_{n-1} d\tau \right\}$$

Noting that $\lim_{L \rightarrow \infty} \bar{\omega}_{n-1}(\pm L) = 0$ (the velocity component of the saddle of the homoclinic orbit equals zero), then

$$(A.2.c) = \lim_{L \rightarrow \infty} \left\{ - \int_{-L}^L \bar{\omega}_1 \dot{\bar{\omega}}_{n-1} d\tau \right\}$$

$$= \lim_{L \rightarrow \infty} - \left\{ \left[\dot{\bar{\omega}}_i(\tau - t_i^*) \bar{\sigma}_{n-1}(\tau) \right]_{-L}^L - \int_{-L}^L \frac{d}{d\tau} \dot{\bar{\omega}}_i(\tau - t_i^*) \bar{\sigma}_{n-1}(\tau) d\tau \right\}$$

Again the first limit goes to zero. First note that

$$\begin{aligned} \bar{\omega}_i(\tau - t_i^*) &= -A_i \Omega_i \sin(\Omega_i(\tau - t_i^*)) \\ &= \bar{\omega}_i(\tau) \cos(\Omega_i t_i^*) + \Omega_i \bar{\sigma}_i(\tau) \sin \Omega_i t_i^* \end{aligned}$$

and

$$\bar{\sigma}_i(\tau - t_i^*) = A_i \cos(\Omega_i(\tau - t_i^*)) = \left[\bar{\sigma}_i(\tau) \cos(\Omega_i t_i^*) + \frac{1}{\Omega_i} \dot{\bar{\omega}}_i(\tau) \sin(\Omega_i t_i^*) \right]$$

where we neglected the error terms which do not affect the Melnikov integrals. Then the first term of (A.2c) becomes

$$\begin{aligned} \lim_{L \rightarrow \infty} \int_{-L}^L \dot{\bar{\omega}}_i(\tau - t_i^*) \bar{\sigma}_{n-1}(\tau) d\tau &= -\Omega_i^2 \lim_{M \rightarrow \infty} \int_{\frac{-M + t_i^*}{\Omega_i}}^{\frac{M + t_i^*}{\Omega_i}} \bar{\sigma}_{n-1}(\tau) \bar{\sigma}_i(\tau - t_i^*) d\tau \\ &= \lim_{M \rightarrow \infty} A_i \left\{ \cos(M) \bar{\sigma}_{n-1}\left(\frac{M + t_i^*}{\Omega_i}\right) - \bar{\sigma}_{n-1}\left(\frac{-M + t_i^*}{\Omega_i}\right) \cos(-M) \right\} \\ &= \lim_{M \rightarrow \infty} A_i A_i \left[\bar{\sigma}_{n-1}\left(\frac{M + t_i^*}{\Omega_i}\right) - \bar{\sigma}_{n-1}\left(\frac{-M + t_i^*}{\Omega_i}\right) \right] \cos M \end{aligned} \quad (\text{A.3})$$

where we wrote $A_i \cos \Omega_i \tau$ for $\bar{\sigma}_i(\tau)$. Note that $\bar{\sigma}_{n-1}$ is the component of the homoclinic orbit such that

$$\lim_{M \rightarrow \infty} \bar{\sigma}_{n-1}(\pm M) = \bar{\sigma}_{n-1}(\pm \infty) = (\pi - 2\Delta_{n-1}^s),$$

where the saddle point is $(\pi - 2\Delta_{n-1}^s, 0)$, and hence (A.3) vanishes. Therefore,

$$\begin{aligned} (\text{A.2c}) &= \int_{-\infty}^{\infty} \frac{d}{d\tau} \dot{\bar{\omega}}_i(\tau - t_i^*) \bar{\sigma}_{n-1}(\tau) d\tau = -\Omega_i^2 \int_{-\infty}^{\infty} \bar{\omega}_i(\tau - t_i^*) \bar{\sigma}_{n-1}(\tau) d\tau \\ &= -\Omega_i^2 (\text{A.2a}). \end{aligned}$$

Thus the basic terms are those of (A.2a) and (A.2b).

The integral of (A.2b) is treated the same way,

$$\int_{-\infty}^{\infty} \bar{\omega}_{n-1}(\tau) \bar{\sigma}_i(\tau - t_i^*) d\tau = \lim_{N \rightarrow \infty} \int_{\frac{-N}{\Omega_i}}^{\frac{N}{\Omega_i}} \bar{\omega}_{n-1}(\tau) \bar{\sigma}_i(\tau - t_i^*) d\tau$$

$$- \int_{-\infty}^{\infty} \bar{\sigma}_{n-1}(\tau) \bar{\omega}_i(\tau - t_i^*) d\tau \quad (\text{A.4})$$

where the first term vanishes (see A.3) and hence (A.4) reduces to (the negative of) the integral in (A.2a). Thus

$$\begin{aligned} (\text{A.2a}) = \int_{-\infty}^{\infty} \bar{\omega}_i(\tau - t_i^*) \bar{\sigma}_{n-1}(\tau) d\tau &= \left\{ \int_{-\infty}^{\infty} \bar{\sigma}_{n-1}(\tau) \bar{\omega}_i(\tau) d\tau \right\} \cos \Omega_i t_i^* \\ &+ \left\{ \Omega_i \int_{-\infty}^{\infty} \bar{\sigma}_{n-1}(\tau) \bar{\sigma}_i(\tau) d\tau \right\} \sin \Omega_i t_i^* \end{aligned}$$

where each integral in the braces is well-defined and is a nonzero constant for all except a discrete set of Ω_i (see Kopell and Washburn [29] or Holmes and Marsden [27]).

Collecting terms and noting that the coefficients of these integrals are different due to the different parameters M_j, B_j etc., one obtains the following

$$\bar{M}_j(t_j) = a_{j1} \cos \Omega_j t_j^* + b_{j1} \sin \Omega_j t_j^*$$

where a_{j1} and b_{j1} are nonzero constants for all except a discrete set of Ω_j .

Equation (6.10)

The terms of the integrand of equation (6.4) are composed of the following expressions.

$$\frac{d}{dt} \left[\rho_{n-1} - \beta_{n-1,n} \sin(\bar{\sigma}_{n-1} + \Delta_{n-1}^s) \right] \bar{\sigma}_{n-1} \quad (\text{A.5.a})$$

$$\frac{d}{dt} \left[\rho_{n-1} - \beta_{n-1,n} \sin(\bar{\sigma}_{n-1} + \Delta_{n-1}^s) \right] \bar{\sigma}_k \quad 1 \leq k \leq n-2 \quad (\text{A.5.b})$$

$$\bar{\omega}_{n-1} \bar{\sigma}_k \quad 1 \leq k \leq n-2 \quad (\text{A.5.c})$$

$$\left[\rho_{n-1} - \beta_{n-1,n} \sin(\bar{\sigma}_{n-1} + \Delta_{n-1}^s) \right] \bar{\omega}_{n-1} \quad (\text{A.5.d})$$

$$\left[\rho_{n-1} - \beta_{n-1,n} \sin(\bar{\sigma}_{n-1} + \Delta_{n-1}^s) \right] \bar{\omega}_k = (\dot{\omega}_{n-1}) \bar{\omega}_k \quad (\text{A.5.e})$$

We first consider the terms with vanishing integrals over the infinite domains; namely (A.5.a) and (A.5.d).

Consider the integral of (A.5.a) and perform integration by parts.

$$\begin{aligned}
& \int_{-\infty}^{\infty} \frac{d}{dt} \left[\rho_{n-1} - \beta_{n-1,n} \sin(\bar{\sigma}_{n-1} + \Delta_{n-1}^s) \right] \bar{\sigma}_{n-1} d\tau \\
&= \lim_{N \rightarrow \infty} \left\{ \bar{\sigma}_{n-1}(\tau) \left[\rho_{n-1} - \beta_{n-1,n} \sin(\bar{\sigma}_{n-1}(\tau) + \Delta_{n-1}^s) \right] \right|_{-N}^N \\
&\quad - \int_{-L}^L \left[\rho_{n-1} - \beta_{n-1,n} \sin(\bar{\sigma}_{n-1}(\tau) + \Delta_{n-1}^s) \right] \bar{\omega}_{n-1}(\tau) d\tau \right\}
\end{aligned}$$

The first term vanishes as $N \rightarrow \infty$ since

$$\lim_{N \rightarrow \infty} \left[\rho_{n-1} - \beta_{n-1,n} \sin(\bar{\sigma}_{n-1}(N) + \Delta_{n-1}^s) \right] = \lim_{N \rightarrow \infty} \dot{\bar{\omega}}_{n-1}(N) = 0.$$

where $\bar{\omega}_{n-1}(\pm\infty)$ is a component of the saddle

$$(\bar{\sigma}_{n-1}(\pm\infty), \bar{\omega}_{n-1}(\pm\infty)) = (\bar{\sigma}_{n-1}(\pm\infty), 0).$$

Thus the term of eqn (A.5.a) is the same (except for a minus sign) as the term of eqn (A.5.d).

Consider now the integral of (A.5.d)

$$\begin{aligned}
& \int_{-\infty}^{\infty} \left[\rho_{n-1} - \beta_{n-1,n} \sin(\bar{\sigma}_{n-1} + \Delta_{n-1}^s) \right] \bar{\omega}_{n-1}(\tau) d\tau \\
&= \int_{-\infty}^{\infty} \dot{\bar{\omega}}_{n-1}(\tau) \bar{\omega}_{n-1}(\tau) d\tau = \frac{1}{2} \lim_{N \rightarrow \infty} \bar{\omega}_{n-1}^2(\tau) \Big|_{-N}^N = 0.
\end{aligned}$$

That is, the 'kinetic' energy at the saddle, referenced to itself, is equals to zero. Hence the terms of (A.5.a) and (A.5.d) produce vanishing integrals.

The term of eqn.(A.5.c) is the same as the one in equation (A.4). The terms of (A.5.b) and (A.5.e) are the same if one performs integration by parts on (A.5.e).

Thus it is left only to consider the term (A.5.b) for a given k , $1 \leq k \leq n-2$,

$$\begin{aligned}
\int_{-\infty}^{\infty} (A.5.b) d\tau &= \int_{-\infty}^{\infty} \frac{d}{dt} \left[\rho_{n-1} - \beta_{n-1,n} \sin(\bar{\sigma}_{n-1} + \Delta_{n-1}^s) \right] \bar{\sigma}_k(t - t_k) dt \\
&= \int_{-\infty}^{\infty} \frac{d}{dt} \left[\dot{\bar{\omega}}_{n-1} \right] \bar{\sigma}_k(t - t_k) dt.
\end{aligned}$$

Noting that

$$\begin{aligned}
\bar{\sigma}_k(t - t_k) &= A_k \cos \Omega_k(t - t_k) \\
&= A_k \left[\cos \Omega_k t_k \cos \Omega_k t_k + \sin \Omega_k \sin \Omega_k t_k \right]
\end{aligned}$$

then the integral becomes

$$\int_{-\infty}^{\infty} (A.5.b) d\tau = \left[A_k \int_{-\infty}^{\infty} \frac{d}{dt} (\dot{\tilde{w}}_{n-1}) \cos \Omega_k t dt \right] \cos \Omega_k t_k \\ + \left[A_k \int_{-\infty}^{\infty} \frac{d}{dt} (\dot{\tilde{w}}_{n-1}) \sin \Omega_k t dt \right] \sin \Omega_k t_k$$

We note that no cancellations between the intergal terms in eqn. (6.4) can occur since the coefficients of the integrals are different for different parameters. Define

$$a_{n-1,k} = A_k \int_{-\infty}^{\infty} \frac{d}{dt} (\dot{\tilde{w}}_{n-1}(t)) \cos \Omega_k t dt$$

and

$$b_{n-1,k} = A_k \int_{-\infty}^{\infty} \frac{d}{dt} (\dot{\tilde{w}}_{n-1}(t)) \sin \Omega_k t dt$$

where $a_{n-1,k}$ and $b_{n-1,k}$ are well-defined and vanish only for a set of discrete values of Ω_k . This follows from the analyticity of the integrals in Ω_k with the rate of acceleration term (i.e.,

$\frac{d}{dt} \dot{\tilde{w}}_{n-1}(t)$) is nonvanishing along the homoclinic orbit (see Kopell and Washburn [29] or

Holmes and Marsden [27]).

References

- [1] Abdel Salam, F., J. Marsden, and P. Varaiya "Chaos and Arnold Diffusion in Dynamical Systems", *IEEE, CAS* November 1983.
- [2] Abdel Salam, F., Chaos and Arnold Diffusion in Dynamical Systems with Applications to Power Systems, **Ph.D. thesis** in electrical engineering, UC Berkeley, Dec 1982.
- [3] Abdel Salam, F. "Analytic Expressions for the unstable manifold of dynamical systems of differential equations", **Masters thesis** in mathematics, UCB Dec 1982.
- [4] Abed, E. and P. Varaiya "Oscillations in power systems via Hopf bifurcation", *Proc. of the 20th IEEE C.D.C.*, Dec. 1981, San Diego, Ca.
- [5] Abraham, R. and J. E. Marsden, **Foundations of Mechanics**. 2nd Edition, Reading, MA: Benjamin, 1978.
- [6] Anderson, P. M. and A. A. Fouad, **Power System Control and Stability, Volume 1**. Ames, IO: The Iowa State University Press, 1977.
- [7] Andronov, A. A. and C. E. Chaikin, **Theory of Oscillations**. Princeton, N.J.: Princeton University Press, 1949.
- [8] Arapostathis, A., S. Sastry and P. Varaiya, "Analysis of the Power Flow Equations", *Electrical Energy and Power Systems*, vol. 3 (3), 1981, 116-126.
- [9] Arapostathis, A., S. Sastry, P. Varaiya, "Global Analysis of Swing Dynamics", *IEEE Transactions on Circuits and Systems*, October 1982.
- [10] Arapostathis, and P. Varaiya, "The Behavior of Three Node Power Networks", *Electric Energy and Power Systems*, January 1983.
- [11] Arnold, V. I., "Instability of dynamical systems with several degrees of freedom", *Dokl. Akad. Nauk. SSSR* 158:9-12, 1964
- [12] Arnold, V. I., **Mathematical Methods of Classical Mechanics**. Berlin-Heidelberg: Springer-Verlag, 1978.
- [13] Athay, T., R. Podmore and S. Virmani, "A Practical Method for the Direct Analysis of

- Transient Stability", *IEEE Transactions on Power Apparatus and Systems*, vol. PAS-98 (1979), pp. 573-584.
- [14] Athay, T., V. Sherkat, R. Podmore, S. Virmani and C. Puegh, "Transient Energy Stability Analysis", Systems Engineering for Power Conference, Davos, Switzerland, October 1979.
- [15] Aylett, P. D., "The Energy Integral Criterion of Transient Stability Limits of Power Systems", *Proceedings IEE (London)*, vol. 105(C), pp. 527-536, 1958.
- [16] Bailleul, J. and C. I. Byrnes, "Geometric Critical Point Analysis of Lossless Power System Models", *IEEE Transactions on Circuits and Systems*, November 1982, to appear.
- [17] Brockett, R. W., "ON the Asymptotic Properties of Solutions of Differential Equations with Multiple Equilibria", *Journal of Differential Equations*, Vol. 44, number 2, may 1982, pp. 249-262.
- [18] El-Abiad, A. H. and K. Nagappan, "Transient Stability Regions of Multimachine Power Systems", *IEEE Transactions on Power Apparatus and Systems*, vol. PAS-85 (1966), pp. 169-179.
- [19] Fouad, A. A., "Stability Theory - Criteria for Transient Stability", in *Systems Engineering of Power: Status and Prospects* (ed. L. H. Fink and K. Carlson), U.S. ERDA and ERPI, 1975, pp. 421-450.
- [20] Fouad, A. A. and S. E. Stanton, "Transient Stability of a Multimachine Power System, Part I: Investigation of System Trajectories; Part II: Critical Transient Energy", *IEEE Transactions on Power Apparatus and Systems*, vol. PAS-100 (1981), pp. 3408-3424.
- [21] Gudar, U., "A General Lyapunov Function for Multi-Machine Power Systems with Transfer Conductances", *Int. J. Control*, 1975, vol. 21, No. 2, pp. 333-343.
- [22] Gupta, C. L. and A. H. El-Abiad, "Determination of the Closest Unstable Equilibrium State for Lyapunov Methods in Transient Stability Studies", *IEEE Transactions on Power Apparatus and Systems*, vol. PAS-94 (1976), pp. 1699-1712.
- [23] Hill, D. J. and A. R. Bergen, "Stability Analysis of Multimachine Power Networks with Linear Frequency Dependent Loads", Memo. UCB/ERL M81/5, Electronics Research Lab., Univ. of California, Berkeley, CA, December 1980.
- [24] Holmes, P. "Averaging and chaotic motions in forced oscillations", *SIAM. J. on Appl. Math.*, vol. 38, 68-80 and 40, 167-168.(1980).
- [25] Holmes, P. J. and J. E. Marsden, "Horseshoes in perturbations of Hamiltonian systems with two degrees of freedom" *Communication on Mathematical Physics* Vol. 82, 1982, pp. 523-544.
- [26] Holmes, P. J. and J. E. Marsden, "Melnikov's method and Arnold diffusion for perturbations of integrable Hamiltonian systems ", *Journal of Mathematical Physics*. Vol. 23 no. 4, 1982, pp. 669-679.
- [27] Holmes, P. J. and J. E. Marsden, "Horseshoes and Arnold diffusion for Hamiltonian systems on Lie groups", *Indiana University Mathematical Journal* (March/April 1983).
- [28] Kakimoto, N., Ohsawa, Y., Hayashi, M., "Transient Stability Analysis of Electric Power Systems via Lure' Type Lyapunov Function." "Part I. New Critical Value for Transient Stability." pp. 62-71. "Part II. Modification of Lure' Type Lyapunov Function with Effect of Transfer Conductances." pp. 72-79. Trans. IEE of Japan, Vol. 98, No. 516, May/June 1978.
- [29] Kopell, N., and R. B. Washburn, Jr., "Chaotic Motions in the Two Degree-of-Freedom Swing Equations", *IEEE Transactions on Circuits and Systems*, November 1982, to appear.
- [30] Korsak, A., "On the Question of Uniqueness of Stable Load-Flow Solutions", *IEEE Transactions on Power Apparatus and Systems*, vol. PAS-91 (1972), pp. 1033-1100.
- [31] Luders, G. A., "Transient Stability of Multimachine Power Systems via the Direct Method of Lyapunov", *IEEE Transactions on Power Apparatus and Systems*, vol. PAS-90 (1971), pp. 23-36.
- [32] Pai, M. A. and P. G. Murthy, "On Lyapunov Functions for Power Systems with Transfer Conductances", *IEEE Trans. Automatic Control*, vol. AC-18, pp. 181-183, April 1973.
- [33] Pai, M. A., "Some Mathematical Aspects of Power System Stability by Lyapunov's Method", International Conference on "Electric Power Problems: The Mathematical

- Challenge", sponsored by SIAM, Seattle, Washington, March 18-20, 1980.
- [34] Prabhakara, F. S. and A. H. El-Abiad, "A Simplified Determination of Transient Stability Regions for Lyapunov Methods", *IEEE Transactions on Power Apparatus and Systems*, vol. PAS-94 (1975), pp. 872-889.
 - [35] Ribbens-Pavella, M. "Critical Survey of Transient Stability Studies of Multimachine Power Systems by Lyapunov's Direct Method", *Proc. 9th Allerton Conf. on Circuit and System Theory*, October 6-8, 1971, pp. 751-761.
 - [36] Ribbens-Pavella, M., Comments on J. L. Willems "Direct Methods for Transient Stability Studies in Power System Analysis", and Reply by Author, *IEEE Trans. Automatic Control*, vol. AC-17, pp. 415-417, June 1972.
 - [37] Ribbens-Pavella, M., A. Calvaer and J. Gheury, "Transient Stability Index for On-Line Evaluation", IEEE PES Winter Meeting, New York, NY, February 3-8, 1980.
 - [38] Skar, S. J., "Stability of Multi-Machine Power Systems with Nontrivial Transfer Conductances", *SIAM J. Appl. Math.*, Vol. 39, No. 3, December 1980.
 - [39] Tavora, C. J. and O. J. M. Smith, "Equilibrium Analysis of Power Systems", *IEEE Transactions on Power Apparatus and Systems*, vol. PAS-91 (1972), pp. 1131-1137.
 - [40] Tavora, C. J. and O. J. M. Smith, "Stability Analysis of Power Systems", *IEEE Transactions on Power Apparatus and Systems*, vol. PAS-91 (1972), pp. 1138-1144.
 - [41] Van Ness, J. E., F. M. Brasch, Jr., G. L. Landgren and S. I. Naumann, "Analytical Investigation of Dynamic Instability Occuring at Powerton Station", *IEEE Transactions on Power Apparatus and Systems*, vol. PAS-99 (1980), pp. 1386-1395.
 - [42] Willems, J. L., "The Computation of Finite Stability Regions by means of Open Lyapunov Surfaces", *Int. J. Control*, 1969, vol. 10, No. 5, pp. 537-544.
 - [43] Willems, J. L., "Direct Methods for Transient Stability Studies in Power System Analysis", *IEEE Trans. Automatic Control*, Vol. AC-16, No. 4, August 1971.
 - [44] Willems, J. L., "A Partial Stability Approach to the Problem of Transient Power System Stability", *Int. J. Control*, 1974, vol. 19, No. 1, pp. 1-14.

Figure Captions

- Fig 1 A sample power system; generators, transmission network, and loads.
- Fig 2 The power system diagram (our model).
- Fig 3 The phase portrait of a pendulum with constant forcing.
- Fig 4 A homoclinic orbit (subsystem $n-1$).
- Fig 5 Closed orbits of a pendulum (subsystem i , $1 \leq i \leq n-2$).

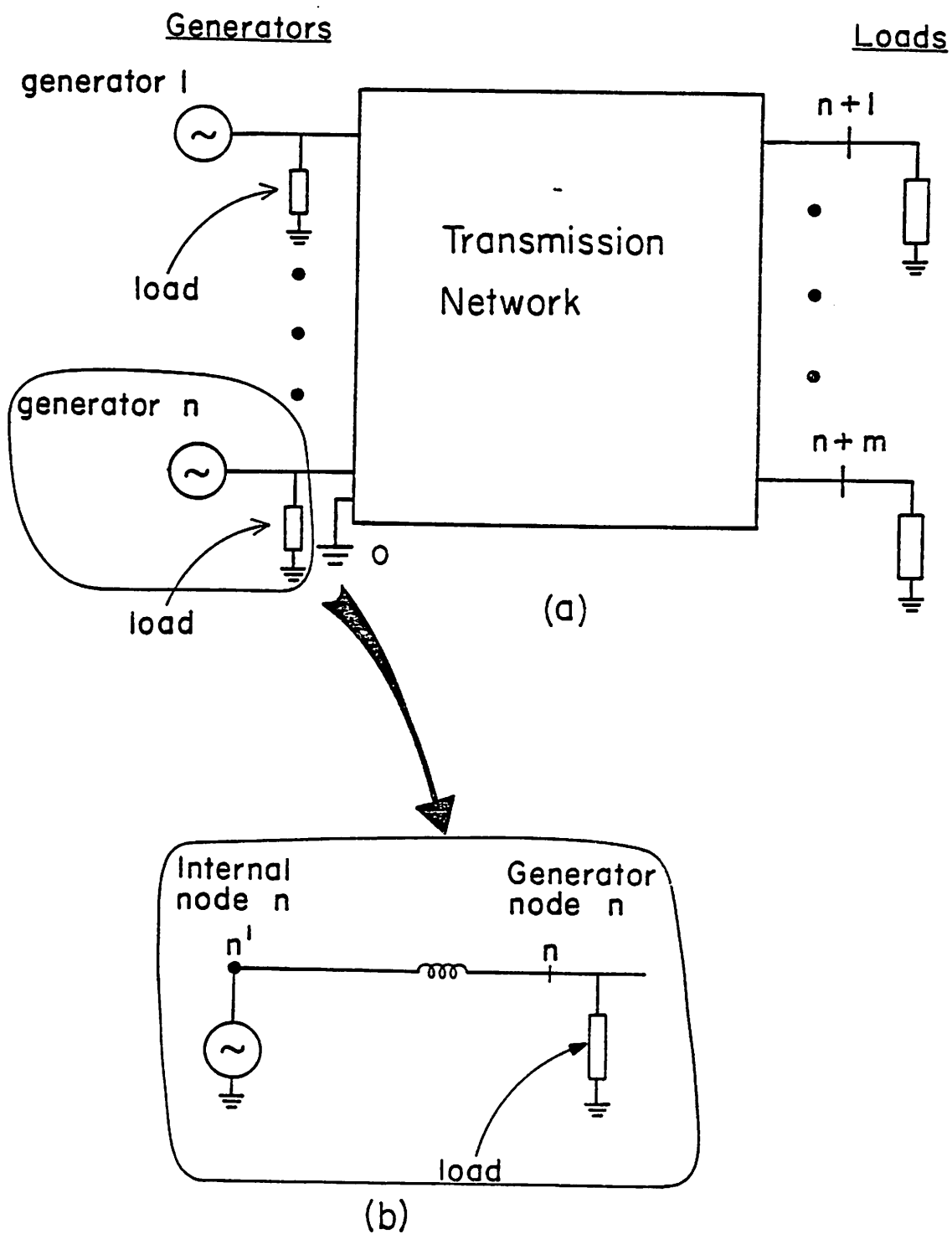

Fig. 1. A sample power system; generators, transmission network, and loads.

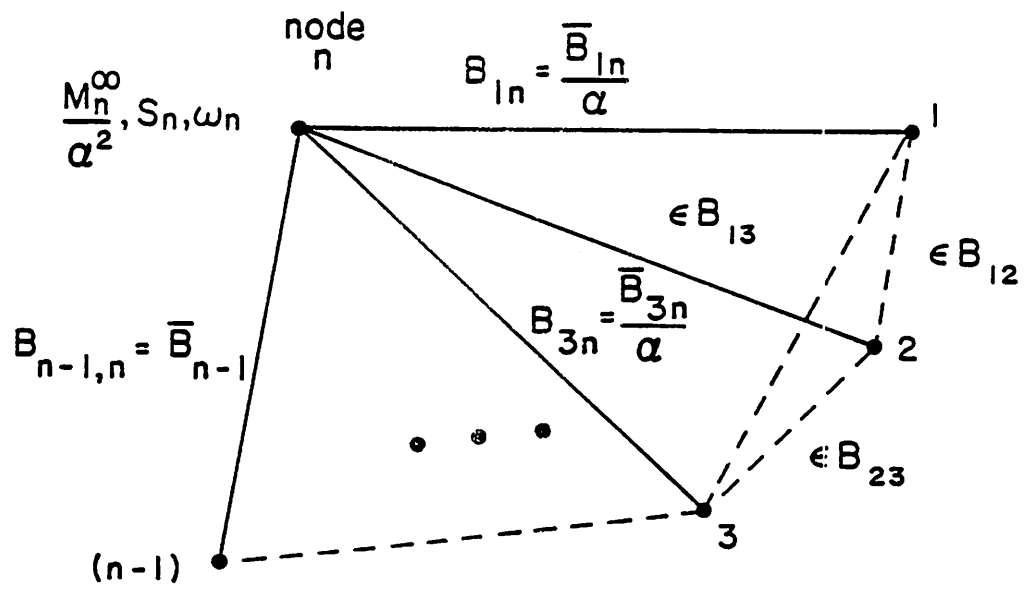

Fig. 2 The power system diagram (our model).

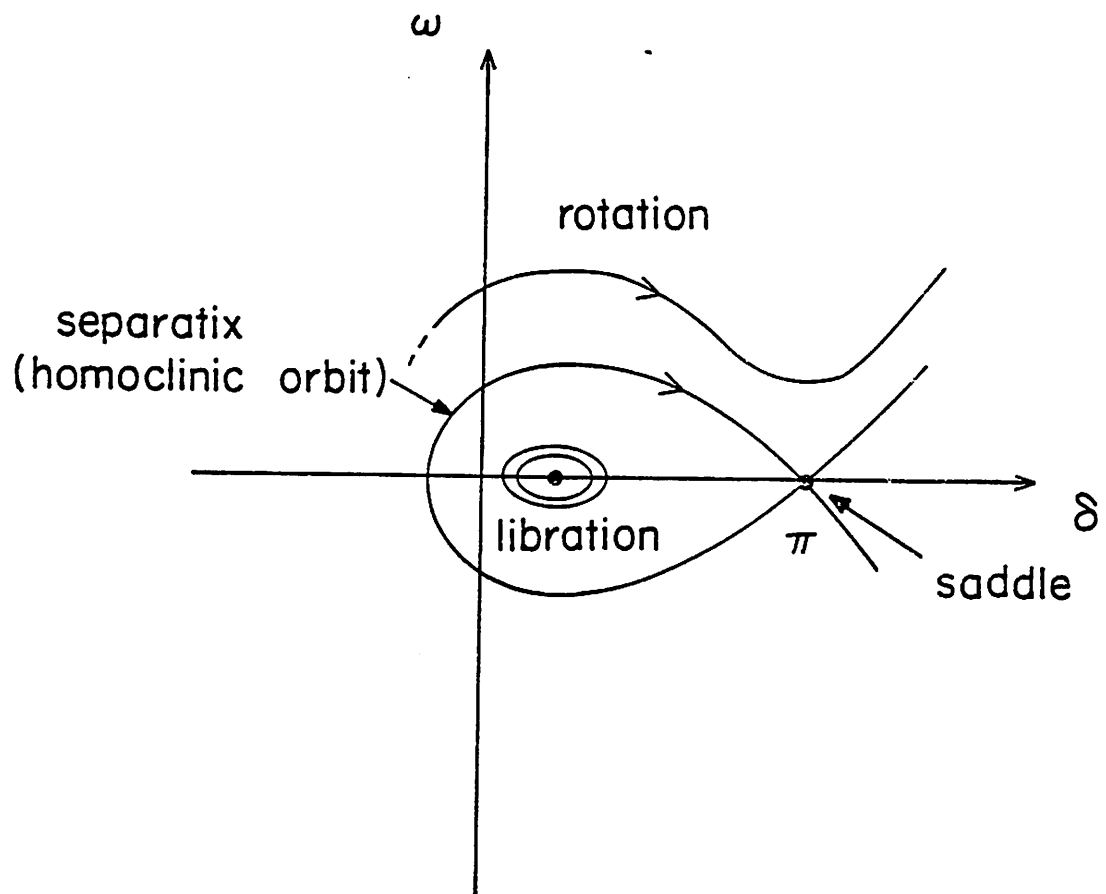

Fig. 3 The phase portrait of a pendulum with constant forcing.

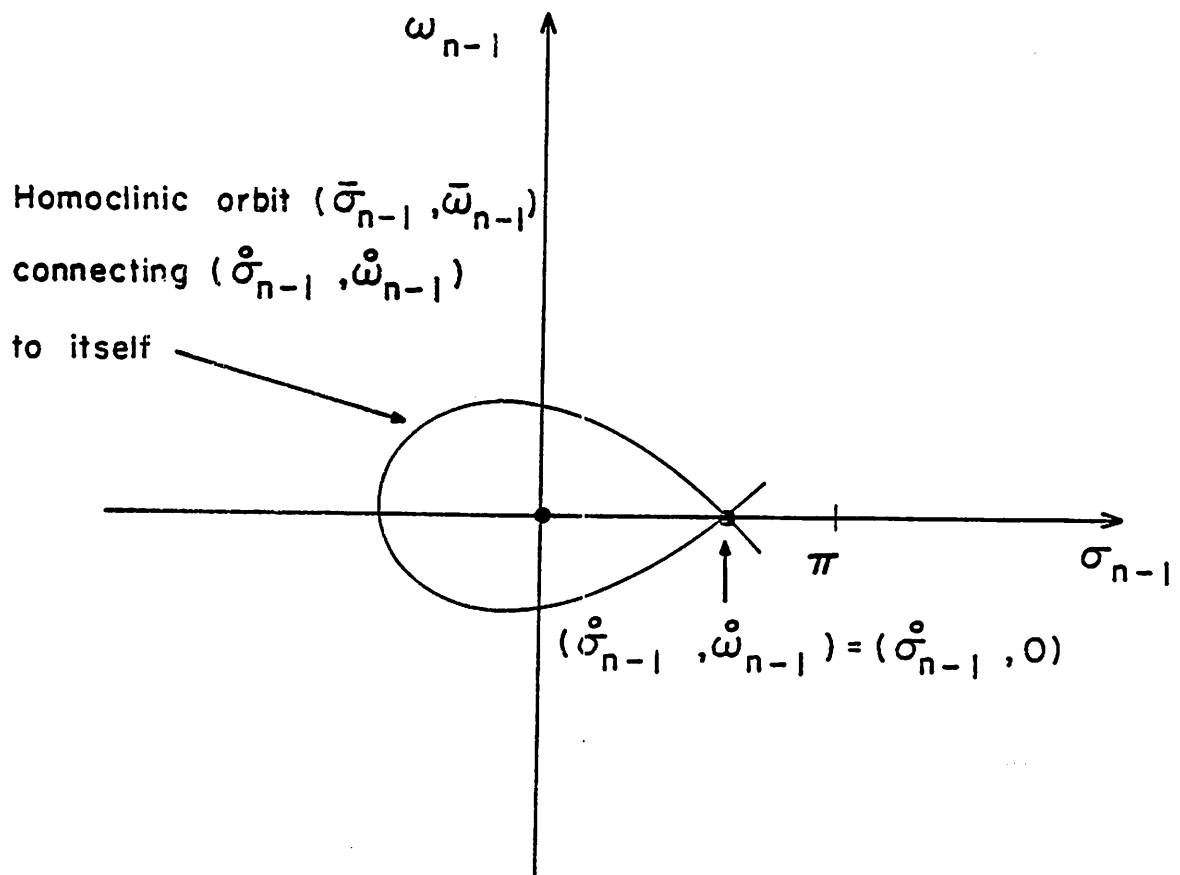

Fig. 4 A homoclinic orbit of a pendulum
 (subsystem n-1).

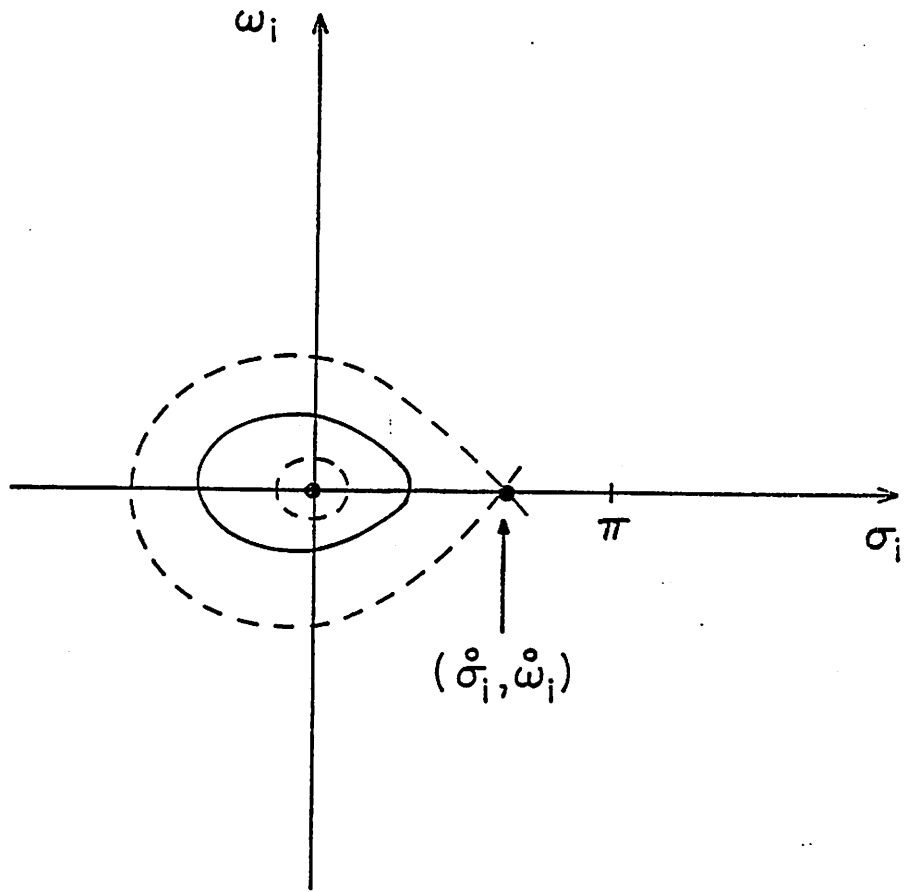

Fig. 5. Closed orbits of a pendulum (subsystem i , $1 \leq i \leq n-2$).