

Copyright © 1983, by the author(s).  
All rights reserved.

Permission to make digital or hard copies of all or part of this work for personal or classroom use is granted without fee provided that copies are not made or distributed for profit or commercial advantage and that copies bear this notice and the full citation on the first page. To copy otherwise, to republish, to post on servers or to redistribute to lists, requires prior specific permission.

STABILITY, SECURITY AND RELIABILITY  
OF INTERCONNECTED POWER SYSTEMS

by  
Felix F. Wu

Memorandum No. UCB/ERL M83/67

19 September 1983

ELECTRONICS RESEARCH LABORATORY  
College of Engineering  
University of California, Berkeley  
94720

# STABILITY, SECURITY, AND RELIABILITY OF INTERCONNECTED POWER SYSTEMS\*

Felix F. Wu

Department of Electrical Engineering and Computer Science,  
and the Electronics Research Laboratory,  
University of California, Berkeley, California 94720

## ABSTRACT

The objective of a power system is to supply customer load demand economically and reliably. The ability of a power system to supply load demand while the operating constraints are all satisfied is termed reliability in the planning context and security in the operating context. The constraints may be divided into steady-state constraints and dynamic constraints after a disturbance. In steady-state operation, the power generation and the load demand must be balanced. This is represented mathematically by the power flow equations. The solution of the power flow equations can be used to check whether the operating limits are met in the system. The dynamic response of the system after a disturbance must be stable. In this paper the state-of-the-art and current research in reliability and security of large interconnected power systems are reviewed. Reliability evaluation and security assessment involve power flow studies and stability analysis. Recent developments in the numerical simulation and analytical studies of power flow and power system stability are first reviewed in this paper.

---

This paper was prepared for the invited talk given at the *Stocker Conference on Large Scale Interconnected Systems*, Oct. 10-11, 1983, Athens, Ohio. It will be published in *Large Scale Systems: Theory and Applications*

## 1. INTERCONNECTED POWER SYSTEMS

### 1.1. Structure

A power system is an interconnected system composed of several utilities' generating stations which convert fuel energy into electricity, substations that distribute power to consumers, and transmission lines that tie the generation stations and distribution substations together. Interconnection allows electric utilities to share resources, thus reducing overall costs and improving reliability. The power system is conveniently divided into generation, transmission, and distribution subsystems. Central to the generation subsystem is the synchronous generator. The rotor of the synchronous machine is driven mechanically by steam produced in a thermal unit (coal, gas, nuclear), or water from a hydro unit. The synchronous machine converts mechanical power input to the rotor into electrical power output of the generator. The transmission subsystem is a highly meshed network of high-voltage transmission lines which carry electric power from the generators to the distribution substations. The distribution subsystem receives power from a substation and distributes it to the customers through a radial lower-voltage network. For study of interconnected systems, the distribution subsystem is treated as an aggregate load demand at the substation. The interconnected generation-transmission system with aggregate load demands is commonly called *bulk power system*.

Disturbances, small and large, occur frequently on power systems. A typical small disturbance is the load fluctuation. Generators are equipped with a feedback control system called the automatic generation control (AGC) system to control the mechanical power input in response to the continuously changing load demand. Short circuit caused by lightning, for example, is considered a large disturbance, or *fault*. Generator failure is also considered a large disturbance. Protective relays are placed strategically throughout the system to

detect the occurrence of a large disturbance and to trigger the opening of circuit breakers so that the affected equipment (e.g., shorted transmission line) can be isolated.

## 1.2. Constraints

### *Power Flow*

In steady-state operation the power generated by the generators and the load demands of the customers must be balanced. The mathematical equations describing the power balance are called *power flow*, or *load flow*, equations. The system must be operated so that there is no overload on the equipment and no abnormal voltages throughout the systems. These constraints can be expressed mathematically in terms of the load flow variables.

### *Stability*

Dynamic response of the generators must be taken into account when disturbances are involved. The system has to be stable after a disturbance. Two types of stability are considered. *Small-disturbance stability* refers to the asymptotic stability of the operating point. *Transient stability* refers to the stability of the post-fault system after a fault is cleared.

## 1.3. Operating Objective

The operating objective of a power system is to serve the load demand economically and reliably, with all the constraints satisfied.

## 1.4. Failure Events

The failure to satisfy the operating constraints may lead to load curtailment (loss of load) or system collapse. Fig. 1 shows major system failure sequences. The initiating events of system failure are the outage of a generator or a transmission line (may be caused by lightning). The system failure events are the loss of load and system collapse. The blocks in between represent

system response.

System failure events can be roughly divided into two cases, one is due to violation of steady-state constraints (Fig. 2), and the other due to violation of dynamic constraints (Fig. 3).

### 1.5. Reliability and Security

In planning and operation, one is concerned with the ability of the system to serve load demand in the presence of disturbances. In the planning context this is called *reliability*, and in the operation context this is called *security*. This double-line of defense is necessary because for planning, a much longer time period, a large number of possible operating conditions and disturbances have to be considered, whereas for operation, only the current situation and imminent disturbances are of concern, and more information about them is available. However the methods for the analysis of reliability and security are intimately related.

### 1.6. Contents of the Paper

This paper reviews the state-of-the-art methods and current research for reliability evaluation and security assessment of interconnected power systems. Power flow and stability analyses, which are two major components in reliability evaluation and security assessment, are also reviewed.

## 2. POWER FLOW

### 2.1. Modeling

The steady-state operation of an electric power supply system requires that the power supply and the load demand must be balanced. This is described by a set of nonlinear equations known as the *power flow*, or load flow, equations. Furthermore, the system has to be operated within the designed limits of the

equipments. This is described by a set of inequality constraints, sometimes referred to as the *security constraints*. The fundamental problem in the steady-state analysis of power systems is to determine, for a given set of load demand and generation pattern, whether the system can be operated in such a way that all the equipments are loaded within their security constraints.

The branches of a power network represent transmission lines, transformers, etc., which are modeled as linear time-invariant *RLC* elements. The nodes of the network other than the ground node are called *buses*. They correspond to generation stations and load-center substations. For steady-state analysis the network is considered as in sinusoidal steady-state.

*Power flow equations*

Consider a power network with  $N + 1$  buses. Let  $[Y]$  denote the  $(N+1) \cdot (N+1)$  node(bus) admittance matrix of the network and  $Y_{ki} = G_{ki} + jB_{ki}$  be its  $k$ ith element. Let  $E_k$  denote the bus voltage phasor of bus  $k$  and  $S_k = P_k + jQ_k$  denote the injected complex voltages and complex power injections, respectively. For convenience, we introduce a diagonal matrix  $[E] = \text{diag}\{E_1, E_2, \dots, E_N\}$ . Then we have

$$S^* = [E^*][Y]E \quad (1)$$

where superscript \* denotes complex conjugate. There are three types of buses:

- (i) *Slack bus*: a bus whose voltage magnitude and phase angle are specified;
- (ii) *PQ bus*: a bus where the injected real and reactive power are specified;
- (iii) *PV bus*: a bus where the injected real power and the voltage magnitude are specified.

Load buses are modeled as PQ buses. Generator buses are modeled as PV buses, except one generator bus is chosen as the slack bus. We let subscript 0

correspond to the slack bus, subscripts  $\{1,2,\dots,N_Q\}$  correspond to PQ buses and subscripts  $\{N_Q+1, \dots, N\}$  correspond to PV buses. Let  $E_k = V_k e^{j\theta_k}$  and  $\theta_{ki} = \theta_k - \theta_i$ . We may express (1) as

$$\sum_{i=0}^N V_k V_i (G_{ki} \sin \theta_{ki} - B_{ki} \cos \theta_{ki}) = Q_k, \quad k = 1, 2, \dots, N_Q \quad (2)$$

$$\sum_{i=0}^N V_k V_i (G_{ki} \cos \theta_{ki} + B_{ki} \sin \theta_{ki}) = P_k, \quad k = 1, 2, \dots, N \quad (3)$$

where  $\mathbf{V} = (V_1, V_2, \dots, V_N)^T$  and  $\boldsymbol{\theta} = (\theta_1, \theta_2, \dots, \theta_N)^T$  are the unknown variables or the state variables, and  $\mathbf{Q} = (Q_1, \dots, Q_{N_Q})^T$  and  $\mathbf{P} = (P_1, \dots, P_N)^T$  are the power injections. Equations (2) and (3) are known as the *power flow*, or load flow, equations. For ease of later reference we represent (2) and (3) in the form

$$f(\mathbf{x}) = \mathbf{y} \quad (4)$$

where  $\mathbf{x} = (\mathbf{V}, \boldsymbol{\theta})$  is the set of state variables and  $\mathbf{y} = (\mathbf{Q}, \mathbf{P})$  is the set of power injections.

#### *Decoupled Power Flow Equations*

Suppose that we make the following simplifying assumptions:

(SA1) The line resistances are negligible, i.e.,  $G_{ki} = 0$ .

(SA2) The phase angles across the branches  $\theta_{ki} = \theta_k - \theta_i$  are small so that the second and higher order terms in the series expansions of  $\sin \theta_{ki}$  and  $\cos \theta_{ki}$  are negligible, i.e.,  $\cos \theta_{ki} \approx 1, \sin \theta_{ki} \approx \theta_{ki}$ .

Then the power flow equations (2), (3) become the decoupled power flow equations:

$$Q_k = Q_k(\mathbf{V}) = -V_k \sum_{i=0}^N B_{ki} V_i, \quad k = 1, 2, \dots, N_Q \quad (5)$$

$$P_k = P_k(\mathbf{V}, \boldsymbol{\theta}) = V_k \sum_{i=0}^N B_{ki} V_i (\theta_k - \theta_i), \quad k = 1, 2, \dots, N. \quad (6)$$



### *Real Power Flow Equations*

For the analysis of real power flows during transient, the sine term in Eq. (6) is retained. Indeed the following nonlinear real power flow equations are used in transient stability studies:

$$P_k = V_k \sum_{i=0}^N B_{ki} V_i \sin(\theta_k - \theta_i), \quad k = 1, 2, \dots, N \quad (7)$$

Eq. (7) may be obtained from Eq. (3) by assuming transmission lines are lossless ( $G_{ki} = 0$ ). A further approximation of Eq. (6) is obtained by assuming that the voltage magnitudes are all constant equal to one, the resulting equations are called DC load flow equations:

$$P_k = \sum_{i=0}^N B_{ki} (\theta_k - \theta_i), \quad k = 1, 2, \dots, N \quad (8)$$

### 2.2. Numerical Simulation

The conventional approach to the steady-state analysis of power systems is to solve the power flow equations numerically and then check whether the security constraints are satisfied. Newton-Raphson [1] and Fast Decoupled [2] methods are the two commonly used solution algorithms. A comprehensive review of the numerical simulation approach to the power flow study is provided by Stott [3]. The convergence properties have been analyzed from both numerical studies [3] and a few theoretical investigations [4-5]. Fifteen hundred or two thousand bus system power flows are routinely solved in industry [3].

The application of multiprocessors for power flow solutions has been investigated by Pottle et. al. [6-7].

### 2.3. Analytic Studies

The conditions for the existence of power flow solutions was studied by Galiana [8-9], who has also studied other aspects of analytic properties of power flow equations. An example of multiple solutions using realistic system

data was given by Johnson [10]. More examples of multiple solutions can be found in [11-12].

For the real power flow equations (7), the non-uniqueness of solution was observed by Korsak [13]. Power flow solution of a three-node network was first studied by Tavora and Smith [14]. The real power flow equations (7) are analyzed more thoroughly by Arapostathis, Sastry, Varaiya [15-17], Baillieul, Byrnes [18-20].

Consider again the power flow equation (4),

$$f(\mathbf{x}) = \mathbf{y} \quad (9)$$

The system in steady-state has to be operated without equipment overload and abnormal voltages. These constraints may be expressed in terms of inequalities:

$$g(\mathbf{x}) \leq 0 \quad (10)$$

Wu and Kumagai [21] defined the *steady-state security region* (Fig. 4) for the given system configuration to be the set of  $\mathbf{y}$  for which there exists a solution to the power flow equation (9) satisfying the security constraints (10). By the application of analytic degree theory, they have obtained explicit expressions for the steady-state security regions. Previously the steady-state security regions using the linear dc load flow equations are obtained [22-24].

## 2.4. Related Topics

### *Power Flow Approximations*

An analytic study of various approximations (decoupled power flow, linearized decoupled power flow, adjoint-network sensitivity equations) of the power flow equations is presented by Kaye and Wu [25].

### *Power Flow External Equivalents*

Usually for power flow analysis, one is interested in the response in ones own area, however, because of the interconnection, the external system has to be included in the study. A comprehensive review of external network modeling for power flow studies is provided by Wu and Monticelli [26].

### *Optimal Power Flow*

The optimal power flow problem concerns with the search of a power flow solution by varying the generation pattern so that the total system production cost, or transmission losses, is minimized [27-30]. Nonlinear programming formulations have been applied.

## **3. STABILITY**

### **3.1. Modeling**

In studying the stability of a power system, the dynamics of synchronous machines and their interaction with the power flows in the network must be considered. For the electrical interaction with the power network, the simplest model of the synchronous machine for stability analysis is the so-called classical machine model, consisting of a voltage source in series with an impedance. The synchronous machine is an electromechanical energy conversion device. The power output from the voltage source in the machine model and the mechanical power input to the machine are related to rotor dynamics. The dynamic equation describing the motion of the rotor is called the *swing equation* of the machine.

$$M_i \dot{\omega}_i + d_i \omega_i = P_i - P_{ei} \quad (11)$$

where

$M_i$  : generator inertia constant

$\omega_i = \dot{\theta}_i$  : generator speed with respect to the synchronous speed

$d_i$  : generator damping coefficient

$P_i$  : mechanical power input

and

$$P_{\text{net}} = \sum_k V_i V_k B_{ik} \sin(\theta_i - \theta_k) - V_i V_k G_{ik} \cos(\theta_i - \theta_k) \quad (12)$$

is the sum of real power flows to the network from the generator.

A differential equation describing the dynamic response of the voltage  $V_i$  of the classical machine model (effect of field flux decay) may be added. More elaborate machine models include the differential equations representing the effect of damper windings, rotor iron currents, etc.. The dynamic response of control devices, i.e., excitation systems, turbine-governor systems, etc., are included for more detailed models. The power network is usually represented by the power flow equations. For more details on machine modeling, the readers should consult ref. [31].

At any rate the resulting dynamic model of the power system may be represented by a nonlinear vector differential equation.

$$\dot{\mathbf{x}} = \mathbf{F}(\mathbf{x}, \mathbf{y}) \quad (13)$$

where  $\mathbf{y}$  is the set of injections or power generation and load demand, and  $\mathbf{x}$  is the set of state variables, including  $\theta_i, \omega_i$ , etc.

The equilibrium points, or the operating points, of (13) are the solution of  $\mathbf{F}(\mathbf{x}, \mathbf{y}) = 0$ . In fact, the operating point is a steady-state solution; or a solution of the power flow equations  $\mathbf{f}(\mathbf{x}) = \mathbf{y}$ .

#### *Small-Disturbance Stability*

Small disturbance such as load fluctuation, happens all the time on a power system. An operating point, therefore, is required to be asymptotically stable, which is called small-disturbance (SD) stable in power literature.

### *Transient Stability*

Suppose that a large disturbance (a fault) occurs on the system. The result of a fault may be short-circuit on a transmission line. In the pre-fault configuration, the power system is in a steady-state condition. The fault occurs say at  $t = 0$  and the system is then in the fault-on condition for a fixed time period  $\tau$ , during which the state of the system changes dynamically. The fault is then "cleared" by protective relay system operation, which opens the circuit breakers to disconnect the faulted line, thus moving the system to its post-fault configuration. The state of the system then changes according to different dynamics, the initial condition of which is the value of the fault-on state, at the instant of fault clearing. If this initial state of the post-fault system is in the region of attraction of the post-fault equilibrium operating point, then the system is transiently stable.

The pre-fault system is described by the power flow equations:

$$f_i(x_0) = y. \quad (14)$$

The fault-on system is described by a set of differential equations from 0 to  $\tau$ , where  $\tau$  is the switching time,

$$\dot{x}_1 = F_k(x_1, y). \quad (15)$$

The post-fault dynamics are

$$\dot{x}_2 = F_j(x_2, y). \quad (16)$$

### 3.2. Numerical Simulation

Detailed model of synchronous machine and the associated control systems are normally used for numerical simulation. For the analysis of small-disturbance stability, eigenvalues of the linearized state equations (13) are calculated [32-33]. For the analysis of transient stability, time-domain step-by-step solution of the state equation (13) is computed. Implicit trapezoidal

formula is the most popular algorithm in use. A complete survey of transient stability simulation is provided by Stott [34]. Programs with capability of handling two thousand buses three hundred generators are routinely used. Typically ten to forty runs may be required for a plan and CPU time may be 15 minutes for a typical run. The analysis of results is done by engineering judgement. The recent trend is to simulate a longer time period, hence dynamics of boiler, etc. are included [35].

The application of multiprocessing to transient stability simulation has been investigated by Van Ness, Brasch et. al. [36-37].

### 3.3. Analytic Studies

Very simple models are used for analytic studies of dynamic behavior of power systems. Swing equation (11) for synchronous machine and decoupled real power flow equation (7) for the network are normally used.

#### *Small-disturbance stability*

The stability of the equilibrium points, which are the solutions to the real power flow equations (7) have been studied [15-20, 38, 56]. Wu and Liu [39] have included the reactive power flow equations (2) into the model (with  $G_{ki} = 0$ ) for small-disturbance stability analysis.

#### *Nonlinear behavior*

The application of bifurcation theory to the swing-equation real-power-flow model of power system [15,19-20,40-41] have revealed interesting properties of the model. Abed, Tsolas, Varaiya [40-41] have shown, using Hopf bifurcation theorem that an operating point can lose its stability due to a number of factors. Kopell and Washburn [42] have shown the presence of chaotic motion in the three-machine model. More general case is studied by Abdel Salam, Marsden and Variaya [43].

### *Direct method for transient stability evaluation*

The application of Liapunov direct method for transient stability evaluation of power system has been suggested for some time, see Fouad [44], Pai [45], Ribbens-Pavella and Evans [46]. The work by Athay, Podmore, Virmani [47] using the so-called transient energy function demonstrated the practical feasibility of the approach. Michel, Fouad and Vittal [48] pushed the idea further by suggesting the use of individual machine energy functions. By introducing frequency-dependent load, Bergen and Hill [49-50] have developed a sound foundation for the energy approach. Narasimhamurthi [51] has proposed a Liapunov function that would allow the inclusion of the reactive power flow equations into the model.

### *Dynamic security regions*

Transient stability refers to the stability of the post-fault system. Kaye and Wu [52] define a region in the pre-fault injection (power generation and load demand) space, called dynamic security region (Fig. 5), to be the set of injections for which the post-fault system will be transiently stable. A method is proposed to derive dynamic security regions.

### 3.4. Related Topics

A reduced order dynamic model of the external system is called a *dynamic equivalent*. It is observed in practice that certain machines tend to react as a group, called *coherent* group. The utilization of coherent groups for dynamic equivalents has been suggested by Podmore and Germond [53-54], Wu Narasimhamurthi, Tsai [55-57], Sastry and Variaya [58], Gallai and Thomas [59], DiCaprio [60] have conducted analytic studies on coherency and suggested alternative algorithms. A more general decomposition and aggregation approach based on the concept of coherency was proposed by Kokotovic, Avramovic, Chow and Winkelman [61-65].

## 4. SECURITY

### 4.1. Deterministic Steady-State Security Assessment

The concept of power system security was introduced by Dy Liacco [66-68]. Security is considered to be an instantaneous time-varying condition that is a function of the robustness of the system relative to imminent disturbances [69]. A working definition of security introduced by Dy Liacco employs a deterministic framework in which the robustness of the system is tested, using the steady-state model, with respect to a set of selected disturbances, or contingencies. A system is said to be *secure* if it is in a normal operating state and none of the next contingency would cause a transition to an emergency state.

The major components of security assessment software for real-time power control center application include *state estimation*, *contingency selection*, *external network modeling* and *contingency evaluation* (Fig. 6). Missing and erroneous data occur frequently in the real-time environment. State estimation uses weighted least square method to estimate the state variables of the power system based on the telemetered data. A list of contingencies is selected, which should, in the ideal case, be based on their likelihood of occurrence and the consequence they would entail. The contingency evaluation uses a on-line power flow to assess the effect of contingencies. In doing so, a model of the external system which is not monitored is needed. More detail description on the state-of-the-art of these topics can be found in the review papers by Dy Liacco [67-68], or Talukdar and Wu [70]. Most modern power system control centers are equipped with some sort of steady-state security assessment capability.



#### 4.2. Probabilistic Dynamic Security Assessment

As we have stated in Sec. 1.4, there are two aspects of system failure events that should be considered in security assessment, namely, load curtailment and system collapse. The steady-state security assessment addresses primarily to the question of the adequacy of generating and transmission capacity to meet load demand. To address the question of the avoidance of uncontrolled cascading trippouts that lead to system collapse, dynamic response of the system following a disturbance should be considered. Furthermore, because of uncertainty inherent in the prediction of "imminent disturbances," a probabilistic framework for security assessment is more appropriate. Thus there is a need to extend the deterministic steady-state security assessment to *probabilistic dynamic* security assessment.

Because of heavy computational burden, on-line stability simulation does not seem viable. Recent research in the development of tools for on-line dynamic security assessment proposed by Ribbens-Pavella et. al. [71], and Fouad et. al. [72], is largely focused on the approach of the direct method.

Wu and Tsai [73,74] have developed a comprehensive framework for power system security assessment which incorporates probabilistic aspects of disturbances and system dynamic responses to disturbances. Standard mathematical models for power flow analysis and transient stability analysis are used. A linear vector differential equation is derived whose solution gives the probability distribution of the time to insecurity. The coefficients of the differential equation contain the transition rates of system structural changes and a set of transition probabilities defined in terms of the steady-state and the dynamic security regions, defined in the space of power injections (Sec. 2.3 and 3.3).

#### 4.3. Security Control

The traditional approach to secure control, or security enhancement, is again based on the list of next contingency [75]. The objective is to schedule generation so that the system will operate with the operating constraints satisfied for all contingencies. Linear programming has been used as a tool for the security rescheduling, see Stott et. al. [76-77]. A nonlinear programming approach to security assessment incorporating transient energy considerations is proposed by Chandrashekar and Hill [78].

Kaye and Wu [79] have proposed a security control scheme based on the framework of probabilistic steady-state and dynamic security assessment. Concepts and techniques from stochastic optimal control are utilized.

## **5. RELIABILITY**

### **5.1. Generation System Reliability**

In the classical generation system reliability evaluation, it is assumed that the transmission system is capable of carrying power flows from generation sources to load points within an area whenever needed. Therefore, the constraint on power balance, namely, the power flow equations, is replaced simply by the requirement that the available total system generation capacity is greater than the load demand. Because of possible failure (called forced outages) of the generators, the available total system generation capacity is a random variable, whose probability distribution function can be computed by the convolution formula using the probability of failure for each unit. The probability that there is inadequate generation capacity to meet the load demand is called the loss-of-load probability (LOLP), and the method is commonly used in industry [80,81].

Quite often system planners are interested in assessing the benefits of interconnection among areas. An area refers to a utility company or a

geographic region within a utility. The power transfer between two areas is limited by the capacities of the tie lines that connect the areas. The objectives of reliability studies of such multi-area power systems are to evaluate the enhancement of reliability due to interconnection and to identify interconnections whose improvement is most effective in increasing the system reliability. The multi-area interconnected power system can be modeled as a capacitated network with probabilistic arc capacities. Clancy, Gross and Wu [82] have developed a solution method for the evaluation of the reliability of such networks for power systems. The method uses the state space decomposition scheme for probabilistic flow networks proposed by Doulliez and Jamouille [83].

## 5.2. Bulk System Steady-State Reliability

Historically utilities have evaluated bulk system reliability based on a large number of power flow analysis and stability studies. Only recently have attempts been made to apply quantitative or probabilistic approaches to bulk system steady-state reliability. Several different approaches have been proposed [84].

The Monte Carlo approach has been popular in Italy and France [85,86]. Instead of relying on random number generators to draw cases, as in the Monte Carlo approach, an enumeration method using a list of contingencies has been proposed. It is called *contingency enumeration method*. The basic idea of the method is to add the probabilistic element to the approach described in Sec. 4.1 for steady-state security assessment. It employs a contingency selection subroutine to generate a set of sample points (cases) for reliability calculation. The probabilities and frequencies of failure cases are then added up. Marks, Mikolinnas et. al. [87,88] have demonstrated the feasibility of contingency enumeration method for realistic systems.

Alternative approaches have been proposed [89-91]. Moslehi and Wu [92-93] have suggested a set decomposition method for bulk system reliability evaluation without solving a power flow, even though the dc load flow model is incorporated in the formulation.

### 5.3. Bulk System Dynamic Reliability

Again the bulk system steady-state reliability addresses only to the question of adequacy of generation and transmission capacity to meet load demand. The bulk system dynamic reliability addresses to the question of the avoidance of instability leading to system collapse. Traditionally, a large number of stability runs are studied for that purpose. The inadequacy of such an approach and the importance of considering probabilistic aspects of the disturbances and the system response (particularly the response of the protective system) are pointed out by Billinton and Kuruganty [94]. Anderson et. al. [95-96] have attempted to apply Monte Carlo approach, coupled with the direct method, for a probabilistic approach to dynamic reliability evaluation. Tsai and Wu [97] have extended their probabilistic dynamic security assessment approach to the dynamic reliability evaluation problem. The resulting mathematical model is a nonstationary continuous-time Markov chain. Formulas for the limiting average frequency, duration, and probability of system failure are derived.

### 5.4. Reliability Planning

Normally in system planning different plans are studied, results of reliability evaluation are compared. Fischl et. al. [98] have suggested an automated transmission system planning method in which the dc load flow model is used and reliability constraints are incorporated.

## 6. CONCLUSION

The ability of a power system to supply load demand while the operating constraints are all satisfied is called reliability in the planning context and security in the operating context. This paper reviews the state of the art and current research in the analysis of reliability and security of bulk power systems. The reliability evaluation and secure operation of distribution systems are not considered in this paper.

There are two other aspects of power system planning and operation which are also related to reliability and security of power systems, but are not considered in this paper. One concerns with the situation when a system is capable of meeting the load demand. In such cases, the focus is then shifted to economics. Economic operation of a power system involves many topics, in addition to the optimal power flow (economic dispatch) that are mentioned in Sec. 2.4, there are unit commitment [99,100], hydro scheduling [100,101], etc.\* The other situation is when a system is incapable of supplying the demand without violating operating constraints. This is the time when emergency actions are called for. Zaborzsky et. al. [102-104] have developed a theory for emergency control.

The basic steps in the conventional approach to the analysis of bulk system reliability and security consist of the following:

- 1) Select a list of contingencies
- 2) Simulate system response for each contingency
- 3) Analyze the result by engineering judgement

Usually worst case scenarios are studied in the conventional approach. Concordia [105] has suggested that there is a certain arbitrariness in the contingency selection. Dandeno [106] has pointed out that based on statistical data the standard criteria for fault selection are too severe. On the other

---

\*The references cited in this section are the ones which reflect the most recent developments in that particular subject, they are not necessarily the representative references.

hand, the results from the analysis of major disturbances indicate that it is nearly impossible to predict in advance all the events which could trigger a major disturbance [107]. What is needed here, we believe, is a balanced approach to reliability and security analysis that takes into account the probability and frequency of contingency occurrence and severity of consequence. This can be achieved only through a probabilistic approach. Furthermore, the recent economic and regulatory constraints are corroding the enormous redundancy previously built in the system. Walraven [108] has remarked that the severity of future system problems may dictate that the system be planned to allow pre-arranged failure events (load interruption, islanding) to occur. In such an environment, the conventional analysis methods would be inadequate, whereas probability methodology could provide a more objective and consistent means for comparing different system designs.

The numerical simulation approach for the analysis of reliability and security of power systems has its inherent limitations. For large systems with a great number of cases to study, new approaches based on analytic understanding of the problem are needed. The review in this paper of current research in the analytic aspects of power system models has shown that in the last few years great progress has been made. As a matter of fact, most theoretical breakthroughs occurred within the last three to five years. However it has also been pointed out in the paper that the models used in the analytic studies so far are still too simplistic and some proposed methods in their embryonic form impose heavy computational burden. We believe that much more research is needed before we can enjoy the fruit of today's planting.

#### ACKNOWLEDGEMENT

The research is sponsored by the Department of Energy, Division of Electric Energy Systems, under contract DE-AC01-82-CE76221.

## REFERENCES

- [1] W. F. Tinney, C. E. Hart, "Power flow solution by Newton's method," *IEEE Trans. Power App. Syst.*, Vol. PAS-86, pp. 1449-1460, November 1987.
- [2] B. Stott, O. Alsac, "Fast decoupled load flow," *IEEE Trans. Power App. Syst.*, Vol. PAS-93, pp. 859-869, May 1974.
- [3] B. Stott, "Review of load flow calculation methods," *Proc. IEEE*, Vol. 62, pp. 916-929, July 1974.
- [4] F. F. Wu, "Theoretical study of the convergence of the fast decoupled load flow," *IEEE Trans. Power App. Syst.*, Vol. PAS-98, No. 1, pp. 268-275, January 1977.
- [5] J. Meisel, R. D. Barnard, "Application of fixed point techniques to load-flow studies," *IEEE Trans. Power App. Syst.*, Vol. PAS-89, pp. 136-140, January 1970.
- [6] J. Fong, and C. Pottle, "Parallel processing of power system analysis problems via simple parallel microcomputer structure," *IEEE Trans. Power App. Syst.*, Vol. PAS-97, pp. 1834-1841, September 1978.
- [7] R. Pritchard and C. Pottle, "High-speed power flows using attached scientific (array) processors," *IEEE Trans. Power App. Syst.*, Vol. PAS-101, pp. 249-253, January 1982.
- [8] F. D. Galiana, "Analytic properties of the load flow problem," *Proc. 1977 Int. Symp. Circuits and Systems*, Special Session on Power Systems, IEEE Catalog No. 77CH1188-2 CAS, pp. 802-816.
- [9] F. D. Galiana, "Analytical investigation of the power flow equations," *Proc. 1983 American Control Conference*, San Francisco, pp. 411-415, June 1983.

- [10] B. K. Johnson, "Extraneous and false load flow solutions," *IEEE Trans. Power App. Syst.*, Vol. PAS-96, pp. 524-534, March/April 1977.
- [11] A. Klos and A. Kerner, "Non-uniqueness of load flow solution," *Proc. PSCC V*, 3.1/8, Cambridge, July 1975.
- [12] Y. Tamura, Y. Nakanishi and S. Iwamoto, "On the multiple solution structure, singular point and existence condition of the multiple load flow solutions," *IEEE PES Winter Meeting*, A 80 044-8, New York, February 1980.
- [13] A. J. Korsak, "On the question of uniqueness of stable load flow solutions," *IEEE Trans. Power App. Syst.*, Vol. PAS-91, pp. 1093-1100, May/June 1972.
- [14] C. J. Tavora and O. J. M. Smith, "Equilibrium analysis of power systems," *IEEE Trans. Power App. Syst.*, Vol. PAS-91, pp. 1131-1137, May/June 1972.
- [15] A. Arapostathis, S. S. Sastry and P. Varaiya, "Analysis of power-flow equation," *Electrical Power and Energy Systems*, Vol. 3, pp. 115-126, July 1981.
- [16] A. Arapostathis and P. Varaiya, "Behavior of three-node power networks," *Electrical Power and Energy Systems*, Vol. 5, pp. 22-30, January 1983.
- [17] A. Arapostathis, S. S. Sastry and P. Varaiya, "Global analysis of swing dynamics," *IEEE Trans. Circuits and Systems*, Vol. CAS-29, pp. 673-678, October 1982.
- [18] J. Baillieul and C. I. Byrnes, "Geometrical critical point analysis of lossless power systems models," *IEEE Trans. Circuits and Systems*, Vol. CAS-29, pp. 724-737, November 1982.
- [19] J. Baillieul and C. I. Byrnes, "The load flow equations for a three-node electrical power system," *Systems and Control Letters*, Vol. 2, pp. 321-329, April 1983.



- [20] J. Baillieul and C. I. Byrnes, "The singularity theory of the load flow equations for a three-node electrical power system," *Systems and Control Letters*, Vol. 2, pp. 330-340, April 1983.
- [21] F. F. Wu and S. Kumagai, "Steady-state security regions of power systems," *IEEE Trans. Circuits and Systems*, Vol. CAS-29, pp. 703-711, November 1982.
- [22] R. Fischl, G. C. Ejebe, and J. A. DeMaio, "Identification of power system steady-state security regions under load uncertainty," Paper A76 495-2, IEEE Summer Power Meeting, July 1978.
- [23] E. Hnyilicza, S. T. Lee and F. C. Schweppe, "Steady-state security regions: Set-theoretic approach," in *Proc. 1975 PICA Conf.*, pp. 347-355.
- [24] P. Dersin and A. H. Levis, "Feasibility sets of steady-state loads in electric power networks," *IEEE Trans. Power App. Syst.*, Vol. PAS-101, pp. 60-70, January, 1982.
- [25] R. J. Kaye and F. F. Wu, "Analysis of linearized decoupled power flow approximations for steady-state security assessment," *IEEE Trans. Circuits and Systems*, to appear.
- [26] F. F. Wu and A. Monticelli, "A critical review on external network modeling for on-line security analysis," *Electrical Power and Energy Systems*, Vol. 5, October 1983.
- [27] H. H. Happ, "Optimal power dispatch -- a comprehensive survey," *IEEE Trans. Power App. Syst.*, Vol. PAS-96, No. 3, pp. 841-854, May/June 1977.
- [28] J. Carpentier, "Optimal power flows," *Electrical Power and Energy Systems*, Vol. 1, No. 1, April 1979.
- [29] B. Stott, O. Alsac and J. L. Marinho, "The optimal power flow," presented at the EPRI/SIAM International Conference on Electric Power Problems and

- the Mathematical Challenge, Seattle, Washington, March 18-20, 1980.
- [30] F. F. Wu, G. Gross, J. F. Luini, and P. M. Look, "A two-stage approach to solving large-scale optimal power flows," *Proc. 11th PICA Conference*, Cleveland, pp. 126-136, May 1979.
- [31] P. M. Anderson and A. Fouad, *Power System Stability and Control*, Iowa State University Press, 1977.
- [32] E. V. Larsen and W. W. Price, "MANSTAB/POSSIM power system dynamic analysis program -- A new combining nonlinear simulation and linearized state-space/frequency domain capabilities," *Proc. PICA*, pp. 350-358, May 1977.
- [33] G. Gross, C. F. Imparato and P. M. Look, "A tool for the comprehensive analysis of power system dynamic stability," *IEEE Trans. Power App. Syst.*, Vol. PAS-101, pp. 226-234, January 1982.
- [34] B. Stott, "Power system dynamic response calculations," *Proc. of the IEEE*, Vol. 67, pp. 219-241, February 1979.
- [35] M. H. Dwarakanath, B. Dembert, A. M. Erisman, K. Hemmaplardh, and J. W. Manke, "A generalized methodology for modeling system components in power system dynamics simulation," *IEEE Trans. Power App. Syst.*, Vol. PAS-101, pp. 136-146, January 1982.
- [36] W. L. Hatcher, F. M. Brasch, Jr., and J. E. Van Ness, "A feasibility study for the solution of transient stability problem by multiprocessor structures," *IEEE Trans. Power App. Syst.*, Vol. PAS-96, pp. 1789-1797, November/December 1977.
- [37] F. M. Brasch, Jr., J. E. Van Ness and S. C. Kang, "The use of a multiprocessor network for the transient stability problem," *Proc. 11th Power Industry Computer Application Conference*, Cleveland, pp. 337-344, May 1979.

- [38] S. Sastry and P. Varaiya, "Hierarchical stability and alert state steering control of power systems," *IEEE Trans. Circuits and Systems*, Vol. CAS-27, pp. 1102-1112, November 1980.
- [39] F. F. Wu and C-C. Liu, "Characterization of power system small disturbance stability with models incorporating voltage variation," submitted to *IEEE Trans. Circuits and Systems*.
- [40] E. Abed and P. Varaiya, "Nonlinear oscillations in power systems," Tech. Memo. UCB/ERL M83/4, Electronics Research Laboratory, University of California, Berkeley, January 1983.
- [41] E. Abed, N. Tsolas, and P. Varaiya, "Study of nonlinear oscillations due to exciter control," *Proc. 1983 American Control Conference*, San Francisco, pp. 674-678, June 1983.
- [42] N. Kopell and R. B. Washburn, Jr., "Chaotic motions in two-degree-of-freedom swing equations," *IEEE Trans. Circuits and Systems*, Vol. CAS-29, pp. 738-746, November 1982.
- [43] F. M. Abdel Salam, J. E. Marsden, and P. Varaiya, "Arnold diffusion in the swing equations of a power system," *IEEE Trans. Circuits and Systems*, to appear.
- [44] A. A. Fouad, "Stability theory-criteria for transient stability," in *Proc. Conference on System Engineering for Power: Status and Prospects*, Heniker, New Hampshire, 1975.
- [45] M. A. Pai, *Power System Stability Analysis by Direct Method of Lyapunov*, Amsterdam and New York: North Holland, 1981.
- [46] M. Ribbens-Pavela and F. J. Evans, "Direct methods in the study of the dynamics of large-scale electric power systems: a survey," in *Proc. 8th World IFAC Congress*, Vol: XX10-XX17, (Kyoto, Japan) August 1981.

- [47] T. Athay, R. Podmore and S. Virmani, "A practical method for the direct analysis of transient stability," *IEEE Trans. Power App. Syst.*, Vol. PAS-98, pp. 573-580, March/April 1979.
- [48] A. N. Michel, A. A. Fouad, and V. Vittal, "Power system transient stability using individual machine energy functions," *IEEE Trans. Circuits and Systems*, Vol. CAS-30, pp. 266-276, May 1983.
- [49] A. R. Bergen and D. J. Hill, "A structure preserving model for power systems stability analysis," *IEEE Trans. Power App. Syst.*, Vol. PAS-100, pp. 25-35, January 1981.
- [50] D. J. Hill and A. R. Bergen, "Stability analysis of multimachine power networks with linear frequency dependent loads," *IEEE Trans. Circuits and Systems*, Vol. CAS-29, pp. 840-848, December 1982.
- [51] N. Narasimhamurthi, and M. T. Musavi, "A general energy function for transient stability analysis of power systems," *IEEE Trans. Circuits and Systems*, to appear.
- [52] R. J. Kaye and F. F. Wu, "Dynamic security regions of power systems," *IEEE Trans. Circuits and Systems*, Vol. CAS-29, pp. 612-623, September 1982.
- [53] R. Podmore, "Identification of coherent generators for dynamic equivalents," *IEEE Trans. Power App. Syst.*, Vol. PAS-97, pp. 1344-1353, July 1978.
- [54] A. J. Germond and R. Podmore, "Dynamic aggregation of generating unit models," *IEEE Trans. Power App. Syst.*, Vol. PAS-97, pp. 1060-1069, July 1978.
- [55] F. F. Wu and N. Narasimhamurthi, "Coherency identification for power system dynamic equivalents," *IEEE Trans. Circuits and Systems*, Vol. CAS-30, pp. 140-147, March 1983.

- [56] F. F. Wu and Y-K. Tsai, "Identification of groups of  $\epsilon$ -coherent generators," *IEEE Trans. Circuits and Systems*, Vol. CAS-30, pp. 234-241, April 1983.
- [57] Y-K. Tsai, N. Narasimhamurthi, and F. F. Wu, "Structure-preserving model reduction with applications to power system dynamic equivalents," *IEEE Trans. Circuits and Systems*, Vol. CAS-29, pp. 525-535, August 1982.
- [58] S. Sastry and P. Varaiya, "Coherency for interconnected power systems," *IEEE Trans. Automat. Contr.*, Vol. AC-26, pp. 218-226, February 1981.
- [59] A. M. Gallai and R. J. Thomas, "Coherency identification and dynamic equivalents for large electric power system," *IEEE Trans. Circuits and Systems*, Vol. CAS-29, pp. 777-782, November 1982.
- [60] U. Di Caprio, "Conditions for theoretical coherency in multi-machine power systems," *Automatica*, Vol. 17, pp. 687-701, September 1981.
- [61] P. V. Kokotovic, B. Avramovic, J. H. Chow and J. R. Winkelman, "Coherency based decomposition and aggregation," *Automatica*, Vol. 18, pp. 47-56, 1982.
- [62] B. Avramovic, P. V. Kokotovic, J. R. Winkelman and J. H. Chow, "Area decomposition for electro-mechanical models of power systems," *Automatica*, Vol. 16, pp. 637-648, 1980.
- [63] J. R. Winkelman, J. H. Chow, J. J. Allemong, and P. B. Kokotovic, "Multi-time-scale analysis of a power system," *Automatica*, Vol. 16, pp. 35-43, 1980.
- [64] G. Peponides, P. V. Kokotovic, and J. H. Chow, "Singular perturbations and time scales in nonlinear models of power systems," *IEEE Trans. Circuits and Systems*, Vol. CAS-29, No. 11, 1982.

- [65] J. R. Winkelman, J. H. Chow, B. C. Bowler, B. Avramovic and P. V. Kokotovic, "An analysis of interarea dynamics of multi-machine systems," *IEEE Trans. Power App. Syst.*, Vol. PAS-100, pp. 754-763, 1981.
- [66] T. E. Dy Liacco, "The adaptive reliability control system," *IEEE Trans. Power App. Syst.*, Vol. PAS-86, pp. 517-531, May 1967.
- [67] T. E. Dy Liacco, "Real-time computer control of power systems," *Proc. of the IEEE*, Vol. 62, pp. 884-891, July 1974.
- [68] T. E. Dy Liacco, "System security: the computer's role," *IEEE Spectrum*, Vol. 15, pp. 43-50, June 1978.
- [69] L. H. Fink and K. Carlsen, "Operating under stress and strain," *IEEE Spectrum*, Vol. 15, pp. 48-53, March 1978.
- [70] S. N. Talukdar and F. F. Wu, "Computer-aided dispatch for electric power systems," *Proc. of the IEEE*, Vol. 69, pp. 1212-1231, October 1981.
- [71] M. Ribbens-Pavella, P. G. Murthy, J. L. Howard, and J. L. Carpentier, "Transient stability index for online stability assessment and contingency evaluation," *Electrical Power and Energy Systems*, Vol. 4, April 1982.
- [72] A. A. Fouad, S. E. Stanton, K. R. C. Mamandur, and K. C. Kruempel, "Contingency analysis using the transient energy margin technique," *IEEE Trans. Power App. Syst.*, Vol. PAS-101, pp 757-766, April 1982.
- [73] F. F. Wu and Y-K. Tsai, "Probabilistic dynamic security assessment of power systems: Part I - basic model," *IEEE Trans. Circuits and Systems*, Vol. CAS-30, pp. 148-159, March 1983.
- [74] F. F. Wu, Y-K. Tsai, and Y-X. Yu, "Probabilistic steady-state and dynamic security assessment," *IEEE Trans. Power App. Syst.*, to appear.
- [75] L. P. Hajdu, R. Podmore, "Security enhancement for power systems," *Proc. Engineering Foundations Conf. on Systems Engineering for Power*, New

England College, Henniker, New Hampshire, August 17-22, 1975.

- [76] B. Stott and E. Hobson, "Power system security control calculations using linear programming, Parts I & II," *IEEE Trans. Power App. Syst.*, Vol. PAS-97, pp. 1713-1731, September/October 1978.
- [77] B. Stott, J. L. Marinho and O. Alsac, "Review of linear programming applied to power system rescheduling," *Proc. PICA Conference*, Cleveland, pp. 142-154, May 1979.
- [78] K. S. Chandrashekhar and D. J. Hill, "Dynamic security dispatch: basic formulation," *IEEE Trans. Power App. Syst.*, Vol. PAS-102, pp. 2145-2154, July 1983.
- [79] R. J. Kaye and F. F. Wu, "Generation scheduling to maximize time to insecurity -- a stochastic optimal control approach," *Proc. 1983 American Control Conference*, San Francisco, pp. 679-684, June 1983.
- [80] R. Billington, *Power System Reliability Evaluation*, New York: Gordon & Breach, 1970.
- [81] J. Endrenji, *Reliability Modeling in Electric Power Systems*, New York: Wiley, 1978.
- [82] D. P. Clancy, G. Gross and F. F. Wu, "Probabilistic flows for reliability evaluation of multi-area power system interconnection," *Electrical Power and Energy Systems*, Vol. 5, pp. 101-114, April 1983.
- [83] P. Doulliez and E. Jamouille, "Transportation networks with random arc capacities," *Revue Francaise d'Automatique, Informatique et Recherche Operationelle*, Vol. 3, pp. 45-60, 1972.
- [84] IEEE Committee Report, "Bulk power system reliability assessment -- why and how?," *IEEE Trans. Power App. Syst.*, Vol. PAS-101, pp. 3439-3456, September 1982.

- [85] P. L. Noferi and L. Paris, "Quantitative evaluation of power system reliability in planning studies," *IEEE Trans. Power App. Syst.*, Vol. 91 pp. 611-618, 1972.
- [86] J. C. Dodu and A. Merlin, "An application of linear programming to the planning of large-scale power transmission systems: the Mexico program," *Proc. PSCC Cambridge*, 1975.
- [87] G. E. Marks, "A method of combining high-speed contingency load flow analysis with stochastic probability methods to calculate a quantitative measure of overall power system reliability," IEEE PES Winter Meeting, New York, Paper A78 228-9, February 1978.
- [88] T. A. Mikolinnas, W. R. Puntel, and R. J. Ringlee, "Application of adequacy assessment techniques for bulk power systems," *IEEE Trans. Power App. Syst.*, Vol. PAS-101, pp. 1219-1228, May 1982.
- [89] H. K. Cheong, and T. S. Dillon, "Extensions to the bounded-set theoretical approach to reliability modeling and calculations for composite generation-transmission systems using a DC load-flow model," *Electrical Power and Energy Systems*, Vol. 2, pp. 169-180, 1980.
- [90] S. J. Ranade and R. K. Sullivan, "A reliability analysis technique for bulk system planning," *IEEE Trans. Power App. Syst.*, Vol. PAS-100, pp. 3658-3665, 1981.
- [91] C. Liu and F. F. Wu, "A generalized network flow model with application to power supply demand problems," *Networks*, Vol. 13, 1983.
- [92] K. Moslehi and F. F. Wu, "Direct method for evaluation of bulk power system reliability, Part 1: Theoretical foundation," *Electrical Power and Energy Systems*, Vol. 5, pp. 3-7, January 1983.



- [93] K. Moslehi and F. F. Wu, "Direct method for evaluation of bulk power system reliability, Part 2: Solution Algorithm," *Electrical Power and Energy Systems*, Vol. 5, pp. 8-16, January 1983.
- [94] R. Billinton and P. R. S. Kuruganty, "A probabilistic index for transient stability," *IEEE Trans. Power App. Syst.*, Vol. PAS-00, pp. 195-206, January/February 1980.
- [95] P. M. Anderson and A. Bose, "A probabilistic approach to power system stability analysis," *IEEE Trans. Power App. Syst.*, Vol. PAS-102, pp. 2430-2439, August 1983.
- [96] K. J. Timko, A. Bose and P. M. Anderson, "Monte Carlo simulation of power system stability," *Proc. PICA Conference*, Houston, pp. 123-129, May 1983.
- [97] Y. Tsai and F. F. Wu, "Reliability systems modeled as continuous-time Markov chains with periodic transition rates," Tech. Report M81/20, Electronics Research Laboratory, University of California, Berkeley, April 1981.
- [98] R. Fischl, A. Guvenis and T. F. Halpin, "Statistical power transmission network design," *IEEE Trans. Circuits and Systems*, Vol. CAS-29, pp. 679-687, October 1982.
- [99] G. S. Lauer, N. R. Sandell, D. P. Bertsekav, and T. A. Posbergh, "Solution of large-scale optimal unit commitment problems," *IEEE Trans. Power App. Syst.*, Vol. PAS-101, pp. 79-86, January 1982.
- [100] A. I. Cohen, et al., "A unified approach to operations scheduling under uncertainty," Systems Control, Inc., Draft Final Report, USDOE Contract No. DE-AC01-79ET29243, October 1982.
- [101] Y. Ikura and G. Gross, "Efficient large scale hydro systems scheduling with forced spill conditions," *IEEE Trans. Power App. Syst.*, to appear.

- [102] J. Zaborszky, K. V. Prasad and K. W. Whang, "Operation of the large interconnected power system by decision and control," *IEEE Trans. Power App. Syst.*, pp. 28-36, 1980.
- [103] J. Zaborszky, K. W. Whang and K. V. Prasad, "Stabilizing control in emergencies. Part I. Equilibrium point and state determination," *IEEE Trans. Power App. Syst.*, pp. 2374-2380, May 1981.
- [104] J. Zaborszky, K. V. Prasad and K. W. Whang, "Stabilizing control in emergencies. Part II. Control by local feedback," *IEEE Trans. Power App. Syst.*, pp. 2381-2389, May 1981.
- [105] C. Concordia, "Assessment of system performance and reliability," in *Symposium on Reliability Criteria for System Dynamic Performance*, IEEE Publication 77CH1221-1-PWR, pp. 29-31, 1977.
- [106] P. L. Dandeno, "Current stability concepts based on standard criteria," Paper prepared for the panel session on Probabilistic Considerations in System Dynamic Performance Evaluation, IEEE PES Winter Meeting, New York, February 1981.
- [107] D. R. Davison, D. N. Ewart, and L. K. Kirchmayer, "Long term dynamic response of power systems: an analysis of major disturbances," *IEEE Trans. Power App. Syst.*, Vol. PAS-94, pp. 819-826, May 1975.
- [108] R. G. Walraven, "Transmission system planning problems to be solved in the next few years," in *Power System Planning and Operations: Future Problems and Research Needs*, EPRI-ERDA Workshop, Henniker, New Hampshire, February 1977.

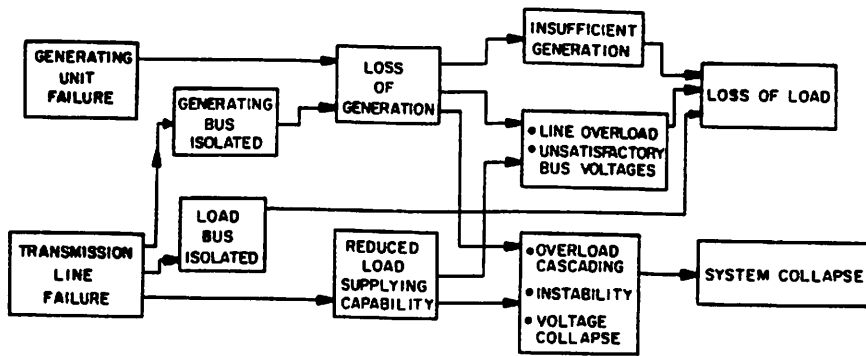

Fig. 1. System failure events.

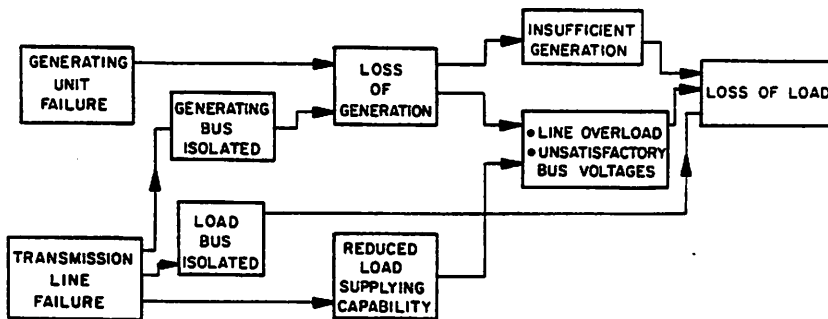

Fig. 2. System failure due to violation of steady-state constraints.

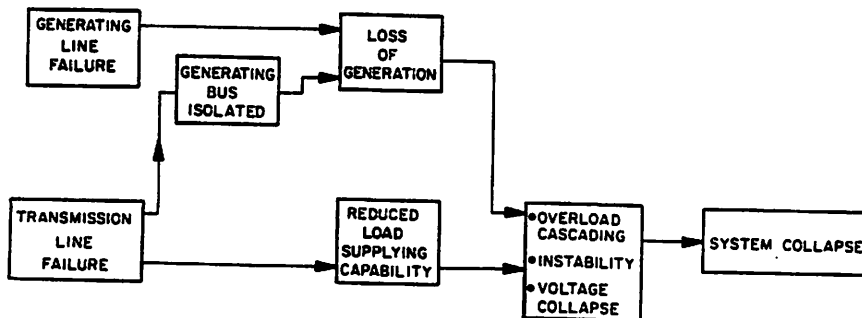

Fig. 3. System failure due to violation of dynamic constraints.

LOAD FLOW CONSTRAINTS

$$f_i(x) = y$$

SECURITY CONSTRAINTS

$$g_i(x) \leq 0$$

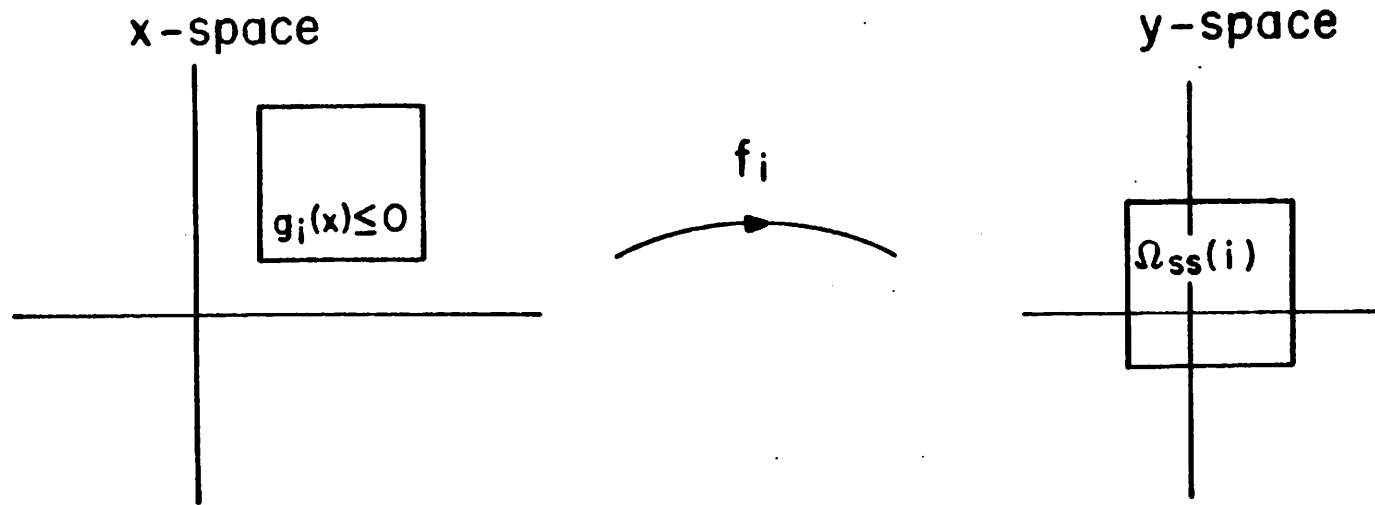

$$\Omega_{ss}(i) = \{ y \mid f_i(x) = y \ \& \ g_i(x) \leq 0 \}$$

Fig. 4. Steady-state security region  $\Omega_{ss}(i)$  for a given system configuration  $i$ .



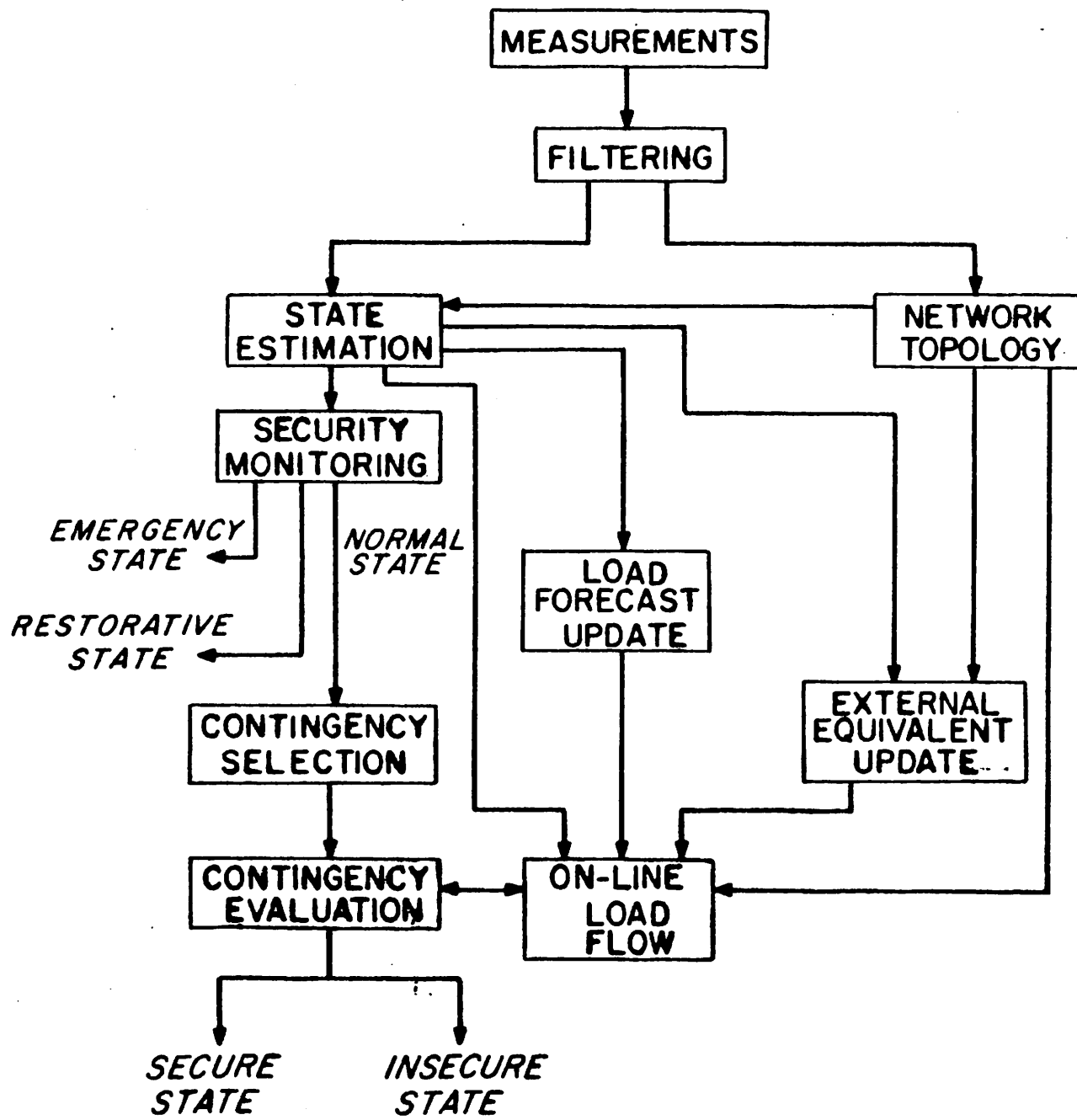

Fig. 6. The major components of deterministic steady-state security assessment.