

Copyright © 1997, by the author(s).
All rights reserved.

Permission to make digital or hard copies of all or part of this work for personal or classroom use is granted without fee provided that copies are not made or distributed for profit or commercial advantage and that copies bear this notice and the full citation on the first page. To copy otherwise, to republish, to post on servers or to redistribute to lists, requires prior specific permission.

**EXPERIMENTAL RESULTS OF STRANGE
NONCHAOTIC PHENOMENON IN A
SECOND-ORDER QUASI-PERIODICALLY
FORCED ELECTRONIC CIRCUIT**

by

Tao Yang and Kivanç Bilimgut

Memorandum No. UCB/ERL M97/43

13 June 1997

**EXPERIMENTAL RESULTS OF STRANGE
NONCHAOTIC PHENOMENON IN A
SECOND-ORDER QUASI-PERIODICALLY
FORCED ELECTRONIC CIRCUIT**

by

Tao Yang and Kivanç Bilimgut

Memorandum No. UCB/ERL M97/43

13 June 1997

ELECTRONICS RESEARCH LABORATORY

College of Engineering
University of California, Berkeley
94720

Experimental Results of Strange Nonchaotic Phenomenon in a Second-order Quasi-periodically Forced Electronic Circuit

Tao Yang and Kıvanç Bilimgüt

Electronics Research Laboratory and
Department of Electrical Engineering and Computer Sciences,
University of California at Berkeley,
Berkeley, CA 94720, U.S.A.

June 13, 1997

Abstract

In this paper, we study the strange nonchaotic attractor of a second-order quasi-periodically forced electronic circuit. This circuit, which is driven by two sinusoidal voltage sources, consists of a linear inductor, a linear capacitor, a linear resistor and a specifically designed piecewise-linear negative resistor. Both the experimental and the simulation results are provided to show the bifurcation process from two-frequency quasi-periodic attractors to strange nonchaotic attractors, and from strange nonchaotic attractors to strange chaotic attractors.

1 Introduction

The pioneering work in strange nonchaotic attractors was presented in [16]. Since then strange nonchaotic attractors have been found in forced pendulum[4, 36], quasi-periodically forced circle map[8], quasi-periodically von der Pol oscillator[22], quasi-periodically forced Ueda's circuit[26], quasi-periodically forced Chua's circuit[42], etc. A strange nonchaotic attractor has a fractal structure and contains an uncountable number of points and it is not piecewise differentiable. Since the typical trajectories on a strange nonchaotic attractor are not sensitive to the initial conditions, we call this kind of strange attractor "nonchaotic" (the word chaotic itself implies sensitivity to initial conditions). One significant characteristic of a strange nonchaotic attractor is that there exists no positive Lyapunov exponents. To summarize, a strange nonchaotic attractor is geometrically complicated but is not sensitive to initial conditions.

In most dynamical systems with period-doubling bifurcation to chaos, the strange nonchaotic attractors occur in a parameter set of measure zero. This means that we can not experimentally observe any strange nonchaotic attractors in this kind of systems. Fortunately, in dissipative dynamical systems which are driven by several incommensurate frequencies, i.e., quasi-periodic driven systems, there exist parameter regions with finite area in the parameter space for which there are

strange nonchaotic attractors[5, 4]. This is a very important property which enables us to observe and study the strange nonchaotic attractor in experiments.

An intuitive understanding of the existence of strange nonchaotic attractors can be achieved by thinking of the phase space as being divided into two subspaces where the trajectories are either purely expanded or purely contracted. Since the Lyapunov exponent is defined as the average expanding and contracting rate decided by the visiting frequency of the trajectories to both subspaces, a negative Lyapunov exponent means that the trajectories mostly visit the contracting subspace where a strange “nonchaotic” attractor happens. On the other hand, a positive Lyapunov exponent indicates that the trajectories mostly visit the expanding subspace where a strange “chaotic” attractor occurs.

Recently, lots of results of the strange nonchaotic phenomena were reported in many papers[10, 40, 28, 13, 1, 26, 15, 37, 2, 25, 14, 32, 24, 33, 31, 17, 39, 20, 19, 29, 41, 12, 7, 5, 18, 6, 3, 11, 22, 35, 9, 8, 36, 34, 21, 16, 4, 38, 42]. Although, there are lots of computer simulation results of strange nonchaotic attractors[4, 36, 8, 22, 26, 42], so far only one experimental observation was reported in a two-frequency quasi-periodically driven, buckled, magneto-elastic ribbon experiment[11]. The experimental configuration in [11] is of course complicated and expensive. In this paper, we present a *poor man’s* generator of strange nonchaotic attractor — a second-order electronic circuit, which consists of a linear inductor, a linear capacitor, a linear resistor and a specifically designed piecewise-linear negative resistor¹. When this electronic circuit was driven by a single sinusoidal voltage source, the strange chaotic attractor was observed by Nurall et al.[27]. When this electronic circuit was driven by two sinusoidal voltage sources, in addition to the existence of the strange chaotic attractor, also the existence of the strange nonchaotic attractor was verified by Kapitaniak and Chua[21] using simulation results. In [21], this circuit was driven by a single two-frequency signal. In this paper, we modified that configuration into a configuration that is driven by two independent periodic signals because the practical implementation of this experiment requires two independent signal generators to generate the driving signals. Since in our configuration, there are two independent voltage sources, we have one more parameter in our configuration than that presented in [21].

In a two-frequency quasi-periodical system, we can use the following characteristics to distinguish strange nonchaotic attractors from two-frequency quasi-periodical attractors and strange chaotic attractors.

- Fourier amplitude spectra

In a Fourier amplitude spectrum $|S(f)|$ we define a peak as a local maximum, and $N(\sigma)$ as the *spectral distribution function*, which is the number of peaks of $|S(f)|$ with amplitude greater than σ . It has been found that for a two-frequency quasi-periodical attractor and a strange nonchaotic attractor the relations between $N(\sigma)$ and σ are respectively $N(\sigma) \sim \ln(\sigma)$ and $N(\sigma) \sim \sigma^{-\alpha}$, $1 < \alpha < 2$ [36, 8, 11].

¹By using the off-shelf components, one can build one copy of this circuit with a cost less than 10 US dollars in USA and less than 1 US dollar in China.

- Lyapunov exponents

In the case of a two-frequency quasi-periodic system there are two Lyapunov exponents that are trivial in the sense that they are identically zero by virtue of the forcing frequencies. If we sort the Lyapunov exponents in a nondecreasing order as $\lambda_1 \leq \lambda_2 \leq \lambda_3 \leq \dots$, then for a two-frequency quasi-periodical attractor, a strange nonchaotic attractor, and a strange chaotic attractor, we respectively have: $\lambda_1 = \lambda_2 = 0 > \lambda_3$, $\lambda_1 = \lambda_2 = 0 > \lambda_3$, and $\lambda_1 > 0$. However, by using the standard method (as that provided in the standard software for nonlinear dynamical systems, e.g., INSITE[30]), we can not obtain reliable results for the nontrivial Lyapunov exponents (except for λ_1 in the chaotic cases), because all the calculated Lyapunov exponents would be negative. Thus, by using the Lyapunov exponents we can only conclude whether the system is chaotic or not.

- Winding number[22, 26, 36]

The winding number, W , for a second-order system is defined as the following limit

$$W = \lim_{t \rightarrow \infty} \{(\alpha(t) - \alpha(t_0))/t\} \quad (1)$$

where $(x_1, x_2) = (r \cos \alpha, r \sin \alpha)$. For the two-frequency quasi-periodic attractor, W satisfies

$$W = (l/n)\omega_1 + (m/n)\omega_2 \quad (2)$$

where l , m and n are integers. We can use the winding numbers to distinguish the two-frequency quasi-periodic attractor from the strange nonchaotic attractor[26].

2 Simulation Results of the Second-order Electronic Circuit Used in this Experiment

In this paper, we study the circuit in Fig.1. It is a modified version of the circuit presented in [27]. We let $S_1(t) = A_1 \sin(2\pi f_1 t + \phi_1)$ and $S_2(t) = A_2 \sin(2\pi f_2 t + \phi_2)$, where A_1 and A_2 are the amplitudes, f_1 and f_2 are the frequencies, and ϕ_1 and ϕ_2 are the phases, then the state equations of this circuit are given by

$$\begin{cases} \frac{dv_C}{dt} = \frac{1}{C}[i_L - f(v_C)] \\ \frac{di_L}{dt} = -\frac{1}{L}[-Ri_L - v_C + A_1 \sin(2\pi f_1 t + \phi_1) + A_2 \sin(2\pi f_2 t + \phi_2)] \end{cases} \quad (3)$$

where $f(\cdot)$ is the nonlinear characteristics of the piecewise linear negative resistor given by

$$f(v_1) = G_b v_1 + \frac{1}{2}(G_a - G_b)(|v_1 + E| - |v_1 - E|) \quad (4)$$

and E is the breakpoint voltage. This characteristic is depicted in Fig.1(b).

Before we build this circuit, simulations are used to determine the correct parameter values in

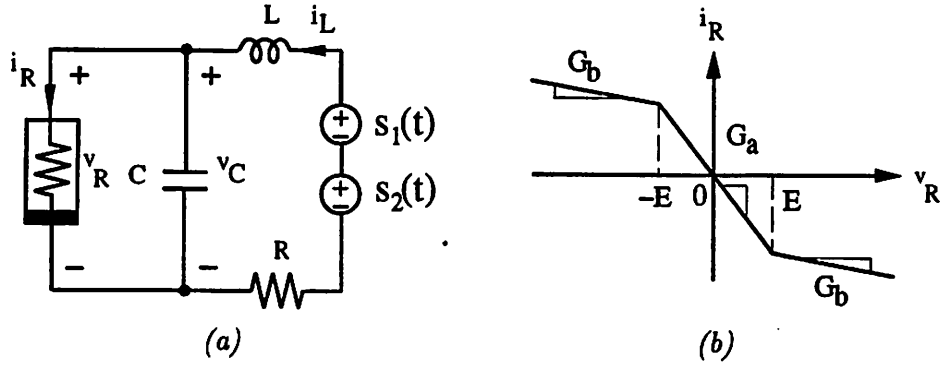

Figure 1: (a) The electronic circuit studied in this paper. (b) The characteristics of the piecewise linear negative resistor.

order to observe the strange nonchaotic attractor. In fact, our simulations are also based on the real circuit configurations. After some trial and error, we choose the fixed parameters as: $C = 10nF$, $L = 18mH$, $R = 1290\Omega$, $G_a = -0.76mS$, $G_b = -0.409mS$, $E = 1V$, $f_1 = 10204Hz$, and $f_2 = 2943Hz$. For simplicity, we also fixed $\phi_1 = \phi_2 = 0$. $A_2 = 0.1V$ is fixed and A_1 is the bifurcation parameter.

The evolution of the maximum Lyapunov exponent is shown in Fig.2. In Fig.2 we choose A_1 in the interval $[0,1]$ to show the largest Lyapunov exponent with respect to $A_2 = 0$.

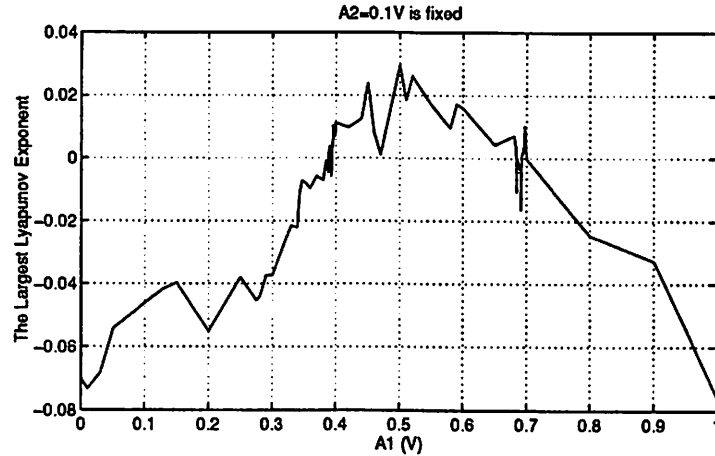

Figure 2: Evolving process of the largest Lyapunov exponent when A_1 as the bifurcation parameter.

We show the different attractors in simulations with different A_1 parameters in Fig.3. Figure 3(a) shows the attractor of $A_1 = 0.1V$ which is a quasi-periodic torus in surface of T^2 . Figure 3(b) shows the attractor of $A_1 = 0.35V$ which is a strange nonchaotic attractor. Figure 3(c) shows the attractor of $A_1 = 0.5V$ which is a chaotic attractor. Figure 3(d) shows the attractor of $A_1 = 0.75V$ which is a strange nonchaotic attractor. Figure 3(e) shows the attractor of $A_1 = 1V$ which is a quasi-periodic torus in the surface of T^2 . The classification of these simulation results are based on the largest Lyapunov exponent and the winding number.

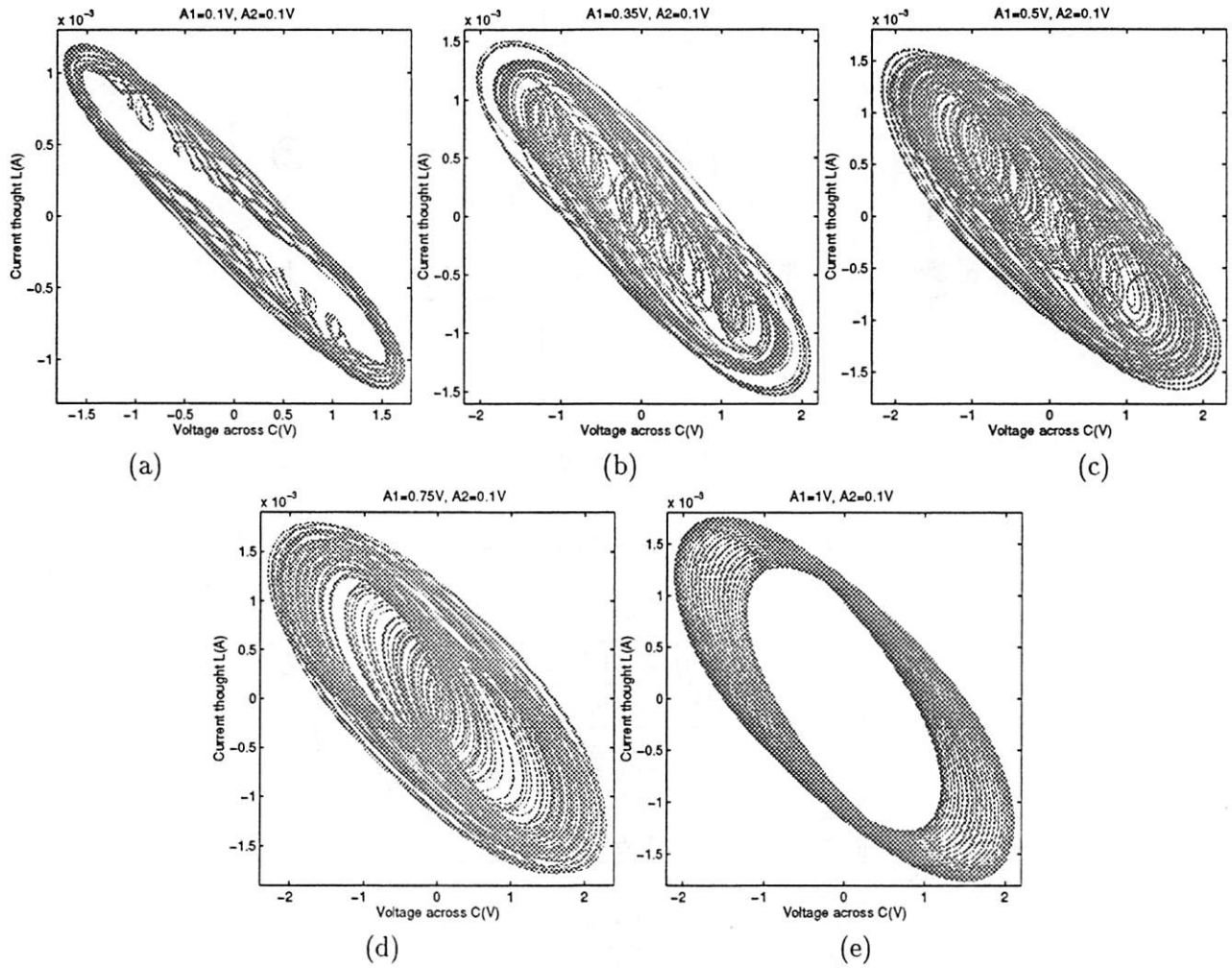

Figure 3: Different attractors for different A_1 's. $A_2 = 0.1V$ is fixed. (a) $A_1 = 0.1V$. (b) $A_1 = 0.35V$. (c) $A_1 = 0.5V$. (d) $A_1 = 0.75V$. (e) $A_1 = 1V$.

3 Experimental Results

The details of building the piecewise linear resistor $f(\cdot)$ can be found in [23]. The circuit configuration is shown in Fig.4. In this experiment, we show the bifurcation process when A_2 is fixed and A_1 is chosen as the bifurcation parameter. The parameters for this experiment are given in Table 1.

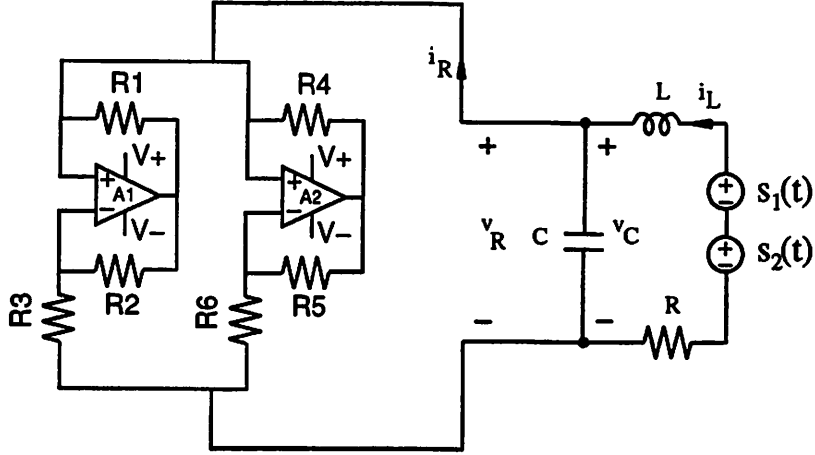
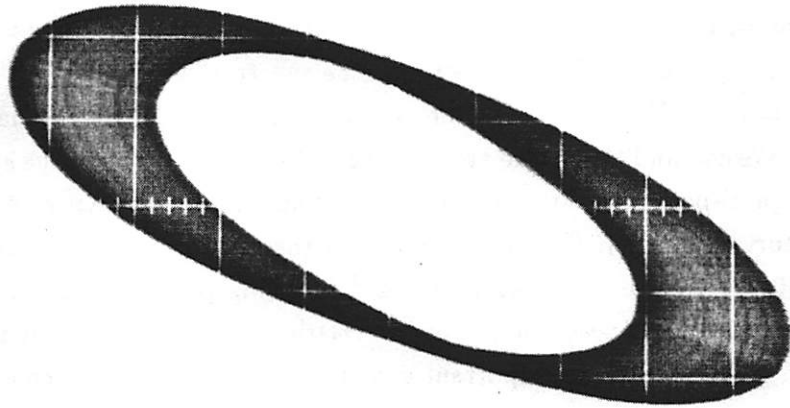

Figure 4: The configuration of the experimental circuit.

Table 1: Components used in the circuit.

	Device	value
A_1	Op amp $\frac{1}{2}$ AD712	
R_1	$\frac{1}{4}W$ resistor	220Ω
R_2	$\frac{1}{4}W$ resistor	220Ω
R_3	$\frac{1}{4}W$ resistor	$2.2k\Omega$
A_2	Op amp $\frac{1}{2}$ AD712	
R_4	$\frac{1}{4}W$ resistor	$22k\Omega$
R_5	$\frac{1}{4}W$ resistor	$22k\Omega$
R_6	$\frac{1}{4}W$ resistor	$3.3k\Omega$
C	capacitor	$10nF$
L	inductor	$18mH$
R	potentiometer($2k\Omega$)	1290Ω (tuned)

With the above component values, the parameter of the circuit is given by: $G_a = -0.76mS$, $G_b = -0.409mS$ and $E \simeq 1V$ (with $V_+ = +9V$ and $V_- = -9V$ as the power supplies to the two Op amps). The frequencies of $S_1(t)$ and $S_2(t)$ are fixed at $f_1 = 10204Hz$ and $f_2 = 2943Hz$. The experimental results are shown in Fig.5. In all the pictures in Fig. 5, the horizontal axis is the voltage across the capacitor (V_C) and is scaled to $0.5V/div$. Since we can not show the current through the inductor (i_L) directly in an oscilloscope, we use the vertical axis to represent the voltage across the resistor R (V_R) which has the relationship with i_L defined by $V_R = R \times i_L$. The vertical axis is scaled to $1V/div$.



(a)

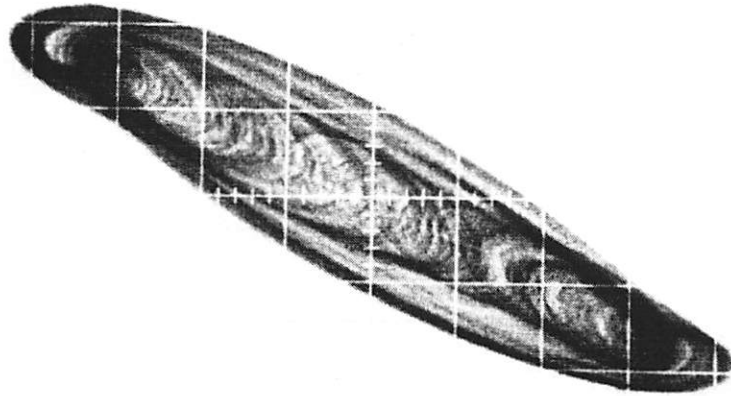

(b)

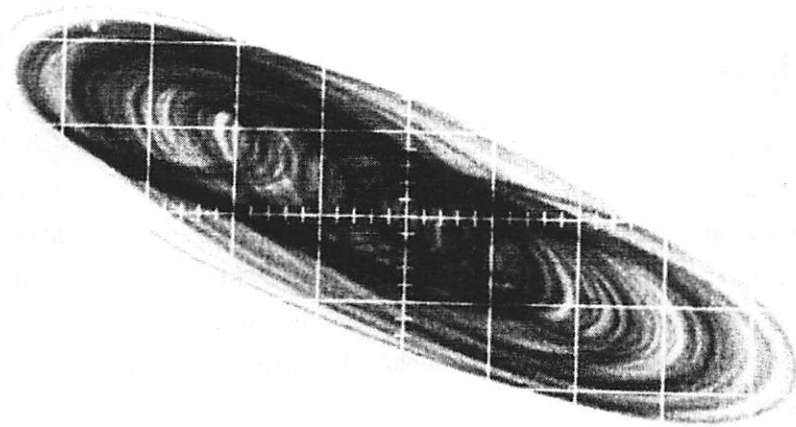

(c)

Figure 5: The experimental results with $A_2 = 0.1V$ fixed. (a) The two-frequency quasi-periodic attractor with $A_1 = 1V$. (b) The strange nonchaotic attractor with $A_1 = 0.35V$. (c) The strange chaotic attractor with $A_1 = 0.5V$.

We then verify the simulation results from the observed data. The spectral distributions for 3 different types of attractors are shown in Fig.6 with a fixed $A_2 = 0.1$. In Fig.6 the dashed curve, the dotted curve and the solid curve show respectively the spectral distributions of the cases of $A_1 = 1$, $A_1 = 0.5$ and $A_1 = 0.35$. We found that the results presented here are similar to those found in Ueda's circuit[26]. We can find that there are significant differences between the spectral distributions for two-frequency quasi-periodic attractor($A_1 = 1$), strange chaotic attractor($A_1 = 0.5$) and strange nonchaotic attractor($A_1 = 0.35$). The data we used is the voltage across the capacitor, $v_C(t)$. The sampling rate is $100KHz$ with 12-bit accurate. 2^{12} sampling points are used. The approximately straight solid line in Fig. 6 indicates the power-law relationship $N(\sigma) \sim \sigma^{-\alpha}$ with the best fit giving $2 > \alpha = 3.5/3 > 1$, which affords an important signature of the strange nonchaotic attractor.

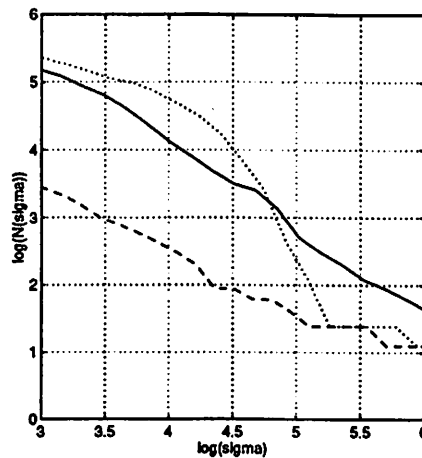

Figure 6: The spectrum distribution function of different types of attractors. $A_2 = 0.1$ is fixed. The results for $A_1 = 1$ (dashed curve), $A_1 = 0.5$ (dotted curve) and $A_1 = 0.35$ (solid curve) are shown.

4 Conclusions

In this paper, we studied the strange nonchaotic phenomenon in a second-order quasi-periodically forced electronic circuit. First, we used simulation results to show the bifurcation process of this circuit from two-frequency quasi-periodic attractors to strange nonchaotic attractors, and to strange chaotic attractors. Then, experimentally we observed the existence of the strange nonchaotic attractors as a part of the whole bifurcation process as predicted by the simulations. Furthermore, our experiments also verified that the strange nonchaotic attractors exist in sets of positive measure in the parameter space.

Biographies of Authors



Tao Yang was born in Wuhan, China, January 1, 1970. He received the B.E. and M.E. degrees both in Electrical Engineering from Tongji University, Shanghai, China, in 1990 and 1993 with honors, respectively. From 1993 to 1994, he was with the Department of Automatic Control Engineering, Shanghai University of Technology, Shanghai, China. Since 1995, he is a specialist in the Nonlinear Electronics Laboratory, Department of Electrical Engineering and Computer Sciences, University of California at Berkeley.

His research interests include automatic control, nonlinear dynamic systems, neural networks, fuzzy systems, general brain theory and supernatural phenomena.

He had published more than 40 technical papers in different international journals and different proceedings of international conferences. He serves as a reviewer for several technical journals including: *IEEE Transactions on Circuits and Systems*, *International Journal of Bifurcation and Chaos* and *SIAM Journal on Applied Mathematics*.

In 1993, jointed with Prof. L.B.Yang of E-Zhou University, Hubei, China, he invented the fuzzy cellular neural network. In 1995, jointed with Prof. L.O.Chua of University of California at Berkeley, USA, he solved the adaptive channel compensation problem in chaotic secure communication system. He was the inventor of chaotic cryptography based on continuous chaotic systems(1996). He was the first one to apply impulsive differential equations with the impulsive control and synchronization of chaotic systems(1996). He was the first one to apply impulsive synchronization of chaotic systems to chaotic digital code-division multiple access (CDMA) systems and to apply generalized synchronization to chaotic channel independent secure communication systems(1997).

He received the Overseas Professor Chair of E-Zhou University, China in 1997. He is a member of the IEEE. He is the founder and the director of E-Zhou Association of Supernatural Phenomena, China.



Kıvanç Bilimgüt was born in Ankara, Turkey, June 13, 1967, she received her B.A. in Cultural Studies from Hacettepe University, Ankara, Turkey in 1990 with honors. Soon after, she came to the United States to pursue a degree in Electrical Engineering and Computer Sciences. She is currently a graduating senior in the Department of Electrical Engineering and Computer Sciences, University of California at Berkeley. Her interests include communication systems, nonlinear dynamic systems, computer aided design, the impact of technology on society, and the use of technology to improve the life-standard of disabled people.

References

- [1] V.S. Aninschenko, T.E. Vadivasova, and O. Sosnovtseva. Strange nonchaotic attractors in autonomous and periodically driven systems. *Physical Review E (Statistical Physics, Plasmas, Fluids, and Related Interdisciplinary Topics)*, 54(no.4, pt.A):3231–4, Oct. 1996.
- [2] V.S. Anishchenko, T.E. Vadivasova, and O. Sosnovtseva. Mechanisms of ergodic torus destruction and appearance of strange nonchaotic attractors. *Physical Review E (Statistical Physics, Plasmas, Fluids, and Related Interdisciplinary Topics)*, 53(5, pt.A):4451–6, May 1996.
- [3] J. Awrejcewicz and W.-D. Reinhardt. Quasiperiodicity, strange non-chaotic and chaotic attractors in a forced two degrees-of-freedom system. *Zeitschrift fur Angewandte Mathematik und Physik*, 41(5):713–27, Sept. 1990.
- [4] A. Bondeson, E. Ott, and Jr Antonsen, T.M. Quasiperiodically forced damped pendula and schrödinger equations with quasiperiodic potentials: implications of their equivalence. *Physical Review Letters*, 55(20):2103–2106, 11 Nov. 1985.
- [5] J. Brindley and T. Kapitaniak. Analytic predictors for strange non-chaotic attractors. *Physics Letters A*, 155(6-7):361–4, 20 May 1991.
- [6] J. Brindley and T. Kapitaniak. Existence and characterization of strange nonchaotic attractors in nonlinear systems. *Chaos, Solitons and Fractals*, 1(4):323–37, 1991.
- [7] J. Brindley, T. Kapitaniak, and M.S. El Naschie. Analytical conditions for strange chaotic and nonchaotic attractors of the quasiperiodically forced van der pol equation. In *Nonlinear Science: The Next Decade. 10th Annual International Conference*, pages 28–38, Los Alamos, NM, USA, 21-25 May 1990. also in *Physica D*, Aug. 1991, vol. 51, no.1-3.
- [8] M. Ding, C. Grebogi, and E. Ott. Evolution of attractors in quasiperiodically forced systems: from quasiperiodic to strange nonchaotic to chaotic. *Physical Review A (General Physics)*, 39(5):2593–8, 1 March 1989.
- [9] Mingzhou Ding, C. Grebogi, and E. Ott. Dimensions of strange nonchaotic attractors. *Physics Letters A*, 137(4-5):167–72, 15 May 1989.
- [10] W.X. Ding, H. Deutsch, A. Dinklage, and C. Wilke. Observation of a strange nonchaotic attractor in a neon glow discharge. *Physical Review E (Statistical Physics, Plasmas, Fluids, and Related Interdisciplinary Topics)*, 55(no.3, pt.B):3769–72, March 1997.
- [11] W.L. Ditto, M.L. Spano, H.T. Savage, S.N. Rauseo, , et al. Experimental observation of a strange nonchaotic attractor. *Physical Review Letters*, 65(5):533–6, 30 July 1990.
- [12] M.S. El Naschie. Peano dynamics as a model for turbulence and strange nonchaotic behaviour. *Acta Physica Polonica A*, 80(1):3–13, July 1991.

- [13] S.S.E.H. Elnashaie and A. Ajbar. Chaotic, non-chaotic strange attractors and bistability in non-isothermal fluidized bed catalytic reactors under pi control. *Chaos, Solitons and Fractals*, 7(11):1955–67, Nov. 1996.
- [14] U. Feudel, J. Kurths, and A.S. Pikovsky. Strange non-chaotic attractor in a quasiperiodically forced circle map. *Physica D*, 88(3-4):176–86, 1 Dec. 1995.
- [15] U. Feudel, A. Pikovsky, and A. Politi. Renormalization of correlations and spectra of a strange nonchaotic attractor. *Journal of Physics A (Mathematical and General)*, 29(17):5297–311, 7 Sept. 1996.
- [16] C. Grebogi, E. Ott, S. Pelikn, and J.A. Yorke. Strange attractors that are not chaotic. *Physica D*, 13D(1-2):261–8, Aug. 1984.
- [17] J.F. Heagy and S.M. Hammel. The birth of strange nonchaotic attractors. *Physica D*, 70(1-2):140–53, 1 Jan. 1994.
- [18] T. Kapitaniak. On strange nonchaotic attractors and their dimensions. *Chaos, Solitons and Fractals*, 1(1):67–77, 1991.
- [19] T. Kapitaniak. Strange non-chaotic transients. *Journal of Sound and Vibration*, 158(1):189–94, 8 Oct. 1992.
- [20] T. Kapitaniak. Generating strange nonchaotic trajectories. *Physical Review E (Statistical Physics, Plasmas, Fluids, and Related Interdisciplinary Topics)*, 47(2):1408–10, Feb. 1993.
- [21] T. Kapitaniak and L.O. Chua. Strange nonchaotic trajectories on torus. *International Journal of Bifurcation and Chaos in Applied Sciences and Engineering*, 7:in press, 1997.
- [22] T. Kapitaniak, E. Ponce, and J. Wojewoda. Route to chaos via strange non-chaotic attractors. *Journal of Physics A (Mathematical and General)*, 23(8):L383–7, 21 April 1990.
- [23] M.P. Kennedy. Robust op amp realization of chua’s circuit. *Frequenz*, 46(3-4):66–80, 1992.
- [24] S.P. Kuznetsov, A.S. Pikovsky, and U. Feudel. Birth of a strange nonchaotic attractor: a renormalization group analysis. *Physical Review E (Statistical Physics, Plasmas, Fluids, and Related Interdisciplinary Topics)*, 51(3, pt.A):R1629–32, March 1995.
- [25] Ying-Cheng Lai. Transition from strange nonchaotic to strange chaotic attractors. *Physical Review E (Statistical Physics, Plasmas, Fluids, and Related Interdisciplinary Topics)*, 53(1, pt.A):57–65, Jan. 1996.
- [26] Zhong Liu and Zhiwen Zhu. Strange nonchaotic attractors from quasiperiodically forced ueda’s circuit. *International Journal of Bifurcation and Chaos in Applied Sciences and Engineering*, 6(7):1383–8, 1996.

- [27] K. Murali, M. Lakshmanan, and L.O. Chua. Bifurcations and chaos in the simplest dissipative non-autonomous circuit. *International Journal of Bifurcation and Chaos in Applied Sciences and Engineering*, 4(6):1151–1524, 1994.
- [28] T. Nishikawa and K. Kaneko. Fractalization of a torus as a strange nonchaotic attractor. *Physical Review E (Statistical Physics, Plasmas, Fluids, and Related Interdisciplinary Topics)*, 54(6):6114–24, Dec. 1996.
- [29] M. Pagitsas, A. Karantonis, and D. Sazou. Dynamical response of the quasiperiodically forced franck-fitzhugh model for the electrodisolution of iron in sulfuric acid solutions: observation of quasiperiodic, strange nonchaotic and chaotic behavior. *International Journal of Bifurcation and Chaos in Applied Sciences and Engineering*, 2(2):295–311, June 1992.
- [30] Thomas S. Parker and Leon O. Chua. *Practical numerical algorithms for chaotic systems*. Springer Verlag, New York, 1989.
- [31] A.S. Pikovsky and U. Feudel. Correlations and spectra of strange nonchaotic attractors. *Journal of Physics A (Mathematical and General)*, 27(15):5209–19, 7 Aug. 1994.
- [32] A.S. Pikovsky and U. Feudel. Characterizing strange nonchaotic attractors. *Chaos*, 5(1):253–60, March 1995.
- [33] S. Rajasekar. Conversion of a chaotic attractor into a strange nonchaotic attractor in a one dimensional map and bvp oscillator. *Pramana, Journal of Physics*, 44(2):121–31, Feb. 1995.
- [34] F.J. Romeiras, A. Bondeson, E. Ott, Jr. Antonsen, T.M., , et al. Quasiperiodically forced dynamical systems with strange nonchaotic attractors. *Physica D*, 26D(1-3):277–94, May-June 1987.
- [35] F.J. Romeiras, A. Bondeson, E. Ott, Jr. Antonsen, T.M., , et al. Quasiperiodic forcing and the observability of strange nonchaotic attractors. *Physica Scripta*, 40(3):442–4, Sept. 1989.
- [36] F.J. Romeiras and E. Ott. Strange nonchaotic attractors of the damped pendulum with quasiperiodic forcing. *Physical Review A (General Physics)*, 35(10):4404–13, 15 May 1987.
- [37] O. Sosnovtseva, U. Feudel, J. Kurths, and A. Pikovsky. Multiband strange nonchaotic attractors in quasiperiodically forced systems. *Physics Letters A*, 218(3-6):255–67, 5 Aug. 1996.
- [38] A. Venkatesan and M. Lakshmanan. Nonlinear dynamics of damped and driven velocity-dependent systems. *Phys. Rev. E.*, page (in press), 1997.
- [39] M.-Z. Wei and J.S. Dowker. Chaotic streamlines and a strange nonchaotic attractor in divergence-free flows on the 3-sphere. *Chaos, Solitons and Fractals*, 3(3):295–306, May-June 1993.

- [40] T. Yalcinkaya and Ying-Cheng Lai. Blowout bifurcation route to strange nonchaotic attractors. *Physical Review Letters*, 77(25):5039–42, 16 Dec. 1996.
- [41] Ting Zhou, F. Moss, and A. Bulsara. Observation of a strange nonchaotic attractor in a multistable potential. *Physical Review A (Statistical Physics, Plasmas, Fluids, and Related Interdisciplinary Topics)*, 45(8):5394–400, 15 April 1992.
- [42] Zhiwen Zhu and Zhong Liu. Strange nonchaotic attractors of chua’s circuit with quasiperiodic excitation. *International Journal of Bifurcation and Chaos in Applied Sciences and Engineering*, 7(1):227–238, 1997.