

History of the UC Berkeley Microlab

Katalin Voros



Electrical Engineering and Computer Sciences
University of California at Berkeley

Technical Report No. UCB/EECS-2013-158

<http://www.eecs.berkeley.edu/Pubs/TechRpts/2013/EECS-2013-158.html>

September 11, 2013

Copyright © 2013, by the author(s).
All rights reserved.

Permission to make digital or hard copies of all or part of this work for personal or classroom use is granted without fee provided that copies are not made or distributed for profit or commercial advantage and that copies bear this notice and the full citation on the first page. To copy otherwise, to republish, to post on servers or to redistribute to lists, requires prior specific permission.



History of the UC Berkeley Microlab 1983-2010 Closing Report

Katalin Voros
Operations Manager
(1987-2010)

Abstract

The UC Berkeley Microfabrication Laboratory (Microlab) in Cory Hall had its opening dedication ceremony on 23 March 1983. It was officially closed on 31 December 2010. This report is the documentation, in wide swathes, of 28 years of operation, including management of resources: facilities, staff, finances, and related activities of control, communications and planning.

Although the Microlab in Cory Hall ceased to exist, research operations continue in the new Marvell Nanofabrication Laboratory (NanoLab) in Sutardja Dai Hall, the second reincarnation of the original Integrated Circuits Laboratory of 1962. Thus, the tradition of cutting edge research based on micro/nano-electronic fabrication continues at Berkeley.

2013

Table of Contents

List of Figures	iv
List of Tables	viii
Glossary	ix
I. Introduction	1
II. History	2
III. Timeline	10
IV. Organization	15
V. Operations	20
Management of Resources	
1. Facilities	20
Laboratory Space	20
Satellite Labs	21
2. Utilities	23
Monitoring of Utilities	24
Utilities Dependencies Database	25
Campus Utilities	27
Other Factors – Neighborhood Construction Projects	28
3. Equipment	36
Equipment Access Control	39
Equipment and Utilities Maintenance	40
4. Machine Shop	47
5. Microlab Staff	49
Maintenance Staff	51
Process Staff	53
Baseline Engineering	56
Associated Researchers	62
Administration	63
Computer Support	64
Staff Development	66
6. Safety	70
VI. Finances	73
The Microlab’s User Base	73
Microlab as a Recharge Center	74
Record Keeping and Reports	77
Capital Equipment	78
Financial History of the Microlab	79
Industrial Members (BMLA)	81
Funding Laboratory Development	82
6” Upgrade	82
Move of the Microlab into the New NanoLab	84

VII.	Computer Information and Management System	85
	System Description	87
	Development and Upgrades	89
	New equipment control system, WIS	90
	The Common and Personal Environment, CAPE	90
	Microlab Gas Database	91
	Resource Utilization Management System, RUMS	91
	New Design – Mercury	94
	Database	95
	MercuryClient	96
	MercuryWeb	97
	New Equipment Interlock System – Hydra	98
	Parallel Operations and Synchronization	99
	Summary of the Microlab’s Computer System Development	100
VIII.	Planning, Development, and Communications	102
	Laboratory Development	102
	Start-up: 1983-1986	102
	Expansion into Satellite Labs: 1993-2004	103
	Six-Inch Upgrade: 1998-2004	104
	New Lab Development: 2004-2009	106
	Membership Development	107
	User Training – Lab Orientation	110
	Controls	111
	Lab Members’ Meetings	112
	Outreach – Summer Internship	112
	Departmental Activities	113
	EE143 Support	113
	Competitive Semiconductor Manufacturing Program	114
	Graduate Seminar	115
	Staff Activities	115
	Public Relations	117
	Labnetwork	120
	Microlab Events	121
	Closing of the Microlab	129
IX.	Summary	130
X.	References	133
XI.	Photo Gallery	137
	Acknowledgements	168
	Biography	171

Appendix: Year-End Reports by K. Voros, 1986-2012. Separate Technical Report at <http://www.eecs.berkeley.edu/Pubs/TechRpts/2013>.

List of Figures

- Fig. 1. M. Bujatti, D. McDaniel, and D. Hodges in the Integrated Circuits Lab (1963).
- Fig. 2. Prof. Oldham at an early epitaxial deposition system (1963).
- Fig. 3. Bipolar-JFET counting bistable circuit. D. Hodges, Prof. Pederson (1963).
- Fig. 4. Bipolar integrated circuit. G. Rigby, Prof. Pederson (1965).
- Fig. 5. Voltage controlled oscillator. W. Howard, Prof. Pederson (1967).
- Fig. 6. Drift offset compensated amplifier. G. L. Baldwin, Prof. Pederson (1969).
- Fig. 7. Low-distortion, wide-band variable-gain amplifier. W. Sansen, Prof. Meyer (1972).
- Fig. 8. Surface acoustic wave device (SAW). F. W. Voltmer, Prof. White (1965).
- Fig. 9. Piezoelectric field-effect transistor strain transducers. J. Conragan, Prof. Muller (1969).
- Fig. 10. Image contour extractor. P. Suciu, Prof. Hodges (1975).
- Fig. 11. PABX line-finder circuit. R. E. Suarez, Prof. Gray (1976).
- Fig. 12. Prof. Gray and student Jim McCreary at the rubylith table.
- Fig. 13. Camera for mask making.
- Fig. 14. Prof. Hodges and student W. Black at the new ion implanter, Extrion 300, called Iona (1973).
- Fig. 15. First CMOS and first ion-implanted circuit made in the lab. W. Black, R. McCharles, Prof. Hodges (1976).
- Fig. 16. NMOS third-order switched capacitor precision elliptic low-pass filter. D. J. Allstot, Prof. Gray (1977).
- Fig. 17. Microlab layout as designed (1981).
- Fig. 18. Modular lab walls (1982).
- Fig. 19. Front cover of the booklet prepared for the dedication of the new lab. Shown are the color-coded utility lines in the ceiling [6].
- Fig. 20. Arched hallway lends the laboratory a spacious feeling upon entry (1983).
- Fig. 21. Operational management: systems and controls.
- Fig. 22. Microlab layout in 1993.
- Fig. 23. Satellite labs of the Microlab in 2000.
- Fig. 24. Lobbying for a new air conditioning system. Visit of high-level staff from Campus Services, in 1993, with Johnny Torrez, Assistant Vice Chancellor for Campus Services in the middle.
- Fig. 25. Cory Hall from the corner of Hearst Avenue and Gayley Road (1987).
- Fig. 26. Soda Hall in February 1993.
- Fig. 27. Soda Hall, completed in 1994, on the corner of Hearst and Le Roy Avenues.
- Fig. 28. Microlab LN vessels (3000 and 9000 gallons) and specialty gases service area, wedged between Cory Hall and HMMB's mechanical service building.
- Fig. 29. Renovated Hearst Memorial Mining Building, with Cory Hall's signature arch showing.
- Fig. 30. Construction of CITRIS Headquarters, seen from 406 Cory Hall (2007). (Before the structure blocked the Bay view.)
- Fig. 31. Sub-fab construction of the laboratory wing of the CITRIS building (2006).

- Fig. 32. Microlab staff, soon to become Marvell NanoLab staff, watching from the roof of Cory Hall, the “Topping Out” ceremony of the CITRIS Headquarters building (March 2007).
- Fig. 33. Marvell NanoLab wing; the NW corner includes a clean stairwell between the two lab floors.
- Fig. 34. West facade of the NanoLab (with view of the Golden Gate bridge from the fifth floor window).
- Fig. 35. Partial view of the NanoLab wing and the main part of Sutardja Dai Hall (SDH), as seen from Hearst Avenue.
- Fig. 36. NanoLab as viewed from the plaza between Blum Hall and SDH.
- Fig. 37. North entrance to Sutardja Dai Hall from Hearst Avenue; Marvell NanoLab on left, CITRIS Headquarters in center, Blum Hall (formerly Naval Architecture) on right.
- Fig. 38. The A. Richard Newton Bridge between Cory Hall (left) and SDH (right), viewed from Hearst Avenue.
- Fig. 39. Equipment enable page of the WAND.
- Fig. 40. PROJECTS page on STAFF.
- Fig. 41. Detail of projects listings
- Fig. 42. Microlab and Machine Shop staff moving equipment during the 6” upgrade (2000).
- Fig. 43. Example page from the equipment problem reporting module, FAULTS.
- Fig. 44. Cory Hall Machine Shop Staff (2013).
- Fig. 45. Microlab staff list in 1985.
- Fig. 46. Microlab staff list in 1987.
- Fig. 47. Microlab organizational chart in 1992.
- Fig. 48. Pipelined A/D converter. L.C. Yiu, Prof. Gray, 1987.
- Fig. 49. Detail of Fig. 48, with UCB Microlab.
- Fig. 50. Pipelined 9-bit A/D converter. S. H. Lewis, Prof. Gray (1986).
- Fig. 51. Layout of composite chip fabricated in the Microlab. C.K. Wang, S. Sutardja, K.Y. Toh (1986).
- Fig. 52. CMOS 250 Mb/s cross-point switch. H. J. Shin, Prof. Hodges (1986).
- Fig. 53. Multifunctional sensor chip with CMOS ICs. D. Polla, K. Voros (1987).
- Fig. 54. Layout of composite chip from Baseline Report V [45].
- Fig. 55. Layout of composite chip from Baseline Report VII [49].
- Fig. 56. Interaction of Microlab support groups.
- Fig. 57. Microlab staff photo from 1990.
- Fig. 58. Microlab staff photo from 2006.
- Fig. 59. Microlab staff organizational chart in Jan 2010, just before moving to the new lab.
- Fig. 60. Banner above the entrance to the Microlab, calling attention to the Safety Fest Month (1993).
- Fig. 61. Safety Bunny leading good lab members to work safely.
- Fig. 62. Lab Manager K. Voros and student (now professor) Michel Maharbiz (2000).
- Fig. 63. Campus EH&S safety logo.
- Fig. 64. Microlab utilization expressed in use-hours of research groups, 1987-1992.
- Fig. 65. Laboratory and equipment use-hours, FYs 2005/06-2010/11, used for recharge rate calculations.
- Fig. 66. Microlab income vs. membership, 1986-2010.
- Fig. 67. Mortgage burning celebration, 20 August 1997.

- Fig. 68. Microlab income by research groups, 1994-2000.
- Fig. 69. Supplies & Expenses vs. Salaries & Benefits portions of the budget, 1998-2010.
- Fig. 70. Lab members' complaint. Present from Andrea Franke, 2000.
- Fig. 71. NanoLab ready for move-in.
- Fig. 72. W. Flounders discussing tool siting.
- Fig. 73. Microlab/Nanolab equipment use-time comparison during transfer, July 2009 to May 2011.
- Fig. 74. Microlab technician and graduate student (in the Taurus chase) discussing wiring configuration of the equipment control system. (Taurus box on the wall.)
- Fig. 75. The Microlab's computer hardware configuration in 1992 (C. Hylands).
- Fig. 76. By typing in a login name, a lab member could obtain her/his charges for the month.
- Fig. 77. Lab Management interface of BCIMS.
- Fig. 78. CAPE terminal in the Microlab (Tim Duncan, 2001).
- Fig. 79. Graduate student Mark Hadley enabling a tool on a Pluto terminal (1995).
- Fig. 80. Grad. student Adam Fennimore using the CAPE terminal next to a process tool, with its own computer (2003).
- Fig. 81. Resource Utilization Monitoring System, RUMS (2003) [41].
- Fig. 82. Microlab computer infrastructure after the upgrades, in 2007.
- Fig. 83. Microlab web server infrastructure, 2007.
- Fig. 84. Mercury database schematic layout (Todd Merport, 2009).
- Fig. 85. Mercury structure, a dual three tier application system [40].
- Fig. 86. Interface of MercuryClient (2009).
- Fig. 87. Interface of MercuryWeb (Olek Proskurowski, 2009).
- Fig. 88. Hydra equipment control system (Todd Merport, 2008).
- Fig. 89. NanoLab Cory Hall Infrastructure Synchronization (T. Merport, 2010).
- Fig. 90. Three members of the first class in CMOS processing (1983-1984).
- Fig. 91. Arrival of the first tool dedicated to 6" wafers. Bob Connelly, equipment technician assisting with delivery, 2000.
- Fig. 92. ASML engineer with Sia Parsa, Microlab Process Engr. Manager and the first wafer printed on the new ASML.
- Fig. 93. Henry Heidbreder of Tystar Corp. assisting with upgrading the furnaces.
- Fig. 94. Mike Linan, Microlab staff engineer working on the gas delivery system of the LPCVD tubes.
- Fig. 95. More work needed on temperature control.
- Fig. 96. The last large tool to be placed, in an undersized space, GL1 in the Microlab, the Centura (2004).
- Fig. 97. Microlab migration schedule (W. Flounders, 2009).
- Fig. 98. Microlab membership, 1989-2010 (Rosemary Spivey).
- Fig. 99. Microlab membership by department in FY 2009/2010 (Rosemary Spivey).
- Fig. 100. Lab orientation seminar schedule.
- Fig. 101. Lab member's view of Microlab manager.
- Fig. 102. Lab members meeting in 1991.
- Fig. 103. EE 143 TAs, Jiang Tao and Charles Fields demonstrating microscope use to lab group (1974).
- Fig. 104. Head TA Jack Judy working with a student at the test station.
- Fig. 105. Processing at the sink in the undergraduate lab, 218 Cory Hall.

- Fig. 106. 298-12 seminar speaker, Prof. Arjun Saxena of Rensselaer Polytechnic Institute, with Prof. Cheung, and K. Voros (Fall 1996).
- Fig. 107. Cory Hall emergency evacuation (1993).
- Fig. 108. Microlab Manager, member of the Cory Hall Safety Committee.
- Fig. 109. Microlab informational booklet published in 1987.
- Fig. 110. Evolution of the Microfabrication Facility at Berkeley, ERL memorandum, 1989.
- Fig. 111. Informational booklet, published for the Tenth Anniversary celebration of the Microlab, 1993.
- Fig. 112. Hallway display on the second floor of Cory Hall, showing scenes from the Microlab (1988).
- Fig. 113. Profs. R. Muller and D. Hodges at the Tenth Anniversary reception (1993).
- Fig. 114. Maria Perez (center), Microlab process engineer talking with her supervisor, Debra Hebert, at the reception.
- Fig. 115. Banner of UGIM 2012 held at UC Berkeley.
- Fig. 116. View to W. from the new office. (Flat rooftop in forefront was Old Davis Hall, which was replaced by the new CITRIS bldg.)
- Fig. 117. Spacious new office, with manager's cubicle in the NW corner (1989).
- Fig. 118. Rosemary Spivey, Administrative Supervisor, at the reception desk.
- Fig. 119. Marilyn Kushner, who helped organize the reception, at her cubicle.
- Fig. 120. Dean David A. Hodges addressing the guests.
- Fig. 121. Prof. Spanos, the new Microlab Faculty Director.
- Fig. 122. Prof. W. G. Oldham, builder of the Microlab, with Prof. D. Angelakos, Director of ERL.
- Fig. 123. Prof. Ping K. Ko, Microlab Faculty-in-Charge (1984-1993), received the "Order of the Microlab".
- Fig. 124. Tenth Anniversary reception on the 4th floor of Cory Hall (March 1993).
- Fig. 125. In 1996 Microlab membership reached 200.
- Fig. 126. Celebrating 200 members of the Microlab (1996).
- Fig. 127. BSAC members celebrating. L-R: Michael Helmbrecht, Angad Singh, Jim Bustillo, David Horsley, Roger Hipwell, and John Evans.
- Fig. 128. Microlab mortgage burning.
- Fig. 129. Two PIs, whose lab fees helped pay off the mortgage.
- Fig. 130. Chancellor Berdahl's visit in 1997.
- Fig. 131. EMCORE equipment engineer at the new MOCVD system.
- Fig. 132. At the opening of the new MOCVD Laboratory.
- Fig. 133. Incoming Faculty Director Prof. Tsu-Jae King Liu with Prof. Spanos.
- Fig. 134. Professor Spanos received the "Order of the Microlab" at the end of his tenure as Faculty Director.
- Fig. 135. Banner for the opening of the refurbished DCL (2001).
- Fig. 136. DCL manager graduate students Pushkar Ranade and Kevin Yang, and the three PIs who financed the renovation.
- Fig. 137. Phill Guillory and Tim Duncan, BCAM engineer, cut the ribbon of the BCAM Metrology lab.
- Fig. 138. Let's have a party!
- Fig. 139. Chancellor Robert J. Birgeneau's visit (2006).
- Fig. 140. Poster of the Microlab's Closing Ceremony (April 2011).

List of Tables

- TABLE I Fabrication Equipment at the Start of the New Lab (1983)
- TABLE II Utilities Supported by Campus Services and by the Microlab
- TABLE III RUMS Sensor Status Display of Cory Hall Utilities
- TABLE IV Partial List of Equipment Depending on Utilities Maintained by Campus Services (2006)
- TABLE V RUMS Sensor Status Display of NanoLab Utilities (Partial View)
Inset: Line Chart of the Measured Data With Spec Limits, for DI Water Resistivity
- TABLE VI Construction Projects in the Neighborhood of the Microlab (1983-2009)
- TABLE VII Microlab Equipment List in 1993
- TABLE VIII Microlab Equipment in 2010
- TABLE IX Equipment Maintenance Assignments
- TABLE X Sample Page from the Maintenance Calendar (2011)
- TABLE XI Examples of Maintenance Task Executed by Process Staff
- TABLE XII Microlab Recharge Rates in 1988, 1990, and 2010

Glossary

A/P	Applications Programmer
ASCII	American Standard Code for Information Interchange (ascii)
BCAM	Berkeley Computer-Aided Manufacturing
BCIMS	Berkeley Computer-Integrated Manufacturing System
BLIMP	Berkeley Laboratory Infrastructure Monitoring Program; part of BCIMS
BMLA	Berkeley Microlab Affiliates
BSAC	Berkeley Sensor and Actuator Center
CAD	Computer-Aided Design
CAM	Computer-Aided Manufacturing
CIM	Computer-Integrated Manufacturing
CITRIS	Center for Information Technology Research in the Interest of Society
Class 100	Clean room specification: Less than 100 particles (of size 0.5 microns or larger) per cubic foot of air
CMOS	Complementary Metal-Oxide-Silicon (transistor or process)
CMP	Chemical-Mechanical Polishing
CNRI	Corporation for National Research Initiatives
COE	College of Engineering
CORAL	Common Object Representation for Academic Laboratories
DARPA	Defense Advanced Research Projects Agency
DCL	Device Characterization Lab
DEC	Digital Equipment Corporation
DI	De-Ionized (water)
DUV	Deep Ultra-Violet (wavelength)
EECS	Department of Electrical Engineering and Computer Sciences
EH&S	Office of Environment, Health & Safety
ERL	Electronics Research Laboratory
ERSO	Engineering Research Support Organization
ETR	Engineering Test Request
FTE	Full Time Equivalent (staff time)
FY	Fiscal Year (1 July – 30 June)
FYE	Fiscal Year-End (report)
GPIB	General Purpose Interface Bus (Hewlett-Packard)
GRA	Graduate Research Assistant
GUI	Graphical User Interface
HKUST	Hong Kong University of Science and Technology
HMMB	Hearst Memorial Mining Building
HR	Human Resources

IC	Integrated Circuit
IEOR	Department of Industrial Engineering and Operations Research
IML	Integrated Materials Laboratory
IT	Information Technology
JFET	Junction Field-Effect Transistor
LBL	Lawrence Berkeley Laboratory, officially: LBNL
LBNL	Lawrence Berkeley National Laboratory
LN	Liquid Nitrogen
LOX	Liquid Oxygen
LPCVD	Low Pressure Chemical Vapor Deposition
L&S	College of Letters & Science
ME	Department of Mechanical Engineering
MEMS	Micro-Electro-Mechanical Systems
ML	Microlab (Microfabrication Laboratory)
MOCVD	Metal-Organic Chemical Vapor Deposition
MOS	Metal-Oxide-Silicon (transistor)
MOU	Memorandum Of Understanding
MSE	Department of Materials Science and Engineering (since 2000)
MSME	Department of Materials Science and Mineral Engineering, renamed MSE in 2000
NE	Department of Nuclear Engineering
NMOS	N-channel Metal-Oxide-Silicon transistor
NSF	National Science Foundation
OS	Operating System
P/A	Programmer Analyst
PABX	Private Automatic Branch Exchange (telephone switching system)
PECVD	Plasma Enhanced Chemical Vapor Deposition
PI	Principal Investigator
PMOS	P-channel Metal-Oxide-Silicon transistor
RUMS	Resource Utilization Monitoring System
SAW	Surface Acoustic Wave
SEM	Scanning Electron Microscope
SDH	Sutardja Dai Hall
SIA	Semiconductor Industry Association
SPC	Statistical Process Control
SQL	Structured Query Language
SRC	Semiconductor Research Corporation
STAFF	Alpha-numeric interface; use restricted to staff members, part of the lab management software system, BCIMS

UC	University of California
UCB	University of California, Berkeley
UCOP	University of California, Office of the President
UCSD	University of California, San Diego
UCSF	University of California, San Francisco
UGIM	University/Government/Industry/Micro-Nano symposium
VLSI	Very Large Scale Integration
WAND	Alpha-numeric interface for the use of lab members, part of the lab management software system, BCIMS
WIS	Walker Interlock System (part of BCIMS)
Y2K	Year of 2000

I. Introduction

Microelectronics research and instruction began early at UC Berkeley, soon after the invention of the integrated circuit in 1958. In 1960, Professors D. O. Pederson, T. E. Everhart, and P. L. Morton in Electrical Engineering conceived plans for an integrated circuits research laboratory, the first in the world at a university, which became reality in 1962. This was the Integrated Circuits Laboratory in Cory Hall. To keep abreast with developments as the semiconductor industry grew by leaps and bounds during the '60s and '70s, a new lab was constructed in the early 1980s. The "old lab" was integrated into the new Microlab, which continued to operate for 28 years, until the end of 2010. The third stage of the research laboratory development culminated in the Marvell NanoLab, in a new building, Sutardja Dai Hall. For a year and a half, during the migration from the Microlab into the NanoLab, the two labs were run as one seamless operation, the former with diminishing equipment, the latter growing in number of tools and hours of usage. Finally, the doors of the Microlab were closed, management fully transferred and the history of the Marvell NanoLab began in earnest.

This report is intended to record the 28-year life span of the Microlab, with which Katalin Voros was affiliated from beginning to end; first as a process engineer, establishing a CMOS baseline, then as manager for 25 more years. During that time, together with the capable staff of the Microlab, under the directorship of three exceptional faculty members, management developed and maintained a world renowned university research lab. This happened gradually, sometimes by trial and error, since there were no precedents around for a cooperative academic lab of this size with the charter of financial self-sufficiency. But the Microlab did it and all who were affiliated with it can be proud of the lab's accomplishments: providing over its lifetime a working tool set and research space for 3801 students and researchers. The following pages describe, based on 25 yearly reports by Ms. Voros, how it was done.

II. History

The Monday, October 23, 1961 issue of *Electronic News* had a short article, “2 New Labs at California U. To Aid Integrated Circuitry.” The reporter writes: “Research in semiconductor integrated circuitry by the Electronics Research Laboratory of the University of California, here [Berkeley], will be enhanced next Spring with the addition of two laboratories, Prof. D. O. Pederson, director of ERL, said last week. He predicted that ‘substantially more than the current 10 per cent of ERL’s total effort will be devoted to this area,’ when the new semi-conductor integrated circuits fabrication laboratory and electron beam microscopy facility begin operating.”

And indeed, that is what happened. The plans became reality in 1962 with the construction of the Integrated Circuits Laboratory in Cory Hall. An 1,800 square-foot laboratory space, room 432, was extensively renovated at a cost of about \$30, 000, creating a vacuum systems and test area (432), furnace and epitaxial room with hydrogen plumbing (432AB), a chemistry room (432C), dark room (432D), and a microscope room (432E). Equipment to enable processing of complete bipolar circuits was added, which brought the total cost up to just under \$100,000. The first working integrated circuit on a $\frac{3}{4}$ -inch-diameter wafer, emerged at the end of 1962. The brochure, *Research Program in Electrical Engineering*, for the school year of 1963/64 proudly lists: “A special laboratory is equipped for diffusion and evaporation processes, metallographic studies, photo-resist etching and electroplating” and features “Graduate students David Hodges and Marina Bujatti (left) in the solid-state laboratory conferring with technician Dorothy McDaniel on microscopic appearance of integrated circuit and operating vacuum system for thin film fabrication.” (See Fig. 1 and 2.)



Fig. 1. M. Bujatti, D. McDaniel, and D. Hodges in the Integrated Circuits Lab (1963).

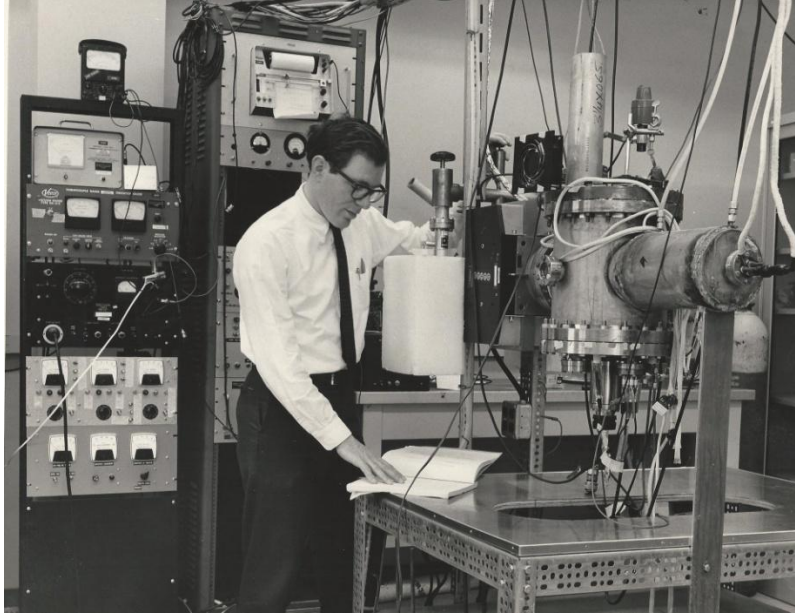

Fig. 2. Prof. Oldham at an early epitaxial deposition system (1963).

The following professors had research projects and graduate students in the early Integrated Circuits Lab: A. C. English, T. E. Everhart, W. G. Oldham, R. S. Muller, D. O. Pederson, R. S. Pepper, S. Wang, and R. M. White. S. R. Pedersen, research specialist was in charge of the lab, D. McDaniel and G. Becker provided technical support [1]. The Integrated Circuits Laboratory Manual compiled in 1966 lists processes for wafer preparation ($\frac{3}{4}$ inch diameter), epitaxial growth, photolithography, furnace operations, vacuum evaporation, in-line testing, assembly, and typical process schedules for bipolar transistors and junction FETs, as well as for MOS transistor fabrication. The first integrated circuit emerged in August 1963, a UJT¹ oscillator by G. Hachtel and G. Haines. D. Hodges completed an integrated bistable circuit in October 1963 [2]. (Fig. 3.)

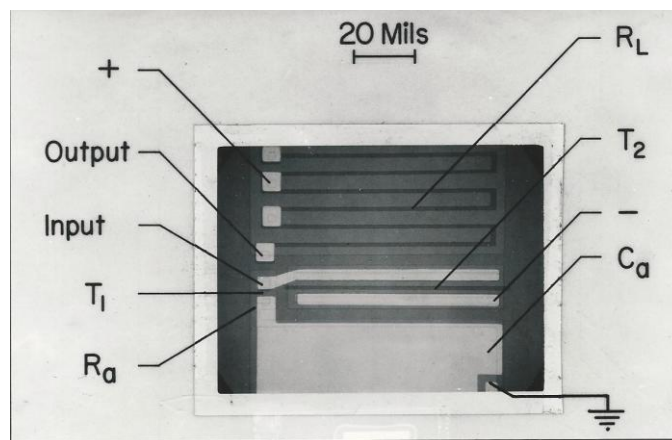

Fig. 3. Bipolar-JFET counting bistable circuit.
D. Hodges, Prof. Pederson (1963).

¹ Uni-junction transistor

During the 1960s and 70s many successful chips were coming out of the lab, which, followed by publications, enabled Berkeley EE research to be on the academic forefront of IC development. Examples are shown in Fig. 4-7.

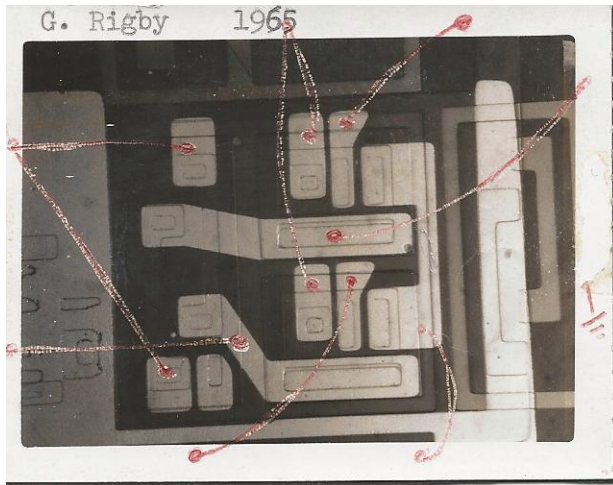

Fig. 4. Bipolar integrated circuit.
G. Rigby, Prof. Pederson (1965).

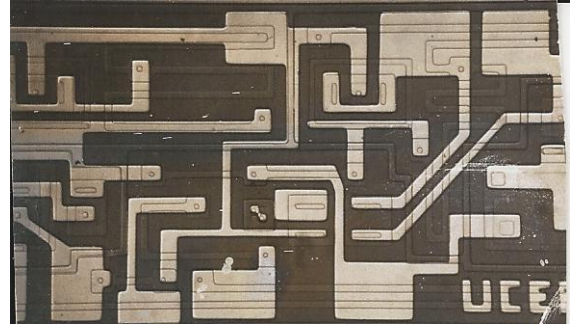

Fig. 5. Voltage controlled oscillator.
W. Howard, Prof. Pederson (1967).

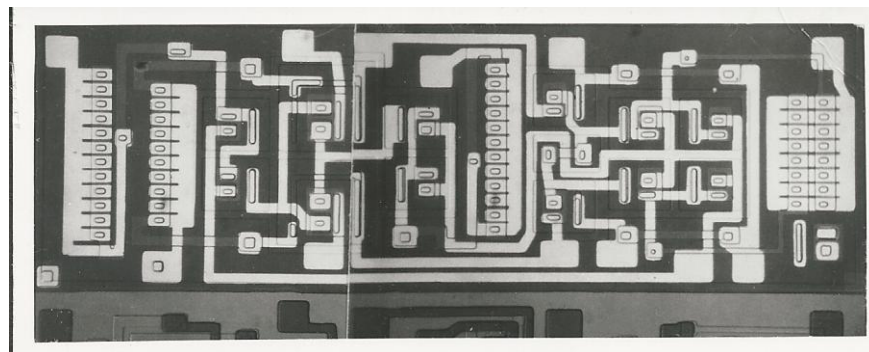

Fig. 6. Drift offset compensated amplifier.
G. L. Baldwin, Prof. Pederson (1969).

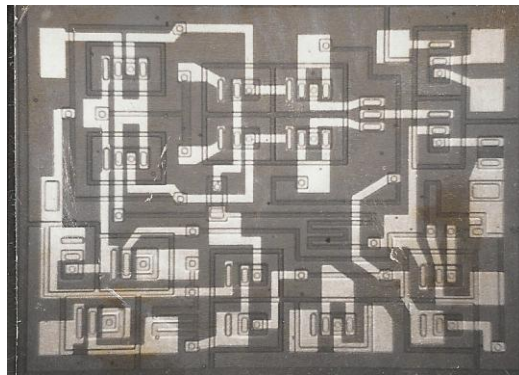
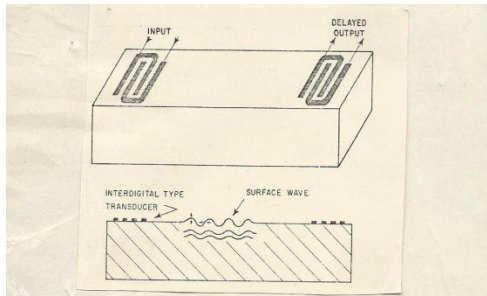

Fig. 7. Low-distortion, wide-band variable-gain amplifier.
W. Sansen, Prof. Meyer (1972).



Surface acoustic wave delay line for operation at 9 MHz.
 Substrate: lead zirconate-titanate ferroelectric ceramic (PZT-4).
 Transducing electrodes: Aluminum.
 Electromechanical coupling factor: $k^2 = 0.043$ (strongly piezoelectric-poled normal to propagation surface).
 Rayleigh surface wave velocity: Approximately 2×10^3 m/s.

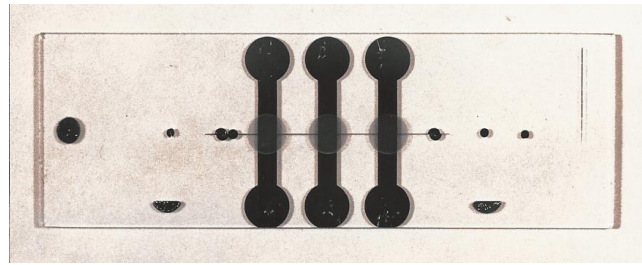

Fig. 8. (left) Surface acoustic wave device (SAW).
 F. W. Voltmer, Prof. White (1965).

Fig. 9. (top) Piezoelectric field-effect transistor strain transducers. J. Conragan, Prof. Muller (1969).

Besides circuits, sensors and actuator devices were fabricated in the lab early on. (Fig. 8 and 9.) For this reason the lab was often referred to as the Semiconductor Lab. The names Semiconductor and Integrated Circuits Lab were used interchangeably, referring to the joint facility available to all EE faculty and soon to researchers from other departments, such as Physics and Materials Science. The Integrated Circuits lab was unique for its time and set an early precedent for cooperative university labs in semiconductor research. Pooling resources enabled participating faculty to lead in a research area which requires heavy capitalization unobtainable for one professor alone. This model still works well at Berkeley, as we will see in subsequent sections.

Students of Professors Gray, Hodges, and Meyer were the major users of the Integrated Circuits Lab all through the 1970s. Their research at that time focused on mixed signal integrated circuits for communications and resulted in many innovative chips emerging from the lab. Examples are shown in Fig. 10, 11, 15, and 16.

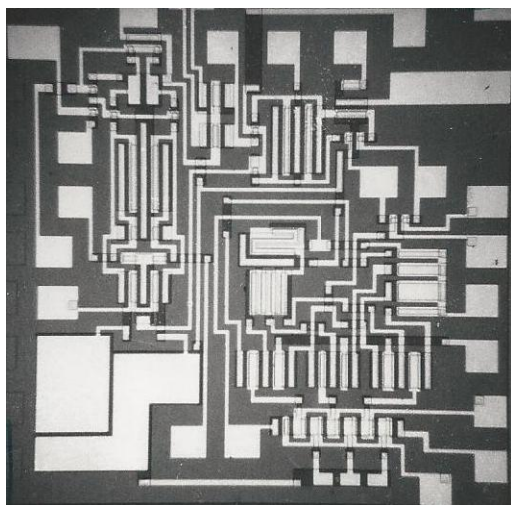

Fig. 10. Image contour extractor.
 P. Suci, Prof. Hodges (1975).

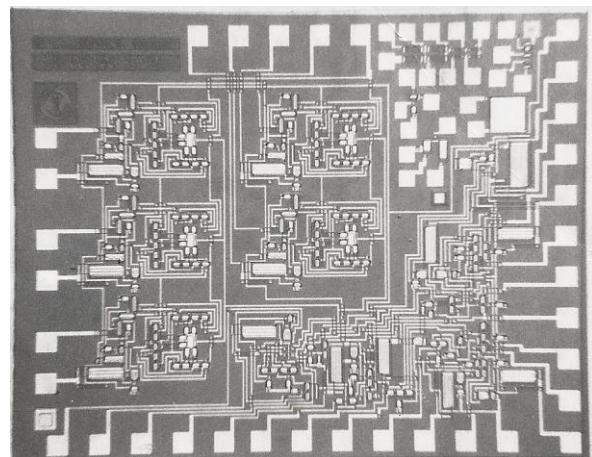

Fig. 11. PABX line-finder circuit.
 R. E. Suarez, Prof. Gray (1976).

Capabilities of the lab were continually enhanced to meet the requirements of more advanced circuit processing. This is another trait established early on which continued in the Microlab. Equipment was bought or built from joint grants and used by all lab members. (Fig. 12-14.)



Fig. 12. Prof. Gray and student Jim McCreary at the rubylith table.

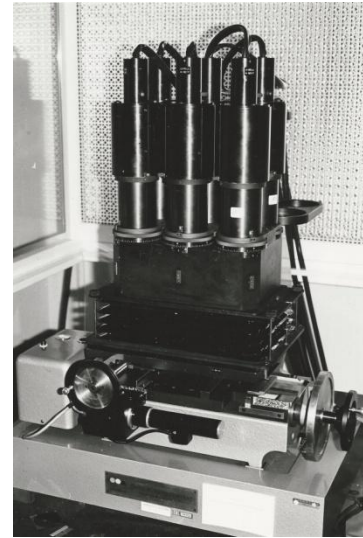

Fig. 13. Camera for mask making (1973).



Fig. 14. Prof. Hodges and student W. Black at the new ion implanter, Extrion 300, called Iona (1973).

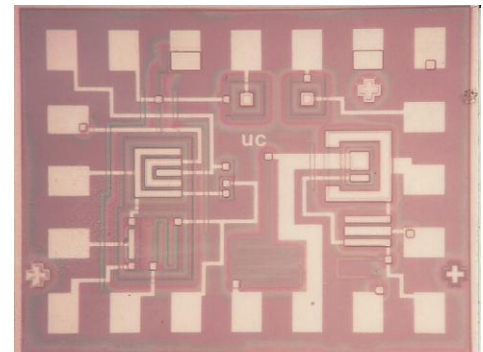

Fig. 15. First CMOS and first ion-implanted circuit made in the lab. W. Black, R. McCharles, Prof. Hodges (1976).

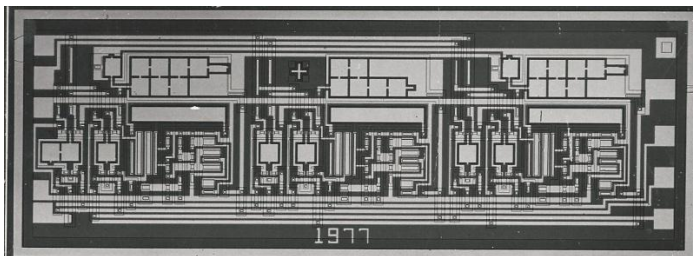

Fig. 16. (left) NMOS third-order switched capacitor precision elliptic low-pass filter.
D. J. Allstot, Prof. Gray (1977).

Developments in the semiconductor industry grew at an astonishing rate during the '70s. By the end of the decade it was clear that to maintain Berkeley's relevance and leadership, a new, modern facility was needed. Specific planning began in 1979 when the Chancellor assigned high priority to the project and the Regents endorsed it. A state appropriation of \$2.4 million was obtained and defended against state-wide budget cutbacks and freezes. In 1981 Governor Brown incorporated funding for the Berkeley Microfabrication Facility into his budget and planning for construction began in September 1981. Construction cost for the new facility, a renovation of existing space on the 4th floor of Cory Hall, was \$1.1 million. The remaining state funds were allotted for equipment for the new laboratory. Additional funding for research equipment was obtained from industry (\$1.1M), federal agencies (\$ 0.57M) and the Regents of the University of California (\$0.5M). Total cost of creating the Microlab was \$4.57M (1983) [3] [4].

Prof. W. G. Oldham was the driving force behind the building of the new lab. To develop the most efficient design for Berkeley's needs he consulted industrial colleagues extensively. The facility was to support ongoing research in the areas of integrated circuit design and processing, sensor and transducer devices, Josephson junction devices and circuits, as well as III-V compound devices and integrated optics. Processing areas were: a lithography center for all users, which included mask making, thin film systems dedicated to various metallurgies, a VLSI area with defect control. Multi-user common areas were designed to encourage the transfer of technologies within the diverse user community [5]. This concept was most successful throughout the existence of the Microlab. Fig. 17 shows the layout of the lab, which remained basically the same for 28 years.

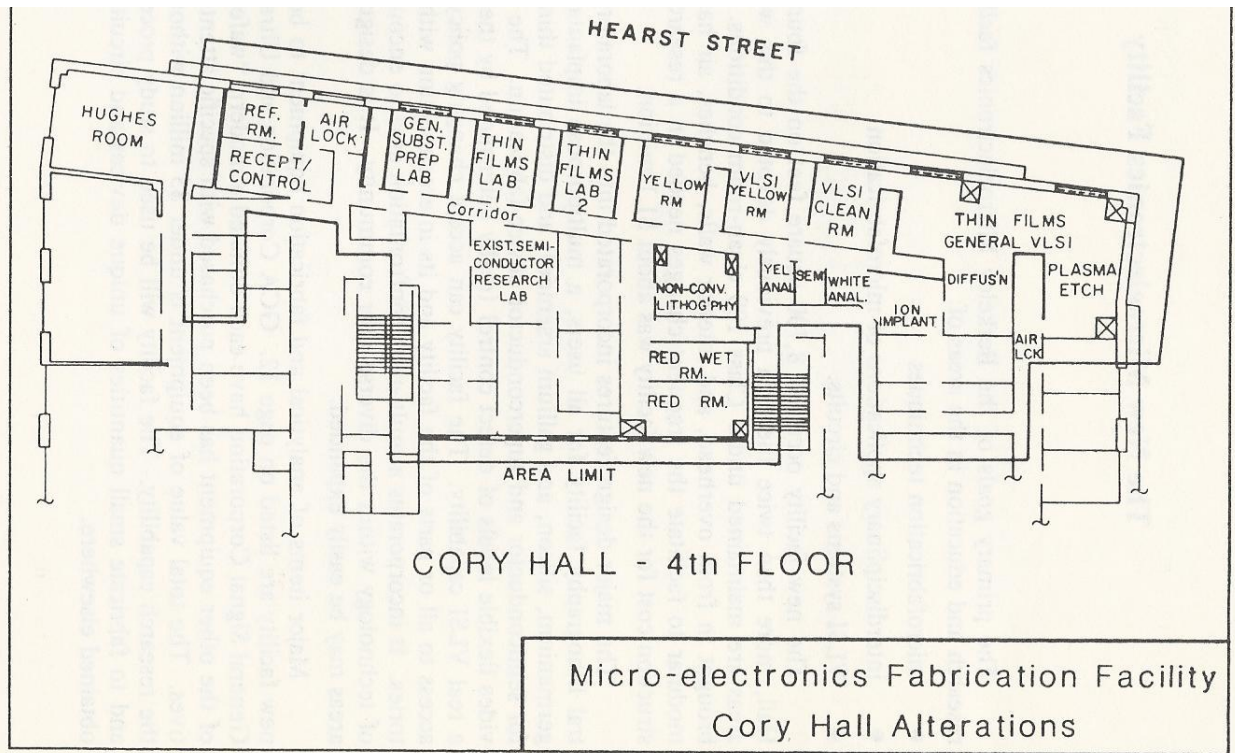

Fig. 17. Microlab layout as designed (1981).

The new lab area occupied 8,700 square feet, incorporating the Integrated Circuits Laboratory, the “old lab”. Operations were maintained in the “old lab” during the construction, except for the last three months when the two labs were joined as a single facility. Don Rogers, a longtime employee of the Department, was the overseer of the construction. (He became the first manager of the Microlab.) The new lab was created with modular walls, which could be reconfigured later as required by new developments. Utilities were overhead, color-coded for easy identification and visible through the ceiling. The deionized water system was placed in the building’s mechanical room one floor above, with a 2000 gal. holding tank on the roof. Two air conditioning systems supplying the lab were placed on the roof, also two sink exhaust fans. Nitrogen gas was plumbed in from a liquid nitrogen vessel located in the backyard of Cory Hall. The new lab was a text book example of how to fit a modern semiconductor lab into an old building² not designed for temperature and humidity controlled clean room (class 100)³ labs.

An interesting side note: to see how the modular walls are assembled, the contractor was asked to demonstrate the process by a side project, constructing a small lab for an undergraduate class, in 218 Cory Hall. They did it in two days thereby gaining Prof. Oldham’s approval. (Fig. 18.)



Fig. 18. Modular lab walls (1982).

Another interesting idea of Prof. Oldham’s was to install a time lapse camera in the construction site of the new lab, which enabled to include some interesting footage in the video film produced about Microlab operations in 1989.

The equipment list contained both newly donated tools and also those from the old lab. New furnaces, including two LPCVD⁴ systems, a pattern generator for mask making and a 10X wafer stepper gave great impetus to 4” diameter wafer processing. For the full list see Table I. Measurement instruments included 3 old and one new SEM⁵, a line width and film thickness measurement tool, a profilometer and an ellipsometer. Sinks for wafer cleaning and chemical processing were in place and the new Microlab was ready for researchers.

² Cory Hall was designed before WW II and building completed in 1950 [53].

³ Less than 100 particles (of size 0.5 microns or larger) per cubic foot of air

⁴ Low Pressure Chemical Vapor Deposition

⁵ Scanning Electron Microscope

TABLE I
FABRICATION EQUIPMENT AT THE START OF THE NEW LAB (1983)

FABRICATION EQUIPMENT	
Furnaces	12-4" Tylan computer contr.; 9-3"; 4-2"
Lithography	1-GCA 10x; 1-Ultratech 1x; 1-Canon 4x; 2-Contact printers; 1-mask duplicator
Pattern generation	1-GCA 3600; 1 Gyrex 1005A; 1-6 barrel S/R
Implantation	1-Extrion 20-200 (modified for versatility)
Thin films	4 4" tubes, 2 2" tubes LPCVD; 5 evaporators; 5 sputtering systems
Bond & Package	Wire bonder; dicing saw
MBE	1-Riber (Instruments SA)
Ion milling	1-VEECO Microtech
Plasma etching	1-Lam Autoetch 480 1-Plasma Therm 12" Parallel Plate etcher 2-Technics Parallel Plate etcher 1-Technics 4" Barrel etcher
RO Water	1-Continental Water Reverse Osmosis system

A dedication ceremony was held on March 23, 1983, the date on which the life of the Microlab officially began, to last for 28 years. (Fig. 19 and 20.)

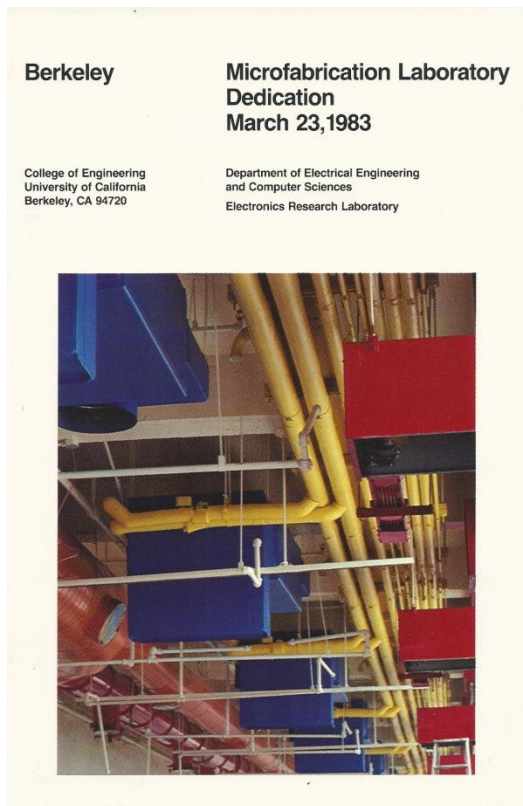

Fig. 19. (left) Front cover of the booklet prepared for the dedication of the new lab. Shown are the color-coded utility lines in the ceiling [6].

Fig. 20. (right) Arched hallway lends the laboratory a spacious feeling upon entry (1983).

III. Timeline

This section lists the major events of each year, as the facilities and operation of the Microlab evolved. The chronology is based on Year-End Reports submitted by K. Voros to the Faculty Director, from 1986 – 2012. These are included in the Appendix, a separate EECS Technical Report. See <http://www.eecs.berkeley.edu/Pubs/TechRpts/2013>.

Later sections will present organizational details, operations, including management of resources (staff, facilities, finances), control, planning and development, and public relations activities.

- 1983** Microlab opens for research (March 1983) [6]. Manager **Don Rogers; Bob Hamilton**, Maintenance Supervisor. Fall Semester: first graduate class in the Microlab, EECS 290N, Advanced Topics in Integrated Circuits Processing, the Berkeley CMOS Process. Process equipment and computers installed by staff, processes brought up by students. Information management software development starts: WAND. Prof. Oldham is Faculty in Charge. Construction of the CAD/CAM Facility on the 5th floor of Cory Hall begins.
- 1984** Spring semester: graduate class continues processing. Test chip documented [7]. Fall semester: process documented [8]. Fall semester: Katalin Voros is Head TA for EE 143 Processing and Design of Integrated Circuits and graduates with an MS in Engineering Science (EECS) [9]. **Prof. Ping K. Ko, Faculty in Charge** of the Microlab.
- 1985** Equipment installation, computer management system development continues: STAFF. Equipment computer control system hardware, designed by Alex Para, installed: Taurus. Katalin Voros starts as process engineer. NMOS process completed, working devices in July 1985 [10]. CAD/CAM Facility dedicated. (September 1985) [5] **Rosemary Spivey**. Administrative Supervisor; **Robin Rudell**, adm. assistant, process supervisor in 1987.
- 1986** Process modules developed, N-well CMOS process completed ($L=2.4\ \mu\text{m}$ working dev.) Process staff trained. Microlab Manager, Don Rogers retires (Nov. 1986).
- 1987** P-well CMOS, with new process modules [11], completed ($L=3\ \mu\text{m}$ working devices) P-well CMOS, double metal process completed. **Katalin Voros Microlab Manager** (January 1987). Operating budget breaks even but there is a \$400+K debt. BCIMS⁶ development continues [12], Techjob, RESERVE completed [13]. Informational booklet published [14].
- 1988** Staff structure developed and finalized: equipment and utilities maintenance (6, including supervisor Bob Hamilton), process staff (4, including supervisor Robin Rudell), administration (2, including supervisor Rosemary Spivey), computer support (2 including supervisor David Mudie).

⁶ Berkeley Computer-Integrated Manufacturing System

EE143 process redesigned, lab manual published [15].
Process staff continues CMOS runs, new test chip developed [16]; 9 used/new pieces of equipment installed/retrofitted (cpa, lam2, 2nd poly-Si tube, for BSAC⁷)
Finances: started to pay off “mortgage” at \$50K/year.
BCIMS development: facilities monitoring, BLIMP [18].

- 1989** Lab membership increased to 150/month (from less than a 100 at the start). New mechanical service room 413 Cory (Pump room) established. Expanded, **renovated office** for Microlab staff. Ion implanter decommissioned (obtained in 1975)
New supervisors: Debra Hebert, process and Lauren Massa, computers.
BCIMS: facilities layout program, FLIP [19].
Evolution of the Microfabrication Facility at Berkeley report published [20].
Informational video, *Microfabrication at Berkeley*, completed (Robin Rudell).
- 1990** Microlab space fully utilized; beginning of cooling water capacity problems.
Regular process monitoring started. Autoprobe installed [21].
Year-End Reports by all A&PS⁸ employees of the Microlab. First publication of a separate Microlab Financial report at the end of Fiscal Year 89/90 (30 June 1989).
Microlab staff featured in EECS/ERL News [22].
BCIMS work continues with Work in Progress (WIP) development [23] [24].
New equipment problem reporting software, FAULTS, installed [25].
Separation of CIM research and Microlab “production CIM”.
- 1991** Computer systems administrator hired by the Microlab, **Mark Kraitchman**.
Development work continues part time with Lauren Massa and Christopher Hylands.
James Bustillo hired by BSAC, the largest research group in the Microlab.
KV participating in the Competitive Semiconductor Manufacturing research program (1991-2001) [26]. Departmental reorganization, **Microlab reporting to ERL**.
- 1992** Utilities problems with cooling water capacity and air conditioning reliability continue to hamper operations. Tool additions: Lam Rainbow etcher, low stress Si-nitride tube for BSAC. Staff **baseline** project re-established (Spanos), engineer hired (Fang).
Release as “Research Software” lab management software, BCIMS [27].
- 1993** **Professor Spanos** becomes Microlab **Faculty Director**.
First IML⁹ tool, SEM/e-beam writer, installed in 107 Cory Hall, as part of the Microlab.
UCB/MIT joint NSF¹⁰ proposal for NNUN¹¹ **not** funded. K Voros Chair of EECS/ERL technical supervisors group (until 2005). 10th anniversary celebration (March 1993).
New informational booklet published for 10th anniversary [28].

⁷ Berkeley Sensor and Actuator Center, started in 1986 [17]

⁸ Administrative and Professional Staff

⁹ Integrated Materials Laboratory (IML), funded by a joint MSE/Physics/EECS NSF grant, managed by MSE

¹⁰ National Science Foundation

¹¹ National Nanofabrication Users Network, call for proposal NSF 93-43

- 1994** Campus Physical Plant replaced the ailing lab air conditioner. Physical space capacity expansion through “satellite” laboratories. Cory Hall **Machine Shop under Microlab** management. New process supervisor, Maria Perez. New test chip developed for baseline by the BCAM¹² group, for automatic testing [29]. Started to organize Solid State Devices and Technology graduate seminars. The Microlab’s first website was established. EECS at Berkeley brochure illustrated with photos from the Microlab [30].
- 1995** Equipment monitoring (SPC¹³) extended to 22 tools. Satellite labs included in BCIMS. New process supervisor: John Knudsen. Baseline report published [31]. Lauren Massa documented BCIMS [32]. New video, *Microfabrication Research at Berkeley*, released (Reka Pigniczky). Microlab web portal updated. University Laboratories Network mailing list established: labnetwork@mtl.mit.edu.
- 1996** 6” upgrade plan developed (3-phase, incremental, 1998-2004). Assessment of opportunities for a new lab. Lab **membership** reaches **200**; BSAC is the largest group, supporting their own processes [33]. Baseline Engineer: Goubin Wang. Joint computer software project started with the labs of Stanford and MIT, in anticipation of Y2K¹⁴. Departmental reorganization of technical staff: **K. Voros, Operations Manager**, to manage the EECS Computer Services Group (until 1999) and Special Projects (until 2000). **J. Bustillo** becomes **Microlab Technology Manager** (half time).
- 1997** Preparations for 6” upgrade. Inherited debt, from construction of the Microlab, retired. (Mortgage burning.) **BMLA**¹⁵ program established for industrial members.
- 1998** 6” equipment development: Si-Ge LPCVD furnace, CMP¹⁶, deep Si plasma etcher, front-back side aligner. New supervisors: **Sia Parsa**, process. IML under Microlab management, R. Prohaska development engineer. Impact of HMMB¹⁷ construction next door. **MEMS Exchange**¹⁸ participation. Planning for a new lab started. (Memo to Dean.)
- 1999** 6” upgrade: phase II in full swing. New baseline engineer, L. Voros (no relation to K. Voros).
- 2000** **Prof. Tsu-Jae King Liu** becomes Faculty Director. Technology Manager position open. Phase II of 6” upgrade: lithography, LPCVD furnaces. Baseline report published (twin well, 1µm technology) [35]. Safety video, *Hop on Board with Safety*, produced (Laurel Reitman) [36]. Computer staff supervisor: **Todd Merport**.

¹² Berkeley Computer-Aided Manufacturing group, Prof. Spanos, Principal Investigator (PI)

¹³ Statistical Process Control

¹⁴ Year of 2000

¹⁵ Berkeley Microfabrication Laboratory Affiliates

¹⁶ Chemical-Mechanical Polishing

¹⁷ Hearst Memorial Mining Building

¹⁸ DARPA-funded program, managed by Corporation for National Research Initiatives (CNRI) [34]

- 2001** Technology Manager, **A. W. Flounders** started. (Shared with BSAC.) Equipment control hardware upgraded to new hardware/software system, **WIS**¹⁹. **CORAL**²⁰, the result of Stanford/MIT/UCB's joint software project, tested. (We opted out.) Summer internship for high school girls started. Microlab video updated (Reitman) [38]. DCL renovation (407/409 Cory) New engineering building approved, including a new lab in it (to replace the Microlab) Project name: CITRIS²¹
- 2002** 9000 gal. liquid nitrogen vessel installed. 6" upgrade process development continues. Report on the 6" baseline process published [39]. New baseline engineer: A. Horvath. New computer integrated lab management system design started. (F. Varju, T. Merport) Design of the new lab well underway.
- 2003** New cooling water loop. (6" upgrade) New computer lab management system: **MERCURY**²², development in progress. New facilities monitoring system, **RUMS**²³, deployed [41]. Website redesigned (9 panels) [42]. New building/new lab design negotiations, "diversification" and "value engineering"²⁴. Building project divided into Phase I and Phase II.
- 2004** 6" upgrade completed, final report submitted [43]. **IML closed**. K. Voros' time reduced to 80%. A. W. Flounders full time Microlab Technology Manager. **Prof. N. Cheung Interim** Faculty Director (until 2006). Phase I of new building starts (demolition).
- 2005** ERL becomes **ERSO**, Prof. Spanos Associate Dean for Research. 0.35 μm CMOS baseline process development. Report submitted [44]. New baseline engineer: G. Vida. New building/lab: budget negotiations. Construction halted.
- 2006** Prof. King Liu is back as Faculty Director. New baseline engineer: A. Pongracz. Construction of CITRIS building resumes, named Sutardja Dai Hall, the new lab in it **Marvell NanoLab**.
- 2007** Re-plumbing of nitrogen gas lines in Cory Hall. Planning of computer needs in the new lab. Mercury software development, testing; hardware procured. Baseline report V., with new test chip, published.[45]. New baseline engineer: L. Petho. New lab: no budget for the move, fundraising starts.
- 2008** **Faculty Director Prof. Ming Wu**. New building/lab close to completion. New e-beam writer, Crestec, installed in Cory Hall. Mercury management software/hardware ready for deployment. Marvell NanoLab website established [46]. Fundraising video produced (Flounders) [47]. Planning of equipment move. Baseline report VI. published [48].

¹⁹ Walker Interlock System

²⁰ Common Object Representation for Academic Laboratories; renamed BADGER in 2013 [37].

²¹ Center for Information Technology Research in the Interest of Society, funded by the State of California and private gifts

²² (Not an acronym) Presentation at UGIM 2012 [40].

²³ Resource Utilization Monitoring System

²⁴ Cutting out capabilities to stay within budget.

- 2009** Grand opening of Sutardja Dai Hall, Feb. 2009. Marvell lab fit-up starts in June 2009. 1st tool to move, Crestec e-beam writer. In December Marvell lab opened for operations with 2 tools. Start of 2 lab operations. Last baseline in the Microlab started, test chip includes MEMS structures. Report VII. published [49].
- 2010** **W. Flounders Marvell NanoLab Executive Director.** Equipment move in high gear. Computer control added immediately. Accounting for 2 labs separate but one invoice to principal investigators. Lab orientation sessions and requalification on tools in new lab required. Operating manuals updated as the move progressed. Microlab operations ceased on 29 December 2010 (with 8 tools remaining to be moved). Baseline Engineer: A. Szucs.
- 2011** Remaining tools moved; chemical inventory zeroed out, June 2011; general lab clean up. Microlab **Closing Ceremony held in April 2011**, 28 years after the official opening. K. Voros at 50% from June 2011, retains Machine Shop management. (Ret. June 2013)
- 2012** Final baseline report, the first CMOS run in the new Marvell lab [50]. Conferences organized: ISTDm 2012 [51] and UGIM 2012 [52].

IV. Organization

This section describes the organizational environment, up and down the reporting and support structure, in which the Microlab and its predecessor, operated. The delineation was not always sharp but during the last 20 years of steady-state operation the Faculty Director was the only immediate overseer of the Microlab. This clear-cut reporting line played a major role in developing and maintaining a well-run unit.

The Microlab’s administrative control unit was the Electronics Research Laboratory, or ERL. ERL was closely interwoven with Electrical Engineering. A short history:

Electronics Research Laboratory (ERL) 1952 – 2005

The **Electronics Research Laboratory** was established in 1952 “to coordinate [research] policies and to help all faculty members in their search for research support.” [53] At first it was set up within the Department of Electrical Engineering.

1952-1956 **Professor John R. Whinnery**, Vice Chairman
in Charge of the Electronics Research Laboratory

In 1956 ERL became a formal organized research unit. “Organized Research Units (ORUs) are organized around broad substantive research topics (e.g. international affairs, information technology, the environment). As such, they draw into their research programs faculty and students from multiple departments and disciplines.” [54]

1956-1960 **Professor Samuel Silver**, Director of Electronics Research Laboratory

1960-1964 **Professor Donald O. Pederson**, Director of ERL
(Integrated Circuits lab built, 1962-63)

1964-1984 **Professor Diogenes Angelakos**, Director of ERL (Microlab open, 1983)

1985-1990 **Professor William G. Oldham**, Director of ERL

1986-1987 Professor Paul R. Gray, Acting Director of ERL

1990-1995 **Professor Michael E. Lieberman**, Director of ERL

1996-1999 **Professor S. Shankar Sastry**, Director of ERL

1999-2000 Professor Jeffrey Bokor, Acting Director of ERL

2000-2004 **Professor Albert Pisano**, Director of ERL

2004-2006 **Professor Costas J. Spanos**, Director of ERL

2005 ERL moves under the COE, from the Office of The VC for Research

2006 ERL becomes **ERSO**, Engineering Research Support Organization. ERSO functions as a central hub, providing research administration support to all research centers, departments, and affiliated ORUs in the UCB College of Eng. [55]

2006-2008 **Professor Costas J. Spanos**, ERSO Director,
Associate Dean for Research

2008-2012 **Professor Tsu-Jae King Liu**, Associate Dean for Research
2009 Marvell NanoLab occupancy begins.

With EECS and ERL closely connected, ERL being the research arm of the Department, staff was often shared, basically along functional lines. This situation presented no problem in most cases; however, defining the reporting line for the Microlab was challenging in the early years. This was resolved in 1991, after the retirement of the Department Engineer, Wil Zeilinger, when the line of reporting went directly to the Microlab's Faculty Director. Prof. Ping K. Ko. This was necessary because the best interest of the lab required involved faculty leadership.

Regardless of the administrative reporting structure, the Department always demonstrated proud ownership and great support for the Microlab throughout the lab's history. One of the ways support was demonstrated was by providing funding for the lab manager's salary, throughout the Microlab's existence. This policy was faithfully adhered to by the two long-time departmental Management Services Officers (MSOs), Ruth Tobey and Kate Riley. Below is the list of EECS Chairs during the life of the Microlab:

Department of Electrical Engineering and Computer Sciences (EECS)

Chairmen during the Life of the Microlab (1983 – 2011)

1983 - 1985 Professor Donald O. Pederson – Official opening of the Microlab (March 23 1983)

K. Voros hired as Process Development Engineer (January 1985)

1985 - 1989 Professor Eugene Wong – K. Voros hired as Microlab Manager (Jan. 1987)

1989 - 1990 Professor David A. Hodges

1990 - 1993 Professor Paul R. Gray – Microlab 10th Anniversary Celebration (March 1993)

1993 - 1996 Professor David G. Messerschmitt – Dept. technical services reorganized (1996)

1996 - 1999 Professor Randy H. Katz

1999 - 2000 Professor Richard Newton

2000 - 2004 Professor S. Shankar Sastry – CITRIS building approved (2001)

2004 - 2006 Professor Jitendra Malik

2006 - 2008 Professor Edward A. Lee

2008 - 2010 Professor Stuart J. Russell

2010 - 2012 Professor Costas J. Spanos – Microlab closed in Cory Hall (December 2010)

Closing Ceremony April 2011

The **College of Engineering** worked closely with the departments on many fronts, most importantly, in fundraising for major projects. This was especially important, when Microlab management started to develop plans for a new lab. **Deans** during the life of the Microlab and its predecessor were:

- John R. **Whinnery**, EE (1959-1963) [53]
- George J. **Maslach**, ME (1963-1972) [56]
- Ernest S. **Kuh**, EECS (1973-80)
- Karl S. **Pister**, CEE (1980-1990) [57]
- David A. **Hodges**, EECS (1990-1996) [58]
- Paul R. **Gray**, EECS (1996-2000)
- A. Richard **Newton**, EECS (2000-2007)
- S. Shankar **Sastry**, EECS (2007-present)

See *Deans' Gallery* at <http://coe.berkeley.edu/about/history-and-traditions/deans.html>.

The Microlab was an independent recharge operation of ERL, under the supervision of the Faculty Director. It was the lab's great fortune and benefit to have had three long-term, dedicated professors in this assignment, with whom an excellent, well-run organization, could be built, Professors **Ko**, **Spanos**, and **King Liu**.

Microlab Faculty Directors 1983 – 2011

March 1983 – June 1984	Prof. W. G. Oldham
July 1984 – June 1993	Prof. Ping K. Ko
July 1993 – June 2000	Prof. Costas Spanos
July 2000 – July 2004	Prof. Tsu-Jae King Liu
August 2004 – July 2006	Prof. Nathan Cheung (interim)
August 2006 – June 2008	Prof. Tsu-Jae King Liu
July 2008 – until closure	Prof. Ming Wu

The first staff manager of the Microlab was Don Rogers, 1983-1986. Katalin Voros took over in 1987 and managed the lab for 23 years, until it closed its doors. With her, from the opening day to the closing, were Robert Hamilton, Facilities Manager and Rosemary Spivey, Manager of Administration. These core staff members, along with the Faculty Directors, were the builders of a stable, self-supporting, independent recharge organization. However, this could not have happened without the unflagging support of EECS/ERL leaders and faculty members.

In 1996 the Department reorganized its technical support staff and K. Voros was asked to manage two other recharge units: the Computer Services Group (CSG) and Special Projects; she had already been managing the Cory Hall Machine Shop since 1994. In return, a half-time Microlab Technology Manager position was funded. James Bustillo, who was already working for BSAC, filled the half-time position until 2000. Dr. W. A. Flounders came on board as Technology Manager in 2001, just in time to participate in the design and construction of the new Marvell NanoLab. In 2011 he became Executive Director of the new lab. Thus the tradition continues.

The following supervisors made up the middle tier of management:

Process: Robin Rudell (1987-89), Debra Hebert (1989-94), Maria Perez (1994-95), John Knudsen (1995-98), Sia Parsa (1998-2010).

Computers: David Mudie (1988-89 and 1997-98), Lauren Massa (1989-1991), Mark Kraitchman (1991-97), Todd Merport (1999-2010).

Further details on the staff structure of the Microlab will be discussed in the Staff section of this report.

Microlab Management Team 1983 – 2010

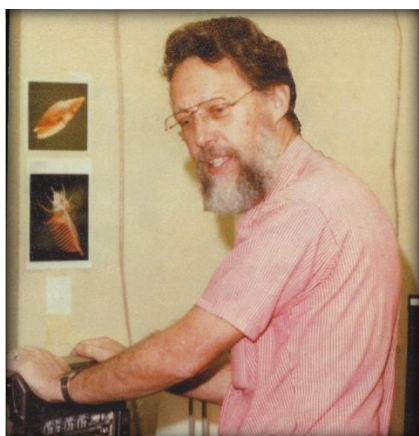

Don Rogers
Microlab Manager, 1983-1986



Katalin Voros
Microlab Operations Manager, 1986-2010



Bob Hamilton
Equipment and Facilities Manager, 1983-2010



Rosemary Spivey
Administrative Manager, 1985-2010



Jim Bustillo
Technology Manager
1996-2000



Sia Parsa
Process Engineering Manager
1998-2010



Bill Flounders
Technology Manager
2001-2010

V. Operations

This section describes Microlab operations, including management of resources: staff, facilities, finances; planning, communications, and controls. These activities are interrelated as shown in Fig. 21. The performance of staff managers at the University of California is evaluated loosely based on this general concept. Managers are expected to develop for themselves the substance of each of these areas, and how it is applied in their own operation. What operational management meant and how it developed in the Microlab, is the subject of this section.

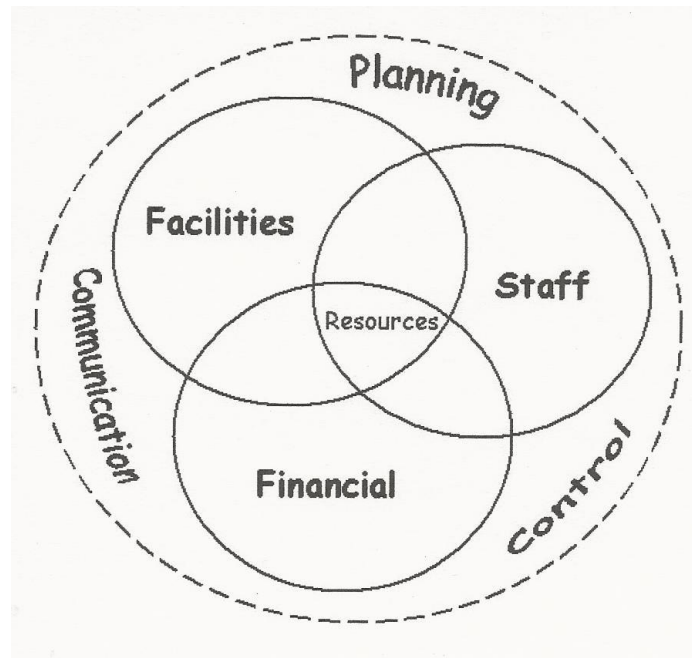

Fig. 21. Operational management: systems and controls.

Management of Resources

1. Facilities

Laboratory Space

Fig. 17 shows the layout of the Microlab as designed and built in 1983; the original space, 8,700 square feet, did not include staff offices, service areas, nor storage space. Soon it became painfully apparent, that, without these, lab operations are hampered. Professor Ping Ko, Faculty in Charge, requested additional space, which was granted by the Chair of EECS, Prof. D. Hodges. First an electronics service room (455 Cory) and a chemical storage room (457) were added. Both of these also doubled as equipment parts and quartzware store rooms. Next came expansion of staff office space (406), creation of a lab-materials storage room (421), a mechanical service room (“pump room” in 413). The “grand opening” of the new office and service rooms was held in December 1989.

In 1990 the Device Characterization Lab (DCL), owned by the device group, was moved from the third floor to 407 Cory, adjacent to the Microlab. 409 housed the Microlab's automatic wafer tester (autoprobe) and Professor Spanos' metrology instrumentation. Microlab staff assisted with maintenance; in return, Principal Investigators (PIs) Professors Hu and Ko allowed controlled use of the probe stations by non-device group lab members. In 2001 the DCL (407/409 Cory) went through a major renovation, financed by participating PIs. Work included installation of air conditioning, new ceiling, flooring, painting, power upgrade, and new benches. The DCL's controlled open-use policy continued under Prof. King Liu.

Fig. 22 shows the lab area under Microlab management by 1993. In 2008 the DCL and Metrology lab were relocated, to make room for new faculty, Professor Maharbiz' Biotic-Abiotic Interfaces lab. Moving walls and equipment, repurposing, upgrading along the way, was the pattern of facilities development throughout the history of the Microlab.

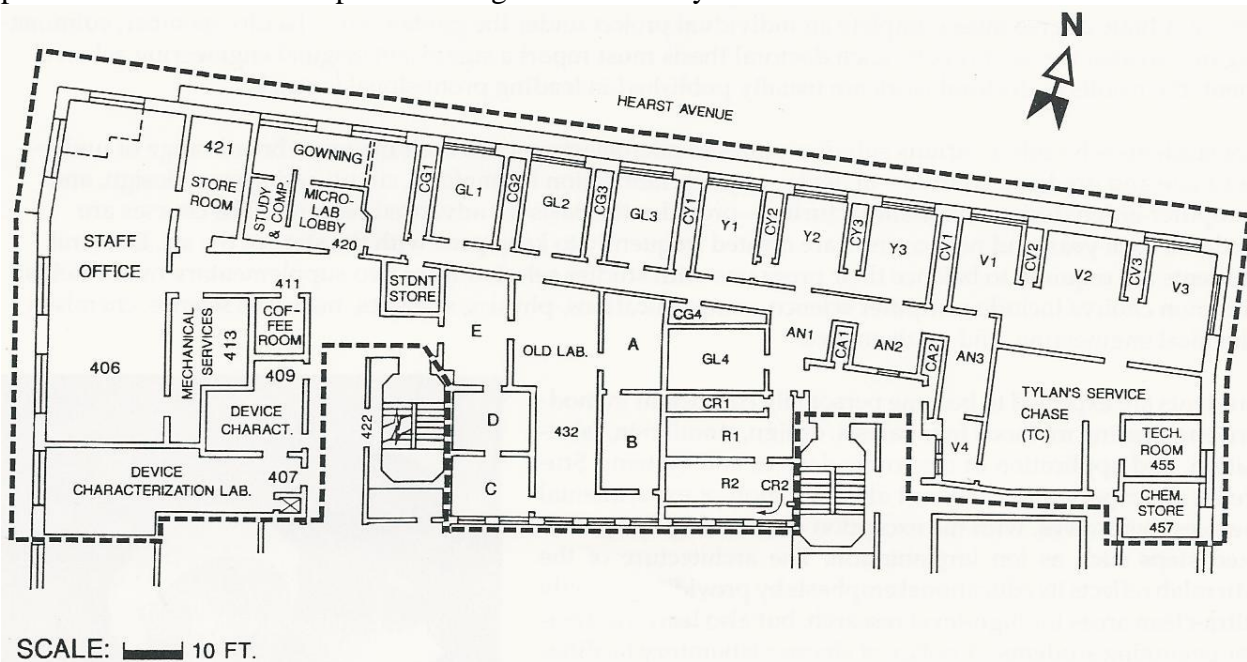

Microfabrication Laboratory, fourth floor, Cory Hall. Total area is approximately 10,000 square feet.

Fig. 22. Microlab layout in 1993.

Space inside the Microlab was fully occupied in the first five years. After that, new equipment could be sited only if an old one was removed. As a rule, new tools were larger, with more stringent utilities requirements, and placing them in the space of the old tool required rearrangement of other equipment in the immediate area. As a result, the Microlab became densely packed and by 1990 utilities capacity problems began to appear.

Satellite Labs

In 1993 the Microlab began to expand into "satellite" labs on the first floor of Cory Hall. When an NSF equipment grant, jointly submitted by MSE/Physics/EECS was funded, the Integrated Materials Lab (IML) was created with components in the home of each of the three departments, in the Hearst Memorial Mining Building (HMMB), Le Conte Hall, and Cory Hall. The Microlab

received a SEM/e-beam writer, which was sited in room 107 Cory Hall. This tool was connected to Taurus, the ML's computerized equipment control system, as all the tools in the main lab as well as those in the satellite labs. In 1998, when the HMMB was decanted for seismic upgrade and renovation, the MSE portion of the IML tools were divided up and moved temporarily to Physics in Le Conte Hall and to Cory Hall. At the same time, IML came fully under Microlab management. IML tools were located in three different buildings (until 2003 when HMMB could be reoccupied).

Also in 1998, the Microlab received an AMAT P5000 low temperature plasma deposition cluster tool, as matching fund for yet another grant. This tool was so huge that it could not be placed in the Microlab; thus, space was carved out of 188 Cory to create 190, which, with the addition of a CMP tool and cleaning station, became the Planarization Lab.

The same type of expansion occurred in 2000, with the creation of the Thin Films Lab, in 144AB Cory Hall. The Novellus 5-chamber cluster tool for deposition of Al, Al/Si, Ti, Ti/N was crowded into two small rooms, with the wall removed in between. Also, office space was made available in 178M, for four Microlab staff people supporting the satellite labs.

These expansions could only have occurred with the agreement of the professors, who gave up their dedicated research space for the satellite labs. The role of the Faculty Directors in these space negotiations cannot be over-emphasized. (Professors Spanos, King Liu, Cheung.) Fig. 23 shows the schematic layout of the Microlab and its satellites, in 2000.

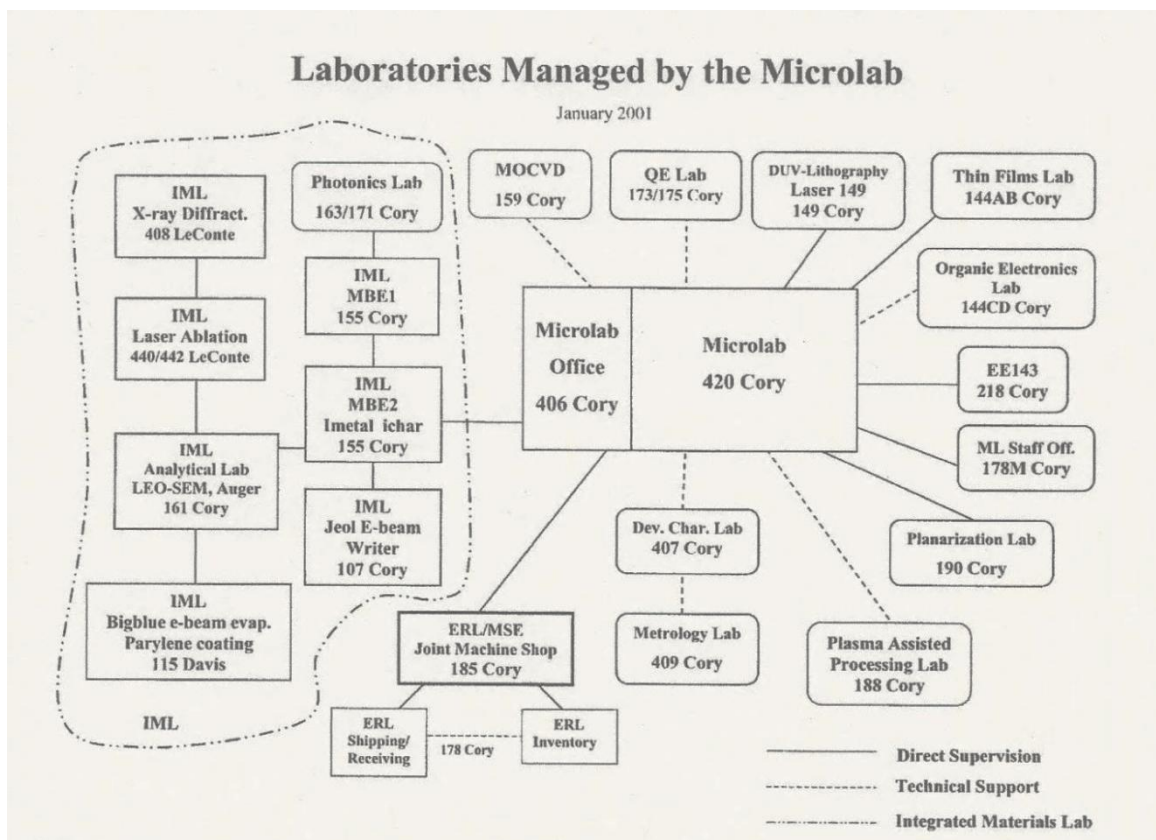

Fig. 23. Satellite labs of the Microlab in 2000.

2. Utilities

Utilities are a part of facilities and are of major concern in any microfabrication lab, which houses equipment for creating submicron devices. Temperature and humidity control is critical for photolithography; cooling water for vacuum pumps/thin film deposition systems, and furnaces; compressed air or nitrogen for solenoid valve operation; chillers for tool temperature control; exhaust fans for chemical sinks and vacuum systems; deionized water for wafer cleaning and chemical processes; and reliable power is critical for all systems. Each utility has to be delivered at a specific pressure, temperature, and purity for safe operation, to avoid damaging research samples and tools, and to prevent system shut downs.

Utilities supplied and maintained by Campus Services were: power, air conditioning, compressed air, industrial water, recirculating cooling water, exhaust fans, and effluent discharge lines. The Microlab maintained its own dedicated utilities, including: deionized water, chemical neutralization system, house nitrogen, house oxygen, clean house-vacuum, and specialty gases. Table II lists the utilities supported by the Campus and by the Microlab, and it serves as glossary for Table IV.

TABLE II
UTILITIES SUPPORTED BY CAMPUS SERVICES AND BY THE MICROLAB

Utilities Supported by Campus Services	
Power	110 V, 208 V, 208 V 3-phase, 220 V, 480 V 3-phase
Air	Compressed air from 2 Cory Hall compressors (in basement) and air dryer
T	Cooling tower on roof of Cory Hall
chws	Chilled house water system, connected to Microlab chillers on roof
cws	Recirculating cooling water, dedicated Microlab loop through the cooling Tower
icw	Industrial cold water, supplied through Cory Hall
s5s	Neslab System 5, supplemental cooling water heat exchanger via Tower
95awn	Vacuum eductors (compressed air) into neutralization tank then into sewer
ihw	Indirect waste line to neutralization tank (95awn)
sewer	From neutralization to Cory Hall sewer line
storm	Cory Hall storm drain
HF-60	Hood fan: fume exhaust fans on the roof of Cory H. (Nos.60, 62, 69, 70, 83, 84)
Utilities Supported by the Microlab	
cyl.gases	Specialty gases (available in the GASES database)
n2	House nitrogen gas from 9000 gal LN vessel owned by the ML, in the backyard
o2	House oxygen gas from 250 liter rented LOX tanks, in the back yard
di	Deionized water, from system on the 5 th floor, 2000 gal holding tank on roof
blimp	Monitoring by BLIMP/RUMS, facilities monitoring system [18, 40]
chiller	Standalone heat exchanger
cleanvac	Clean house vacuum
ln2	Liquid nitrogen from 3000 gal LN vessel owned by the ML
pumps	Vacuum pumps (available in the PUMPS database)
interface	Computer interfacing: GP-IB, PC, RS-232, SECSII
WIS	Walker Interlock System access control feature (enable/disable)
network	Networked for data dumping or tool communications
telephone	Telephone available in room (Microlab managed phone network)

Monitoring of Utilities

Very early on after the opening of the Microlab, it became clear that utilities were not sufficiently reliable to maintain stable operations in the lab. Frequent power failures, cooling water temperature and pressure fluctuations were especially cumbersome, mainly because there was no warning of changes and no way to determine status. Thus, one of the first requests to the computer group from the Microlab was to create a sensors monitoring software system.

The Berkeley Laboratory Infrastructure Monitoring Program, BLIMP, was completed in 1988 and the sensors fully deployed in 1989 [18]. Besides critical utilities, such as DI water level in the holding tank, incoming DI resistivity, nitrogen and oxygen pressure, house vacuum status, compressed air status, lab air conditioner status, cooling water temperature and differential pressure, the program collected silane use-data (from the mass flow meters and controllers). For lab management, email notifications of utilities failures (readings out of spec) were invaluable for quick action and for prevention of major equipment problems. Table III shows the latest redesign of the sensors monitoring software.

TABLE III
RUMS SENSOR STATUS DISPLAY OF CORY HALL UTILITIES



This system monitors critical facilities sensors and specialty gas usage.

- [Sensor Status](#)
- [View all the Graphs](#)
- [Sensor Configuration & Documentation](#)
- [Return to the NanoLab home page](#)

RUMS3 is **on-line** . Last sampling: 4/29/2013 6:22:59 AM

Sensor Name	Description	Low Alarm	High Alarm	Current Value	Units	Status
ICW Pressure	Industrial cold water supply	40	105	95.98	psi	
N2 Pressure	Nitrogen pressure	65	95	79.81	psi	
O2 Pressure	Lab oxygen pressure	18	110	100.46	psi	
Air Compressor	CA 88 air compressor	0.5	1.5	0.38	on/off	
Air Dryer	Compressed air dryer status	0.5	1.5	1	on/off	
Cooling Tower	Cooling tower pump	-1.5	0.5	0.09	on/off	
LN 1 Level	Liquid nitrogen vessel 1 level contact Matheson Dispatch, ph 800-284-0481,*1,*4 (acct# 01036) NanoLab phone #:510-809-8600	75	300	101.07	inches H2O	
LN 2 Level	Liquid nitrogen vessel 2 level	30	110	75.24	inches H2O	
N2 Flow Rate	Nitrogen flow rate	200	1000	567.09	slpm	
O2 Flow Rate	Lab oxygen flow rate	3	30	0.05	slpm	
CHWS Temperature	Chilled house water supply temperature	40	75	54.18	Deg. F	
Ancillary N2 Flow Rate	Nitrogen flow rate to Ancillary Labs	0	500	65.67	slpm	
Cooling Tower Diff Press	Cooling Tower Loop Differential Pressure	10	40	27.99	psi	
Rums Test	Test channel. Please do not delete.	-1	4.26	4.97	Volts / 5	
HMMB N2 Flow Rate	Nitrogen flow rate for HMMB	-300	500	143.56	slpm	

The utilities monitoring software was redesigned, enhanced, and renamed in 2003, and updated again in 2010, with a web-based interface and LabView data analysis. RUMS, the Resource Utilizations Monitoring System, was based on, and retained, many features of BLIMP. It applied the latest computer technology available and also added new capabilities, such as graphs [41].

Utilities Dependencies Database

A huge portion of the work, starting with BLIMP, was compiling an accurate database of an equipment and utilities matrix. Utilities dependencies were determined for each piece of equipment in the Microlab and in its satellites, and documented in the RUMS database. Table IV is a section of the list of equipment depending on utilities maintained by Campus Services; there is a similar table, showing the same for Microlab maintained utilities. Data represents a total of 200 entries, (tools and special rooms,) each depending on some of the 25 utilities needed to maintain the Microlab, in 2006. When a utility failure occurs, the program sends an immediate alarm to assigned staff and users of the machines affected.

TABLE IV
PARTIAL LIST OF EQUIPMENT (LEFT CLOUMN)
DEPENDING ON UTILITIES MAINTAINED BY CAMPUS SERVICES (2006)

	Campus Services Utilities Dependencies															
	Power				Gas		Water					Drains			Fan	
	110	208	208p3	220	480p3	air	T	chws	cws	icw	s5s	95awn	ihw	sewer	storm	Hood Fans
4ptprb in AN2	*															
95awn in 95AWN Cory			*							*		*		*		
acidcart in 420 Cory	*															
afm in 355	*															
aln in 155 Cory			*			*	*									HF-62
amst in 432b	*					*										
aptchrome in R1	*											*		*		HF-83
aptemul in R1	*											*		*		HF-83
asiq in 420-An2	*					*										
asml in GL4	*				*	*	*				*					HF-84
auger in 161 Cory	*	*		*		*										HF-62
autoprobe in 407	*					*										
balance in GL2,Y2	*															
canon in Y1	*					*										HF-84
cape in CY2	*															
cdsem in 420-R2			*		*	*										HF-83
centura in GL1		*	*		*	*	*	*	*	*	*					HF-83
centura-met in 420-GL1			*			*	*	*	*	*	*					HF-83
centura-stri in 420-GL1			*			*	*	*	*	*	*					HF-83
chiller in Cory roof					*		*									
cleanvac in 546					*											
cmp in 190 Cory	*															
computers in 165 Cory	*															
cpa in V3	*		*			*		*	*	*	*	*		*		HF-84
cpd in 432B	*															
cpd2 in 432B Cory	*															
dcl in 407 & 409	*		*			*										
dectalk in 420	*															
dektak in GL3	*															

The latest upgrade of RUMS occurred during and after the move into the new lab in 2010/11. Now utilities are monitored both in the Marvell NanoLab and in Cory Hall, and are listed separately for the two facilities. (See Table III and Table V.)

The only difference is that alarm emails and/or text messages concerning Cory Hall are also sent to the building manager of Cory Hall. When viewed on-line, clicking on the sensor name will create a pop-up window with the line chart of the measured data, as shown in Table V.

TABLE V
RUMS SENSOR STATUS DISPLAY OF NANOLAB UTILITIES (PARTIAL VIEW)
INSET: LINE CHART OF THE MEASURED DATA WITH SPEC LIMITS,
FOR DI WATER RESISTIVITY

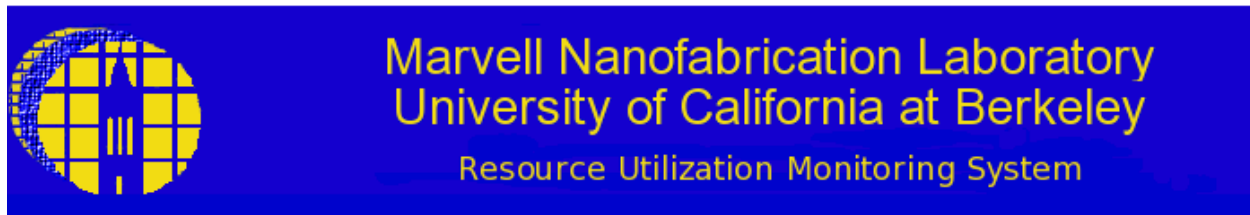

This system monitors critical facilities sensors and specialty gas usage on **RUMS2**.

- [Sensor Status](#)
- [View all the Graphs](#)
- [Sensor Configuration & Documentation](#)
- [Return to the NanoLab home page](#)

RUMS2 is **on-line** . Last sampling: 4/29/2013 2:07:25 PM

Sensor Name	Description	Low Alarm	High Alarm	Current Value	Units	Status
Compressed Air N2 Backup	State of the CDA N2 backup valve (zero indicates no alarm, i.e. N2 backup is not in use).	-0.5	0.5	0	on/off	
Compressed Air Pres						
DI General Alarm						
DI Makeup Flow						
DI Resistivity						
DI Tank Level						
PCW Flow						
PCW General Alarm						

Microlab Sensors Data - Mozilla Firefox

rumS2.eecs.berkeley.edu/graphs/DI_Resistivity.html

MOhm-cm DI_Resistivity - 17.93 MOhm-cm (1:02 PM)

The final resistivity of the DI source.

Campus Utilities

The reliability of utilities delivered by Campus was an overarching issue throughout the history of the Microlab. Keeping the lab operational required constant vigilance; thus, Microlab management invested considerable effort in monitoring status, immediate reporting and following up of problems. Also, preventive measures were put in place wherever possible.

- Frequent power failures were a major problem during the 1990's, until the Campus Electrical Power Distribution project was completed in 2000. New feeds were installed to Substations 1 and 5 and the cogeneration plant was upgraded. Cory Hall is now being fed from Substation 5, (also Sutardja Dai Hall,) next to the Hearst Memorial Mining Bldg.
- Failure of compressed air caused equipment to shut down so often that Microlab staff had to come up with a solution to avoid disaster. Bob Hamilton and his staff implemented a creative measure in 1988: automatic switching to nitrogen when the air pressure dropped below 70 psi. The compressed air situation improved only in 2004, when one of the two compressors in the basement of Cory Hall, was replaced with a new one.
- Keeping the clean rooms at the required temperature and humidity was a constant battle, until the original, poorly designed and under capacity (100 ton) air conditioner, was replaced with two 75-ton chillers, in 1994. It took many complaints and constant campaigning, but Campus Services did come forward with the solution. (Fig. 24.)



Fig. 24. Lobbying for a new air conditioning system.
Visit of high-level staff from Campus Services, in 1993, with Johnny Torrez, Assistant Vice Chancellor for Campus Services in the middle.

- Even before the Microlab became crowded with equipment, cooling water capacity had been a problem. Insufficient recirculating cooling water reports began in 1988, when construction of the 5th floor of Cory Hall caused major disruptions in Microlab operations. The recirculating water loop was poorly designed when moved to the roof and had to be re-plumbed immediately after the construction. Campus Services, after a series of requests, assumed responsibility for the rework.

By 1992 insufficient and fluctuating industrial cold water pressure became a problem, which was never resolved fully, only ameliorated somewhat by strategic re-plumbing inside the lab. Cooling water capacity continued to plague operations, until the Microlab created a new loop with a stand-alone chiller, in 2003.

- Custodial services were used only for trash removal and floor cleaning inside the lab. The Microlab had its own, dedicated vacuum cleaner and custodians were trained by lab staff in what they were supposed to do – and not do. Even this minimal service deteriorated over the years.

Soon after the opening, Microlab staff organized lab member Clean Fests, to straighten up work areas and scrub down equipment and walls. This became a twice a year routine, which kept the lab generally in good shape. Marilyn Kushner was the lead in this effort.

Keeping Campus utilities within specifications required by lab operations was a significant part of the job of the Microlab's maintenance staff. Problems had to be reported and followed up through the EECS facilities' office. Fortunately, the Microlab had a major supporter in dealing with Campus Services, in Wil Zeilinger, Department Engineer, until his retirement in 1991, and Scott McNally, at first as Stationary Engineer for Campus Services and then as Director of Space Planning and Facilities of EECS, starting 2001.

Other Factors – Neighborhood Construction Projects

The immediate neighborhood of the Microlab, the NE corner of the UC Berkeley campus, went through significant changes during the 28 years the lab existed. Soon after the opening ceremony, construction of the 5th floor of Cory Hall began. This was followed by other major projects, listed in Table VI.

Construction projects impacted Microlab operations in several ways.

- Access routes to Cory Hall were severely congested and limited. This was especially distressing during the renovation and seismic retrofit of the Hearst Memorial Mining Building (HMMB), all of 35 feet away from Cory Hall.
- Liquid nitrogen, oxygen and specialty gas deliveries had to be rerouted, which lasted close to ten years during the renovation of the HMMB and the construction of Stanley Hall.

- Construction vehicles created a large amount of traffic, noise, dust, and vibration around Cory Hall, which is located on the corner of two arteries, Hearst Avenue and Gayley Road. See Fig. 23. It was difficult to maintain a Class 100 clean room environment when dust and dirt are carried into the building from all sides.
- Campus utilities lines were in constant danger of being disrupted; this happened often, either by necessity or by accident. The power upgrade and communications trunk lines installation projects required trenches across Campus, including one in the narrow path between HMMB and Cory Hall. Microlab management developed a habit to look out, when walking across campus, for signs of digging and other disturbances, and inquired what the activity was for. This afforded early alerts to support staff and lab members, of possible disturbances and/or shut downs.

TABLE VI
CONSTRUCTION PROJECTS IN THE NEIGHBORHOOD OF THE MICROLAB (1983-2009)

1983-1985	Construction of the 5th floor of Cory Hall (above the Microlab)
1992-1994	Soda Hall construction
1995-2000	Campus power upgrade
1998-2002	HMMB renovation and seismic retrofit
2003-2007	Stanley Hall
2004	CITRIS site demolition
2006-2009	Sutardja Dai Hall construction

The first major upheaval was the addition of the 5th floor to Cory Hall. This construction, completed in 1985, creating the CAD/CAM Facility, was the second phase (the Microlab being the first) of the EECS/ERL five-year Plan for Microelectronics and Computer-Aided Design, 1981-86. [5]

For two years the Microlab had to endure construction above its ceiling, insertion of support columns into the lab area, rerouting of utilities, such as power, water and gas lines, and moving the DI water holding tank to the new roof. It was a consolation that the design of the 5th floor improved considerably the facade of boxy Cory Hall and included stylized integrated circuits under the newly added arches. It did not matter that the general public thought these were native Indian signs – those in the know felt an immediate affinity to the fresh new look. (Fig. 25.)

The Microlab was located on the 4th floor of Cory Hall, facing Hearst Avenue.



Fig. 25. Cory Hall from the corner of Hearst Avenue and Gayley Road (1987).

Next on the agenda of the Department (and Campus) was construction of a new building for the Computer Sciences Division of EECS. This was considerably less painful for the Microlab than the construction of the 5th floor of Cory Hall. Traffic, dust, and dirt on Hearst Avenue, were the major culprits, along with the occasional power interruptions. Microlab staff enjoyed a prime view of the construction, as the new building was growing out of the ground, at an amazingly rapid rate, catty-corner across from Cory Hall, two buildings down on Hearst Avenue. Soda Hall had an added attraction: it relieved space pressures in Cory Hall – for a while. Fig. 26 and 27 show Soda Hall under construction and as completed.



Soda Hall Construction, viewed from the Microlab's western office window (406 Cory)

Fig. 26. (left) Soda Hall in February 1993.

Fig. 27. (below) Soda Hall, completed in 1994, on the corner of Hearst and Le Roy Avenues.



Of all the neighborhood construction projects during the life of the Microlab, the renovation and seismic retrofit of the Hearst Memorial Mining Building was the longest and the most painful. Because it is a historical building, renovation and restoration had to be carefully planned; seismic isolation was provided by lifting the building up on stilts and placing 120 isolation pucks under the basement. A moat was created around the foundation to allow space for movement during an earthquake. The project lasted five years. The final result can be seen in Fig. 29. Major issues were:

- HMMB was completely decanted, which meant that equipment from the IML joint lab had to be dispersed into Le Conte Hall, Cory Hall, and Davis Hall.
- The backside of Cory Hall was completely closed off, no access of any kind.
- All windows and doors on the South side of Cory Hall were padded and sealed off completely. Regardless, dust was settling inside, everywhere, and the noise was so overwhelming sometimes that discussions had to stop until the noise abated.
- Because the back area of Cory Hall was closed to access, liquid nitrogen (LN), and all other shipped items, had to be delivered from Hearst Avenue. A new, thermally isolated feed line and valve station had to be built by the project, to allow filling of the LN vessels from Hearst Avenue. The huge LN tank trucks caused traffic problems; thus, delivery had to be scheduled into off hours, and required two people instead of just the driver. This situation lasted for almost 10 years through the completion of Stanley Hall.
- Renovation plans included moving the Microlab's LN vessels to make room for a mechanical building for HMMB. (Fig. 28.) Moving the vessels required rebuilding the concrete pads to meet current code. At least this disturbance gave the Microlab the opportunity to have the site prepared for a larger vessel, which the lab purchased (2002), to enable less frequent deliveries for fill-up, (once a week,) and to plan for the new lab.



Fig. 28. Microlab LN vessels (3000 and 9000 gallons) and specialty gases service area, wedged between Cory Hall and HMMB's mechanical service building.



Fig. 29. Renovated Hearst Memorial Mining Building, with Cory Hall's signature arch showing.

The final, and welcome, construction project during the history of the Microlab, was a new engineering building, which included a new lab. The Center for Information Technology Research in the Interest of Society, CITRIS, was a State of California initiated research program, formed in 2001. Because of the requirement of matching funds, which were not in place fully by the start, the building project was divided into Phase I, demolition (2004) and Phase II, construction (2006-2009), with a year hiatus between the phases. (See Fig. 30-32.)

The new building, with its south side abutting Davis Hall, was squeezed in masterfully between Cory Hall (48 feet away) and the old Naval Architecture Building. The main building, called CITRIS Headquarters, is seven stories high and has a five story wing, along Hearst Avenue, containing the lab. http://citrisc.uc.org/about/headquarters/marvel_labs. (See Fig. 33-38.)

The wing was a creative solution to meet the code requirements which do not allow offices to be located above a lab with a hazard classification of H6 (toxics allowed). Thus, a two-story laboratory was designed, with mechanical systems in the interstitial space, also below the 3rd floor (Class 100) and above the 5th floor (Class 1000). Nitrogen gas is supplied from the vessels outside Cory Hall.

Microlab staff were able to observe from the 406 Cory Hall office windows, every phase during the long drawn out demolition and construction. The view inspired hope for the lab's existence for the next 30 years and five years of waiting gave management ample time for planning.



Fig. 30. (left) Construction of CITRIS Headquarters, seen from 406 Cory Hall (2007). (Before the structure blocked the Bay view.)



Fig. 31. (below) Sub-fab construction of the laboratory wing of the CITRIS building (2006).

The CITRIS Headquarters building was made possible through a combination of public and private funds. It is named Sutardja Dai Hall in recognition of the contribution made by brothers Sehat and Pantas Sutardja, and of Weili Dai, the three co-founders of Marvell Technology Group, an international semiconductor company based in Santa Clara. All three are UC Berkeley alumni: the brothers hold Ph.D. degrees in Electrical Engineering and Computer Sciences, and Dai, who is married to Sehat Sutardja, has a B.S. degree in computer science. The new lab was named the Marvell NanoLab.



Fig. 32. Microlab staff, soon to become Marvell NanoLab staff, watching from the roof of Cory Hall, the “Topping Out” ceremony of the CITRIS Headquarters building (March 2007).



Fig. 33. Marvell NanoLab wing; the NW corner includes a clean stairwell between the two lab floors.



Fig. 34. West facade of the NanoLab (with view of the Golden Gate bridge from the fifth floor window).



Fig. 35. Partial view of the NanoLab wing and the main part of Sutardja Dai Hall (SDH), as seen from Hearst Avenue.



Fig. 36. NanoLab as viewed from the plaza between Blum Hall and SDH.



Fig. 37. North entrance to Sutardja Dai Hall from Hearst Avenue; Marvell NanoLab on left, CITRIS Headquarters in center, Blum Hall (formerly Naval Architecture) on right.



Fig. 38. The A. Richard Newton Bridge between Cory Hall (left) and SDH (right), viewed from Hearst Avenue.

3. Equipment

The Microlab started in 1983 with the 67 pieces of equipment, listed in Table I, on page 9 of this report. New tools installed at that time enabled automatic handling of 4-inch diameter silicon wafers. These were the wafer stepper, photoresist dispenser and developer, and furnaces. 2-inch and partial wafers were processed through the legacy tools from the “old lab”. Four years later, in 1987, the equipment list contained 116 pieces. By this time the lab was supporting several different CMOS, III-V compounds, Josephson junction superconductor, and various other types of processes. Table VII shows the equipment list in 1993 [28].

TABLE VII
MICROLAB EQUIPMENT LIST IN 1993

MICROLAB EQUIPMENT	
MASK MAKING	EQUIPMENT FOR SUPERCONDUCTORS
GCA 3600 pattern generator	Exciton cluster tool (modified Veeco)
APT chrome mask developer	Davis and Wilder evaporator
APT emulsion mask developer	Gartek 3-target sputterer with ESCA
Ultratech mask duplicator	Semi-Group plasma/RIE system
	S-gun sputtering system
	Dektak profilometer
PHOTOLITHOGRAPHY	PLASMA SYSTEMS
GCA 6200 10× (4") wafer stepper (I-line)	2 Lam Autotech systems (4")
GCA 6200 10× (4") wafer stepper (G-line)	Lam 690 aluminum etcher
Canon 4× wafer stepper	Lam Rainbow etcher
Kasper contact aligner	Technics plasma etching system
VWR bake oven	2 Technics plasma deposition systems
Headway photoresist spinner	Technics Microetch PR remover
4" wafer track photoresist application system	Tegal plasma etcher (4")
SCT photoresist film thickness monitor	Plasma-Therm RIE system
MTI 4" developer/stripper	
MTI Flexifab PR developer system	
	ANALYTICAL EQUIPMENT
ADVANCED PHOTOLITHOGRAPHY	5 high-power microscopes
Microstepper (modified Ultratech)	(1 with color TV monitor, 1 with 35 mm camera)
Cymer Excimer laser	Reichert Polylite microscope
Continuum YAG laser	Vickers image-shearing microscope for line width
HP diode array spectrophotometer	Canon video camera and recording system
Perkin Elmer development rate monitor	Nanometrics Nanoline (line width)
Silylation system	Nanometrics Nanospec AFT (film thickness)
Analect FTIR spectrophotometer	Nanometrics deep UV microspectrophotometer
Big Sky laser beam intensity profiling system	Nanometrics Cwikscan II SEM with Codonics printout
	Gaertner ellipsometer with HP computer control
WAFER CLEANING	Tencor Alpha-Step 200 automatic profilometer
12 Semifab wet process stations	Tencor Sonogage rt2 resistivity meter
DI water: Continental Water RO system	Prometrix OmniMap resistivity mapping system
2 fluorocarbon 4" spin dryers	Signatone manual 4-point probe with HP instrumentation
	Signatone C-V probe station with HP computer control
THERMAL PROCESSING AND CVD	Signatone I-V probe station with HP 4145 analyzer
Tylan/Tytan-II computer-controlled furnaces	Scientech electronic balance
12 general-purpose tubes	VG Instruments residual gas analyzer
7 LPCVD tubes	Ion Systems static controller
Lindberg furnaces, 4 tubes for 2" wafers	
2 AG heatpulse 210 RTA (rapid thermal annealer)	COMPUTERS
for III-V compounds and silicon	Sun 4/280 file server with 72 MB RAM and 2.8 GB disk
Liquid phase epitaxy system	SUN SPARC 1, SUN SPARC 2
	10 Sun 3s
THIN-FILM SYSTEMS	7 NCD X terminals
CPA 3-target sputtering system	32 ASCII terminals
Hummer sputterer for gold coating SEM samples	Taurus automated switching system
MRC sputterer for zinc oxide	Acurex data acquisition system
MRC magneton sputterer for PZT	TCP/IP Ethernet and NFS Networking
Perkin-Elmer Randex 3-target sputterer	UNIX operating system
Varian NRC WE-04 evaporator	INGRES database system
Varian 936 leak detector	WAND/STAFF lab management software (BCIMS)
Veeco 401 evaporator	KIC, VEM, MAGIC, SAMPLE, SUPREM, SPICE, BIPS,
Veeco Microetch ion milling system	and other design and simulation software
Ultek evaporator	
PACKAGING	
Disco wafer saw	
Westbond ultrasonic bonder	

By the middle of the 1990's requests from device and MEMS PIs to process 6" wafers began to mount; thus, the Microlab embarked on a 6-year, in-house project to upgrade silicon processing tools to handle 6-inch wafers. At the same time 4-inch (and partial wafers) processing capability had to be retained, as 40% of the lab members had no need for larger wafer sizes (1995/96).

About half of the tools in the Microlab were modified to handle 6" wafers. Eight new/refurbished tools were added, three of which were installed in the newly constructed Planarization and Thin Films satellite labs. Eighty tools became dual mode, both 6" and 4" handling capability, 28 remained 4" only. A detailed report on the 6" upgrade project can be seen in Ref. 43.

The equipment list, 139 tools – just before moving to the NanoLab – is shown in Table VIII. The names on the left, in each column, are the computer login names of the tools. Login names were used when enabling and disabling tools for processing, for problem reporting, for accounting, and for general on-line record keeping.

TABLE VIII
MICROLAB EQUIPMENT IN 2010

4ptprb	4 point resistivity probe
aln	Al. nitride sputtering AMS-2003
amst	AMST molecular vapor deposition
aptchrome	APT chrome mask developer
aptemul	APT emulsion mask developer
asiq	Tencor AS500 profilometer
asml	ASM Lithography 5500/90 stepper
autoprobe	Electroglass autoprobe
barrelasher	Tegal barrel asher
canon	Canon 4X wafer stepper
centura	Centura deep silicon etch
cmp	Strausbaugh CMP
computers	computer servers and terminals
cpa	CPA three-target sputterer
cpd	Critical point dryer
cpd2	Tousimis critical point dryer
diebonder	MEI 779 die bonder
dw	Davis & Wilder evaporator
edwards	Edwards sputter system
edwardseb3	Edwards 306 E-beam system
filmtek	Film thickness measure. sys.
flexus	Tencor FleXus stress gauge
flipchip	Suss FC150 flip chip bonder
gartek	Gartek sputterer
gcapg	GCA 3600 pattern generator
gcaws2	GCA G-line 10X wafer stepper
gcaws6	GCA 8500 5X I-line wafer stepper
handry	Hand dryer in lobby
heatpulse1	Rapid thermal annealer for Si
heatpulse2	Rapid thermal annealer for GaAs
heatpulse3	AG 610, 6" annealer for silicides
heatpulse4	AG 610, 6" annealer for silicon
hfvapor	Idonus HF Vapor Etcher
hld	Edwards 600 helium leak detector
hummer	gold evaporator for SEM samples
iondep	Ion Beam Systems dep.system
ionmill	Veeco ion mill
irscope	infrared microscope
iv	I-V probe station (AN3)
jeol107	JEOL 6400 e-beam writer
kruss	Kruss contact angle analyzer
ksaligner	Karl Suss mask/wafer-bond aligner
ksbonder	KS wafer/ wafer bonder
lam1	Lam plasma etcher for Si-nitride
lam2	Lam plasma etcher for SiO2
lam3	Lam 690 aluminum etcher
lam4	Lam Research Rainbow 4400
lam5	Lam 9400 TCP poly-Si etcher
lapper	Solid State M. lapper
leo	Leo scanning electron microscope
linewidth	Leitz line width measuring sys.
maskcopy	Ultratech mask copier
matrix	Matrix 106 photoresist remover
memscope	MEMS microscope
microscope	all microscopes
nanoduv	DUV spectrophotometer
nanospec	film thickness measuring system
nanox	GaAs oxidation and nanotube

novellus	Novellus MI2 sputterer
nrc	NRC evaporator
oven	all bake ovens
oxford	Oxford Plasmalab System 100
oxford2	Oxford Plasmalab 80 PECVD
p5000	Applied Materials P5000
pyrlene	Specialty Coating Systems
picosun	Picosun R150 atomic layer dep.
plotter	Hewlett Packard wide plotter
polisher	South Bay Tech. polisher
pqecr	Plasma Quest PECV Deposition
primeoven	Yield Eng. Systems YES-5 oven
ptherm	Plasmatherm reactive ion etcher
quintel	Q4000-6IR contact printer
randex	Randex sputtering system
reichert	Reichert inspection microscope
rs100	KLA Tencor resistivity mapper
rtcvd	rapid thermal CVD
rudolph	Rudolph AutoEL-III ellipsometer
sca	Semitest surface charge analyzer
sealer	Impulse bag sealer
semi	Semigroup plasma etcher
sink12	sink in room R1
sink3	TMAH and KOH etch in GL2
sink4	sink in room Y1
sink432a	sink in room 432a
sink432c	fumehood sink (in 432C)
sink5	sink in Y2
sink6	sink in V1
sink7	left sink in V2
sink8	right sink in V2
sink9	sink in V3
sinkcmp	CMP wet-sink
sinkplate	hood and sink in old lab, 432D
sopra	variable angle/frequency ellips.
spinner1	Headway spinner in room Y1
spinner3	Cee spinner
srdsink5	Verteq spin/rinser/dryer
srdsink6	Verteq spin/rinser/dryer
srdsink8	Verteq spin/rinser/dryer
sts	Surface Technology ICP Etcher
svgcoat1	SVG 8626/36 PR coater /baker
svgcoat2	SVG 8626/36 photoresist coater
svgcoat3	SVG 8626

svgcoat6	SVG8800 6" photoresist coater
svgdev	SVG 8632 CTD PR developer
svgdev6	SVG8800 6" developer
technics-c	Technics VLSI plasma etch
tensiometer	Sigma 701 surface tension m.
topgun	multi-gun sputtering system
tylan5	Tylan furnace tube #5
tylan6	Tylan furnace tube #6
tylan7	Tylan furnace tube #7
tylan8	Tylan furnace tube #8
tystar1	Tystar 6" Wet/Dry Oxidation
tystar10	Tystar LPCVD doped poly-Si
tystar11	. LPCVD doped LTO, MOS
tystar12	Tystar LPCVD doped LTO
tystar13	Tystar 6" POCL3 doping
tystar14	.6" solid-source boron doping
tystar15	6" LPCVD silicon carbide
tystar16	. 6" LPCVD doped poly-Si
tystar17	LPCVD low stress nitride
tystar18	Tystar 6" MOS sinter
tystar19	Tystar LPCVD Si/Ge, MOS
tystar2	Tystar 6" wet/dry oxidation
tystar20	Si/Ge LPCVD for MEMS
tystar3	Tystar 6" wet/dry oxidation
tystar4	Tystar 6" wet/dry oxidation
tystar9	Tystar LPCVD Si-nitride/HTO
ultek	E-Beam evaporator, 3-hearth
uvbake	Fusion photo-stabilization sys.
uvscope	Leica I-line microscope
v401	Veeco 401 vacuum system
vacoven	YES vacuum oven
wafersaw	wafer dicing saw
westbond	7400B Al wire bonder
westbond2	West Bond Au wire bonder
wyko	Wyko optical profilometer
xdif	X-ray diffractometer
xetch	xenon difluoride bulk silicon etch

Equipment Access Control

One of the key elements of running a multidisciplinary laboratory is to control access to the equipment. Another is to keep detailed and accurate records of use, for tool maintenance and for accounting purposes. Both access control and record keeping were accomplished in the Microlab with BCIMS, the Berkeley Computer-Integrated Manufacturing System, a management information system created specifically for the Microlab by researchers in EECS and IEOR, BCIMS, to be described in detail in a later section, included a combination of software and hardware applications, which allowed overall control of equipment management.

Equipment access control was accomplished by physically rendering a tool unusable, unless it was enabled through the lab computer. The Microlab's first equipment control system was designed in 1984 by Alex Para, staff engineer in EECS. It employed a Taurus switching matrix computer and individual, in-house built, on/off boxes at each tool. The boxes were hard wired, using telephone cabling, to the Taurus computer, and the Taurus to the main lab computer server (a VAX at that time). The lab computer, named Merlin, (leave it to the computer people to come up with imaginative names,) had several terminals in each room and service area, with an equipment enabling menu driven interface, called WAND. (Merlin waved his wand and, magically, the tool was enabled for use.) Merlin checked the validity of the user's account and whether the person was qualified to use the machine or not. Also, it started to count the minutes the tool was enabled and reported the total time to the accounting module for charging.

Once the enable signal was sent, the Taurus computer directed it to the appropriate tool control box, which energized a solenoid valve or relay, depending on the mode by which the tool was rendered unusable. Solenoid valves controlled gases, vacuum, or cooling water; relays controlled lights, key boards, or other electronic parts, (but rarely the main power), which were necessary to operate the tool. After the end of the work, the researcher disabled the tool by the same method and was prompted for a problem report, if any, or a comment. Fig. 39 is the equipment enable page of the WAND.

```
silicon22 MICROLAB: voros
CATEGORIES(space)          TASKS(space).....
* ALARM -> USE PULL-DOWN STATION!!! . d Disable equipment .
c Chemicals and Materials . ==>e Enable equipment .
==>e Equipment . f FAULTS .
E Equipment Communication . E Read enable message .
g General Purpose . n Equipment names .
h Help . o Read old equipment logs .
i Info. About Lab Members and Fees . p Problems and comments .
l Lab Manual and Your Lab Notes . q Qualified members list .
m Mail and Messages . r Recharge equipment .
p Process Logs . s Show problem status board .
r Reservations . t TCA clean of tylan tube .
s Sign Out of Lab . T Turn off TCA cleaning .
S Safety, Trouble & Prevention . w What is currently enabled .
v Visitors . W Show your current equipment only .
HELP          TASKS IN PROGRESS(%)
- Use "s" to SIGN OUT
- Enter character next to item
- SPACE moves between main menus
- Use ? (and !) for help info
Equipment name to enable: randex
```

Fig. 39. Equipment enable page of the WAND.

Equipment and Utilities Maintenance

The most important function of the Microlab was to provide a working research environment for the lab members (i. e. graduate student users). This meant that equipment had to be up and running, preferably most of the time, and had to generate standard processes reliably. The only way the lab could support itself was by having researchers utilize the facility; then research grants could be charged for the use. Income was a direct function of equipment up-time, a concept repeatedly emphasized to, and clearly understood, by staff.

The term “Equipment Maintenance” involved several activities:

1. Repair after break-down; call for process testing (done by process staff).
2. Preventive maintenance and spare parts ordering.
3. Utilities monitoring and maintenance.
4. Improvements, upgrades.
5. Record keeping.

Each piece of equipment, each utility and each satellite lab was assigned to individual staff members, with back-up secondary assignments. (Table IX shows equipment maintenance assignments.) Thus, each tool was “owned” by one person, who was the first responder to a problem report and **repaired** the tool. When done he submitted a “fix” report, indicating that the tool is ready for process testing. Equipment technicians also replied to questions by users concerning their tools. (In case the “owner” was out the secondary assignment became effective.) If the owner needed help in solving a problem, the supervisor assigned another technician or engineer who had the appropriate skill set for the repair. This occurred mostly in the case of electronic sub-assemblies and pump repairs. Special repair requests were handled by the supervisor who could change tool repair priorities.

The job classification that best suited the lab’s needs was the Development Technician series, which requires a broad range of skills, encompassing mechanical, electrical, electronic repair capability. Considering the difference between the details of lab support – many different types of tools and legacy equipment – and those of industrial production support, where technicians are much more specialized on a single or just a few tools, Microlab management preferred to hire at lower skill levels and train in-house. This also gave technicians an opportunity to develop their career at the Microlab. Of the nine staff listed in Table IX, seven developed to engineering levels during their tenure there.

TABLE IX
EQUIPMENT MAINTENANCE ASSIGNMENTS

Alan Briggs is responsible for the following equipment:				
parylene	misc	srdsink5	hepa	fancoil
95awn	polisher	srdsink6	lapper	chiller
balance	rodi	rdsink8	handry	facilities
safety	static	sinkcmp	sinkplate	spinner1
sealer	sink432a	sink3-12	sink432c	
	utilities	acleaner		
Joseph Donnelly is responsible for the following equipment:				
iondep	cpa	novellus	ultek	
aln	hld	p5000	xetch	
cmp	ionmill	randex		
Phill Guillory is responsible for the following equipment:				
adt2	dcl	ee143	lnfill	phones
				WIS
rooms145,147,149,151,155,159,161,167,173,185,188, 190,218,317,411				

Mike Linan is responsible for the following equipment:			
adt2	hogen	pumps	gases
David Lo is responsible for the following equipment:			
aptchrome	heatpulse3	primeoven	svgcoat6
aptemul	heatpulse4	ptherm	svgdev
barrelasher	matrix	svgcoat1	svgdev6
heatpulse1	oxford	svgcoat2	uvbake
heatpulse2	oxford2	svgcoat3	
Brian McNeil is responsible for the following equipment:			
amst	diebonder	nanox	wafersaw
cleanvac	gas-inven	pumps	westbond
cpd	gases	truck	westbond2
cpd2	hogen	vacoven	
Jay Morford is responsible for the following equipment:			
lam2	lam5	lam1	technics-c
lam4	edwards	lam3	v401
lam4	edwardseb3	nrc	
lam5	hfvapor	pqecr	
Danny Pestal is responsible for the following equipment:			
tylan5-8	tystar1-20	4ptprb	probe145-2
autoprobe	flipchip	rs100	irscope
rums	kruss	tensiometer	ksaligner/ba6
Evan Stateler is responsible for the following equipment:			
crestec	centura-stri	jeol107	reichert
rtcvd	centura	leo	rudolph
xdif	filmtex	linewidth	sca
afm2	flexus	memscope	sopra
asiq	gcapg	microscope	sts
asml	gcaws2	nanoduv	uvscope
canon	gcaws6	nanospec	wyko
centura-met	hummer	picosun	
centura-mxp	iv	quintel	

Equipment maintenance requirements changed substantially during the life of the Microlab. Semiconductor processing tools became more sophisticated every year, while the shrinking of critical dimensions required tighter and tighter performance specifications and more powerful measurement instrumentation. Here is where developing a long term and stable support staff paid off. With each new (usually a refurbished used) tool support staff was able to learn operation and maintenance, beginning with installation. Microlab staff took the opportunity to learn as much as possible from the manufacturer's engineers who assisted with the start-up. Management requested that staff training be included in the purchase price, if the tool came in through a PI grant, or paid for training, out of operating funds. The Microlab could not afford to purchase expensive maintenance contracts; thus, staff training became an indispensable part of operations.

Equipment maintenance changed also in other ways. As the semiconductor industry in Silicon Valley developed in new directions and wafer manufacturing moved off-shore, service companies began to offer repair services at more reasonable prices and with better response time.

Vacuum pump repair was one of those services which became attractive to utilize. Also, with the advent of LPCVD and plasma processes, dry pumps became ubiquitous. These are difficult to service in-house, and were sent out from the beginning. Thus, when James Parrish, the lab's long-term pump maintenance technician retired in 2004, management made a decision to switch pump repair and refurbishing to an outside service. At the closing of the Microlab the PUMPS database listed 141 items, a mix of wet pumps, dry pumps, booster pumps, cryogenic pumps and turbo pumps. Pump management was a full time activity for one technician, often with the supervisor's help.

Equipment repair priorities were established, almost automatically, by demand. High-use, single process tools were fixed first, such as wafer steppers, LPCVD furnaces, and deep silicon etch plasma systems. Technicians learned quickly which tools were on top of the list; if more than one tool needed immediate attention, the supervisor assigned priorities. This was also true in case of utility failures.

Each tool had a **preventive maintenance** schedule, determined mostly by operational experience in the lab. Maintenance schedules suggested by the equipment manufacturer for industrial use were applicable in the type of service needed but not in frequency. The calendar program of BCIMS sent mail to technicians when maintenance was due and also posted it to the on-line maintenance board. Ordering spare parts was also the responsibility of the tool "owner". Table X shows an example page from the Maintenance Calendar of a technician.

TABLE X
SAMPLE PAGE FROM THE MAINTENANCE CALENDAR (2011)

Recipient	Subject	Send When	Interval	Post	Memo
linan	asml	15-may-2011	1 year	y	Submit order for new laser mix cylind
linan	asml	15-jun-2011	1 year	y	Change asml laser mix in new cylinder
linan	aln	27-aug-2011	1 year	n	Order replacement diaphragm for aln
linan	safety	28-may-2011	3 months	n	Discharge and recharge NiCd on Brenton
linan	tystar17	15-apr-2011	1 year	n	Check the edwards exhaust trap of t17
linan	safety	13-oct-2011	1 year	y	Send RKI Eagle ES-23AH PH3 meter calib
linan	tystarbank4	10-apr-2011	3 months	y	check pump exhaust filters for fowling
linan	cpd	16-nov-2011	1 year	n	Replace cpd filters
linan	safet	1-may-2011	1 year	y	Calibrate and test HAZMAT
linan	safety	7-jun-2011	1 year	y	Check HAZMAT for proper operation
linan	safety	9-apr-2011	6 months	y	Confirm operation of RKI gas detector
linan	safety	1-dec-2011	1 year	y	Annual Draeger system check and cal.
linan	safety	1-jan-2012	1 year	y	Check and update Gas Safety Binders
linan	randex	1-sep-2011	6 months	y	Check randex chamber, clean if needed

The Maintenance Calendar module of BCIMS was created in 1992 and was utilized extensively throughout the life of the Microlab. Process related maintenance tasks, such as tool accuracy tests and process monitoring, were executed by the process staff, who also received calendar reminders. Table XI shows representative examples of maintenance task executed by process staff.

TABLE XI
EXAMPLES OF MAINTENECE TASKS EXECUTED BY PROCESS STAFF

Recipient	Subject	Send When	Interval	Memo
marilyn	reichert	17-mar-2011	2 months	Clean reichert camera syst
marilyn	misc	14-apr-2011	2 months	Clean and replace wfr wands
marilyn	VWR oven	20-jun-2011	6 months	Clean VWR oven cassettes
marilyn	vickers	14-mar-2011	3 months	Check vickers calibration
marilyn	nanospec	17-mar-2011	1 month	Calibrate the nanospec
marilyn	gcapg	11-mar-2011	1 month	Stage motion tolerancetests
marilyn	gcapg	22-mar-2011	1 month	Angles and alignment tests
marilyn	gcapg	22-mar-2011	1 month	Run CD mask
marilyn	gcaws2	10-may-2011	3 months	Run stage accuracy test
marilyn	gcaws6	11-jun-2011	6 months	Backup data on hard disk
marilyn	gcaws6	11-jun-2011	6 months	Verify accurate stage motn.
marilyn	gcaws, gcapg	19-may-2011	90 days	Empty waste oil gcapg,gcaws
marilyn	gcapg	5-may-2011	6 months	Vendor stage maint.
marilyn	bonder	7-mar-2011	1 month	Oil bottom of bonder
marilyn	gcapg	9-mar-2011	25 days	Change Hg lamp on gcapg
marilyn	gcaws6	5-mar-2011	7 days	Oil the wafer stepper

Microlab maintained utilities, shown in the bottom part of Table II (page 23), fell in the same category as equipment. Maintenance of these required at least one FTE, with the supervisor assisting; pumps and gases were handled by additional staff.

Utilities maintenance became an important staff activity early on, when it became clear that Campus support was insufficient. Besides monitoring and the preventive measures taken, as discussed in the previous, 2. *Utilities* section, Microlab staff was responsible for managing in-house utilities, listed in the lower half of Table II. Routine maintenance was included in the Maintenance Calendar and posted on the on-line Maintenance Board, to be reviewed by the supervisor for completion. Several items required special handling.

- The reverse osmosis deionization system (rodi) was serviced by an outside firm, with resin beds and membranes replacements on call. Once a year, Microlab staff executed a thorough bacterial cleaning (sterilization), by flushing the system with a diluted quaternary ammonium salt solution. Beginning in 2005 sterilization maintenance was driven by analytical test data, significantly reducing the frequency of lab week-end shut downs.
- Drains inside lab were a major headache from the start. The “vacuum eductor” system applied at all sinks, utilized compressed air to create a Venturi effect to educt reject-water. When the building compressors failed, or underperformed, water was not removed from the bottom of the cleaning sinks and created a flood. As mentioned earlier, compressor failures were common, creating floods in the Microlab; thus, “Emergency flood procedures” were posted on the WAND. Instructions included shutting off valves and cleaning up afterwards (1992). Two corrective actions helped to reduce the frequency of floods: compressed air was delivered more reliably after one of the compressors in the basement was replaced (2004) and re-plumbing the sinks to gravity drains, in 2006.

Although the flood situation improved considerably, gravity drains had their own problems: long lines, with insufficient pitch, and sagging. The lab had only one floor penetration, in the NE corner (VLSI service chase) for the main drain pipe, leading into the neutralization system in the basement. Thus, sink1, the farthest point away from the main drain, had to have a 160 feet long drain pipe. There was not enough slope to create a sufficiently fast flow, and stagnant liquid stayed in the pipes. Still, the gravity system was a great improvement over the “vacuum eductors”.

- After about 20 years of use, the original nylon/tygon/teflon tubing used for non-critical water and gas connections began to fail. (All critical gas and water lines were made in stainless steel.) The plastic material began to harden and crack, and developed leaks and/or popped off fittings. Starting in the mid 2000’s the original plastic tubing was gradually replaced on most machines.
Cylinder gases were automatically shut off after use; however, nitrogen gas was ubiquitous all over the lab and often used in pneumatic applications. The occasional power failure, during which all equipment became quiet, including air conditioning, provided a good opportunity to find nitrogen leaks. Following the hissing sounds, staff was able to identify the location of nitrogen leaks, repair loose fittings and replace cracked tubes.
- The Microlab had established a compressed gas cylinder handling policy, at the outset: gas cylinders were to be exchanged only by staff. Management of compressed gas cylinders was handled first by technical staff and later, when the number of cylinders in use grew to over 50, purchasing staff took over. In 1992 the GASES database was created and was used, with enhancements added, until the closing of the lab. By that time, processes required 46 different types of gases, 95 cylinders were online (in use), and 60 cylinders were spare stock. Liquid nitrogen and oxygen refill deliveries were also handled by purchasing staff.

```

                                PROJECTS
RECIPIENT (space).....FUNCTION (space).....
.==>u Unassigned Projects      .   r read current joblist
.   a Alan Briggs              .   e edit current joblist
.   B Brian McNeil            .   p print current joblist
.   d Danny Pestal            .   P print ALL joblists
.   e Evan Stateler           .   E equipment status board
.   j Joe Donnelly             .   a read archived joblist
.   l Mike Linan              .
.   L David Lo                .
.   m Jay Morford             .
.   M A. Michael Martin       .
.   p Phillip Guillory        .
.....
HELP                                TASKS IN PROGRESS(%)
- Enter character next to item
- Only select from menu in box
- SPACE moves between main menus
- Use ESC to hide this wand
- Use ? to get help information

```

Fig. 40. POJECTS page of STAFF.

Equipment **improvements and upgrades** were part of the assignments of the equipment maintenance staff. Jobs other than routine equipment repair, were listed in the TECHJOB tasks,

part of STAFF, online. TECHJOB was written in 1987 and renamed PROJECTS in 2008. See Fig. 40. Fig. 41 shows a detail of PROJECTS listings, with posting date added automatically. Upon completion supervisor moved the project into the archived job list.

```

Jobs for donnelly

Index  Pri      Need by Job
-----  ---  -----
1      1      fix cpa base pressure [7/14/2010]
2      1      replace ultek gate valve [11/1/2010]
3      3      rebuild cmp gearbox [7/14/2010]
4      4      dress wiring on ultek [6/18/2010]
5      5      cleanup randex looks [5/21/2010]
6      6      review ultek base pressure [6/18/2010]

[s]ummary, [a]dd, [d]elete, [r]enumber, [q]uit :

```

Fig. 41. Detail of projects listings

Improvement projects were continuous in the Microlab. There was never a period when there were not 5-10 projects listed for each technician/engineer. Records show that, on the average, at least one job/week was completed by each. The completed projects archive listing, besides record keeping, was also useful for the supervisor for performance evaluations.

A major factor in the Microlab’s ability to maintain its own equipment and to carry out development projects, was the existence of the Cory Hall Machine Shop. During major projects, such as the 6” upgrade [43], or the Microlab’s move into the NanoLab, the Machine Shop became practically the extension of the Microlab. (Fig. 42.)



Fig. 42. Microlab and Machine Shop staff moving equipment during the 6” upgrade (2000).

Record keeping was an important part of the activities of technical staff. When the Microlab opened in 1983, the first version of the lab management software was in place. Graduate researchers, PIs and staff, called lab members collectively, were required to login on the WAND, upon entry into the lab. Equipment enable/disable was among the first modules online, even if all tools were not yet connected. Virtual enable/disable was important for recharge accounting and for keeping track of processes and equipment use.

When a tool was disabled, the lab member was prompted to report problems if any, and/or make a comment regarding the process. At first, data was stored in flat files, which could be searched for information. This turned out to be insufficient for equipment management; thus, in 1990 a new research project was started, FAULTS: An Equipment Maintenance and Repair Tracking System Using a Relational Database [25]. This was David Mudie's Master's project, which required extensive input from the Microlab's equipment engineering staff.

Technicians had to compile a list of possible failure symptoms for each of their tools, short name and description, for example: wafer handling (cassette, indexer, orienter, transfer) or vacuum problem (no pumping, or does not reach required level). They also had to come up with a set of possible reasons (faults) for each symptom, such as indexer offset, or stuck gate valve. This information was entered in the database and could be edited as needed. The rigorous terminology was required to enable statistical failure analysis, which the program also provided.

When prompted for a problem report, the user was presented with a menu of symptoms, from which she/he had to select the appropriate description. The problem report was emailed immediately to the owner technician who would attend to the repair. It was also added to the Problems Status Board. Upon completing the repair the technician cleared the problem in FAULTS, by selecting the appropriate fault from the menu shown, and enter, in the comments section, details of the repair. At that point the problem report was removed from the status board.

Equipment users and support staff were required to follow the FAULTS problem reporting procedure, which was an immense help in equipment management. It allowed intelligent prioritization to provide optimum service for the ever growing lab membership. Fig. 46 is an illustration of the FAULTS status board.

```

Equipment:                               Symptom:
User:                                     Fault:
+-----+-----+
|MICROLAB FAULT REPORTS                  |
|=====|
|facilities: doors problem from marilyn (22-dec-2010 11:06:42) |
|pumps: roots pump problem from bob (29-dec-2010 11:35:48)   |
|topgun: valve-mfc problem from linan (01-nov-2010 15:12:57)  |
|tystar12: gas problem from wcchang (20-jul-2012 20:39:16)   |
|misc: maintenance problem from micro (01-jan-2011 05:00:30) |
|safety: maintenance problem from micro (01-feb-2011 05:00:30)|
+-----+-----+
Use ^JKFG and TAB to move around. Use ESC to execute a command.
Help End StatusBoard Read Update Clear Delete New Maint >

```

Fig. 43. Example page from the equipment problem reporting module, FAULTS.

4. Machine Shop

The Cory Hall Machine Shop played an important part in research support since the early 1950's. Design and construction of research instrumentation were a major part of the shop's activities, with 8-10 staff employees in those days. As research trends changed, the size of the shop was gradually reduced and staff reassigned to other units within the department. At the beginning, the Microlab's pumps were serviced by the Machine Shop, until this operation of the shop was transferred, along with James Parrish, Principal Lab Mechanician, to the Microlab, in 1987.

By 1994 the Cory Hall Machine Shop had only 2 employees, Joe Gavazza, Principal Laboratory Mechanician and Benjamin Lake, Principal Laboratory Mechanician, Supervisor. The shop became too small to maintain as an independent recharge unit; thus, EECS was considering closing it. Microlab management, with the help of several PIs, went immediately into lobbying-mode, because the availability of a machine shop was essential to running the lab. After several discussions, Prof. Mike Lieberman, ERL Director, and Prof. Felix Wu, Acting Chair of EECS, issued the following memorandum:

Effective July 1, 1994, to strengthen the fiscal and accounting aspects of shop operations and to provide a strong sense of direction, administration of the Machine Shop will be transferred to the Microlab. The machine Shop will remain a separate cost center, serving users as before, regardless of their affiliation to the Microlab. However, accounting, purchasing and other clerical functions will be managed by Microlab personnel. Ben Lake will continue to supervise the Shop, and all work should be brought to Ben for estimates, scheduling, etc., as is now done. We believe that this change will put our Machine Shop on a sound fiscal basis and will provide us with improved services.

At that point the Machine Shop's recharge account had a deficit of approximately \$120K. EECS and ERL accepted a third each and the Shop was left with \$42K to work off in the next several years. A new recharge rate proposal was submitted immediately; as Shop operations strengthened, the deficit was paid off in three years. EECS continued its support by committing to buy and use 200 hours shop time each year, at the going recharge rate. This agreement was still in effect at the time the Microlab closed; management of the Machine Shop was transferred effective 1 June 2013 to the NanoLab.

Early 1994, even before the Cory Hall machine Shop came under Microlab management, discussions were started between the departments of Materials Science and Mineral Engineering (MSME) and EECS, to consolidate their machine shops. Shop personnel in both departments had been reduced to two people, due to budget cuts, and the chairmen were exploring options for maintaining an efficient joint shop. Also, MSME was preparing for a major renovation and seismic retrofit of their building, the Hearst Memorial Mining Building, for which they would have to evacuate in the near future. In the Memorandum of Understanding (MOU), signed by the two chairmen, Prof. R. Gronsky, MSME and Prof. D. Messerschmitt, EECS, in July 1994, EECS agreed to house the joint shop in 185 Cory Hall, the location of the ERL Machine Shop. MSME staff were provided with their own benches and selected machines were moved over. Each group continued to serve their own clientele and, as the MSME shop was not a recharge operation, finances remained independent. Administrative and shop maintenance costs were shared equally by the two units.

The joint machine shop worked well and was able to maintain itself within the terms of the MOU; it provided both departments with high-quality, fine-scale machine shop services, in a timely manner. Sharing administrative services, tight cost control, and oversight helped the ERL half of the shop regain its financial health and to hire additional staff, in preparation for the Microlab's upcoming major project, upgrade of equipment to 6" wafer handling, 1998-2004. The MOU for the joint shop remained in effect after the completion of the renovation of the HMMB in 2002, and MSME, renamed Materials Science and Engineering (MSE) in 2000, shop personnel were able to move back. It is still in effect in 2013, with some modifications in practice. (No changes were made to the original document.) This means that MSE staff has full access to tools and can work in the joint shop as they need to. MSE withdrew from partial funding of the 0.5 FTE administrative staff, but pays for all materials used. MSE staff attends the monthly staff meetings and participate in maintenance.

The ERL half of the shop had four technicians fully occupied by the time MSE staff moved out, and was able, albeit precariously, to maintain its financial stability. The shop continued to remain an essential supporter of Microlab equipment and utilities maintenance. Shop staff also designed and built several major pieces of research apparatus, for example a plasma immersion ion implantation system (piii) in 1989, for Prof. Cheung's research and a rapid thermal chemical vapor deposition (rtcvd) tool for Prof. Hu's group, in 2001; these were unique pieces of equipment, not available in industry.

The Cory Hall Machine Shop played a critical role in the move of the Microlab into the Marvell NanoLab during 2010-2011. Without the Shop, the smooth transfer, avoiding shutting down the whole facility, could not have been accomplished. Shop staff has excellent skills and equipment for rigging, site preparation, plumbing and welding – besides their usual tool design and fine machining talents. (Fig. 44.) Since 2006, Nancy Peshette, Administrative Assistant, with special knowledge of machine shop tools and procedures, helped make the Shop into a successful operation.



Fig. 44.
Cory Hall Machine Shop Staff (2013).
L-R: Bill King, Development Tech. V,
Bob Amaral, Dev. Tech V,
Joe Gavazza, Principal Lab Mechanician,
Lou Ahtty, Dev. Tech V,
Ben Lake, Engineering Technical Sup.,
Machine Shop Manager.
<http://mshop-erso.berkeley.edu>

Of the total rechargeable hours of the Shop, Microlab jobs averaged about 38% in Fiscal Years (FY) 2005-2009. Microlab/NanoLab jobs were 46% of the total available recharge hours in 2009/10, 57% in 2010/11, and 49% in 2011/12. The rest of the time was recharged to jobs from other PIs from EECS, COE, CITRIS, ME, MSE, NE, L&S, practically the whole Campus. FY End Reports, documenting these numbers, were submitted to EECS/ERL/ERSO administration and to Microlab/NanoLab management each year, starting in 1994. The Cory Hall Machine Shop is well positioned for the research challenges of the coming decades.

5. Microlab Staff

When the Microlab opened in 1983 several staff were already on board. Don Rogers, who was the head of the departmental Glass Shop, was reassigned to oversee the construction of the new lab, and became its first manager. Bob Hamilton was transferred from the Glass Shop in 1983 to the Microlab and participated in all phases of equipment installations. (The Glass Shop on the roof was decommissioned in 1983 when the 5th floor of Cory Hall was added.) Dick Chen was hired for equipment and utilities installations in 1983, and worked for the Microlab until 1988. (He left for the job of facilities manager at UCSF.)

Process staff at the start were Dorothy McDaniel, who was a laboratory technician in the Integrated Circuits lab (now combined with the Microlab) and Kim Chan, photolithography specialist, already working with Professors Oldham and Neureuther's research group. Kim Chan is still with the lab, an R&D Engineer 2; Dorothy McDaniel retired in 1984.

Staff added for the start-up of the new lab were, in 1984: Rick Harper, Electronics Technician (resigned in 1986), Steve Hoagland, Electronics Technician, (transferred to another department on Campus in 1989), Marilyn Kushner, Laboratory Assistant (still with the lab as an R&D Engineer 2), Robin Wallach, administration (later Process Supervisor, left in 1989).

In 1985 most major tools for 4" silicon processing were in place and Microlab activities began to expand. Additional staff came on board and a process development engineer was hired. Fig. 45 shows the list of Microlab staff in 1985. [4]

Microfabrication Facility Staff	
Professor Ping Ko	<i>Faculty in Charge</i>
Don Rogers	<i>Senior Development Engineer, Manager</i>
Robert Hamilton	<i>Associate Development Engineer, Supervisor</i>
Katalin Voros	<i>Associate Development Engineer, Supervisor</i>
Christy Atases	<i>Principal Clerk</i>
James Batie	<i>Principal Electronics Technician</i>
Dick Chan	<i>Development Technician III</i>
Kim Chan	<i>Staff Research Associate II</i>
Phillip Guillory	<i>Senior Electronics Technician</i>
Rick Harper	<i>Electronics Technician</i>
Steve Hoagland	<i>Electronics Technician</i>
Marilyn Kushner	<i>Laboratory Assistant III</i>
Robin Wallach	<i>Senior Typist Clerk</i>

Fig. 45. Microlab staff list in 1985.

Don Rogers retired at the end of 1986 and Katalin Voros took over management in January 1987. That year the staff structure, shown in Fig. 46 [14], began to form.

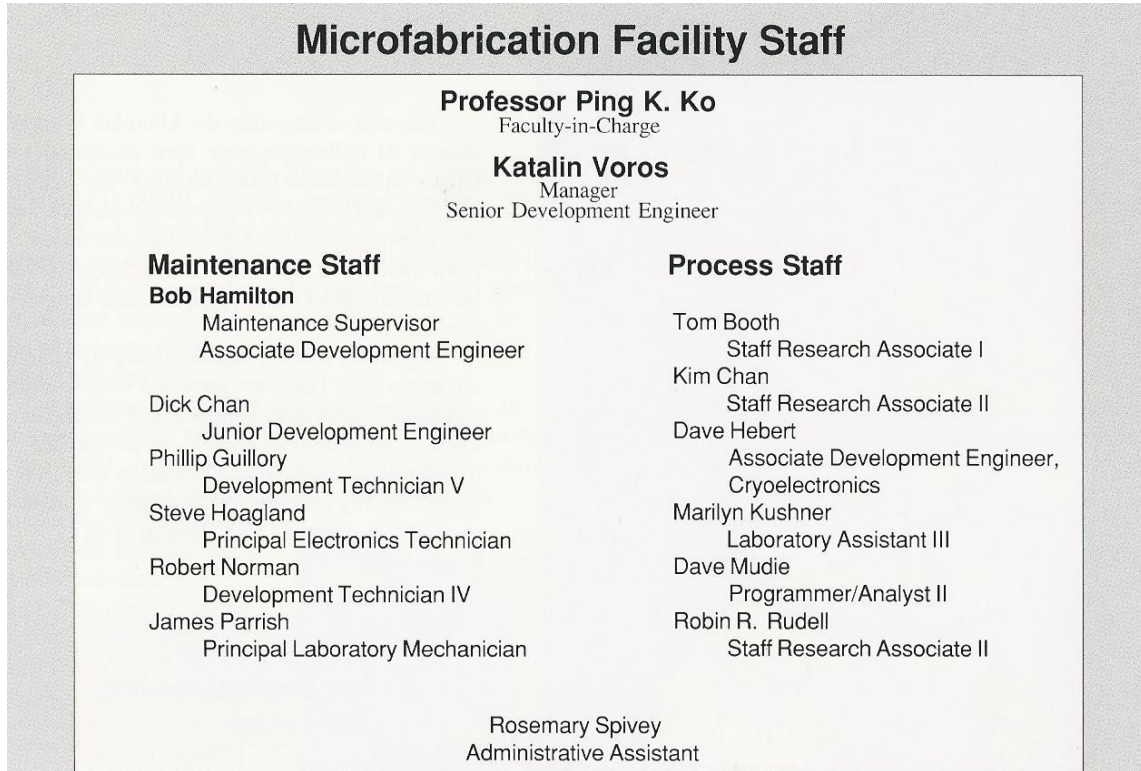

Fig. 46. Microlab staff list in 1987.

A clear definition of responsibilities required grouping staff under supervisors; thus, development in this direction began when Bob Hamilton and Rosemary Spivey attended the Effective Supervision short course offered by Campus Personnel. (No HR yet at that time.)

By 1989 the basic organizational structure was formed and remained in effect through the life of the Microlab. Support staff were assigned into three groups, **Maintenance**, **Process**, and **Administration**. A fourth one, **Computers**, was added in 1991, when BCIMS research and lab support were separated and “production” staff was hired to support the Microlab’s growing computer system, both hardware and software. (See Fig. 47.)

One more group developed organically from the start, **Associated Researchers**. They were employed directly by research groups; post-doctoral fellows or other professionals, who worked with the graduate students of the group, and/or had their own research projects. Administratively they were listed under the Microlab, but they were funded and supervised by the PIs. Associated researchers were charged lab fees and had no maintenance responsibilities; however, they were great contributors to the general knowledge within the lab and were often helpful, not only to students within their group but also others. As lab membership grew and large research groups developed, Microlab management actually encouraged PIs to hire their own staff, to provide continuity and to leverage staff skills toward a more timely progress of projects. BSAC, the largest research group since the first years of the Microlab, was very successful with this model, starting in 1991, when they hired a Senior Development Engineer, James Bustillo. Later two other BSAC engineers were added.

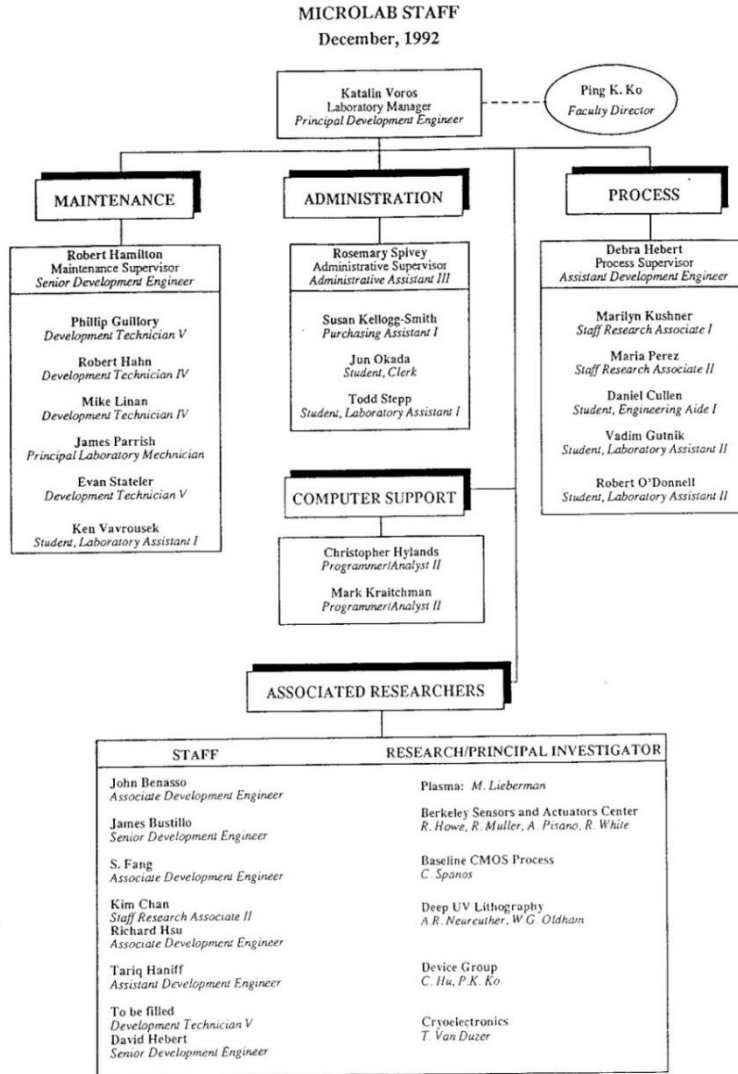

Fig. 47. Microlab organizational chart in 1992.

Maintenance Staff

Responsibilities of the maintenance staff were detailed in the earlier, 3. *Equipment*, section. The number of technicians, including the supervisor remained at 6 for 10 years. Part time student assistants were employed to help out as needed. As lab membership grew, the group increased to 10 in 1999, and reached 13 in 2001, at the height of the 6" tool upgrade (1998-2004). During this same period the Microlab expanded into satellite labs on the first floor of Cory Hall, where the Planarization and Thin Film labs were created – mainly because three 6" tools were too large to place in the Microlab. Also at this time, renovation of the Hearst Memorial Mining Building started, which required major preventive activities on the utilities front. To manage the increased work load, two supervisory positions were created: Phill Guillory, a CA licensed electrician who started at the Microlab in 1985, became Facilities Manager in 1999, and Mike Linan, who started, transferring from another department on campus, in 1990, became Projects Manager in 2001. Both were reclassified into Development Engineering titles. Phill and Mike were the first two engineers to be transferred to the Marvell NanoLab, when it was ready for equipment site-preparation (2009).

Summary of Equipment Engineering responsibilities:

- Equipment installation
- Routine and scheduled maintenance
- Access control installation – enable/disable
- Equipment “ownership”
- Equipment repair – FAULTS reports
- Equipment development – upgrades
- Utilities installation – to machines
- Utilities monitoring, service – BLIMP/WIS
- Infrastructure upgrades – power, water, air
- Specialty gas management
- Effluent management

Equipment engineering was under Bob Hamilton’s supervision/management through the life of the Microlab, 1983-2010. Staff transferred with him to the NanoLab in 2009-10:



Phill Guillory
R&D Engr. 3
Facilities Mgr.
26 years

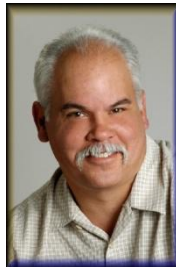

Mike Linan
R&D Engr. 3
Projects Mgr.
22 years



Evan Stateler
R&D Engr. 4
13 years



Joe Donnelly
R&D Engr. 3
11 years



David Lo
R&D Engr. 3
11 years



Bryan McNeil
Dev. Tech. V
10 years



Danny Pestal
R&D Engr. 4
8 years



Jay Morford
R&D Engr. 3
4 years



Al Briggs
Dev. Tech. III, 3 yrs.

Also worked for the Microlab:

Dick Chan, Jr. Dev. Engr. 1983-88
S. Hoagland, Assoc. Dev. Engr. 1984-89
Brad Bigham, Prin. Elect. Tech. 1985-89
Robert Norman, Dev. Tech. V 1986-92
James Parrish, Prin. Lab. Mech. 1987-2004
Robert Hahn, Dev. Tech IV 1992-93
C. Williams, Assoc. Dev. Engr. 1994-02

Patrick Wehrly, Asst. Dev. Eng. 1994-04
John Simon, Dev. Tech. V 1997-98
Scott Larieau, Dev. Tech. V 1998-99
Steve Gidden, Dev. Tech. V 1998-2000
Bob Connelly, Dev. Tech. V 1999-07
Perty Kaksonen, Dev. Tech. V 1999-06
Mario Lizardo, Dev. Tech. III 2001-04
Antal Kovats, Assist.Dev. Eng. 2006-07

Process Staff

Microlab management believed that a process engineering group was **essential** to ensure continuous process capability, integrity of process cleanliness, and that an effective process staff is the key to future developments. Thus, as a first step, K. Voros was hired as a process engineer in January 1985, in charge of establishing a CMOS process with standard modules. This was accomplished and documented in an ERL Memorandum, *MOS Processes in the Microfabrication Laboratory* (March 1987) [10].

K. Voros trained Robin (Wallach) Rudell, who had a strong chemistry background, in processing. When Katalin became lab manager in 1987, Robin assumed the role of Process Supervisor, in 1988. She also participated in redesigning the EE 143 test chip and process. The lab manual, *EECS 143 Processing and Design of Integrated Circuits Laboratory Project*, came out in August 1988, and it is still being used, with minor modifications, today [15]. Another project Robin worked on was the lab's first informational video, *Microfabrication at Berkeley*, 1989, with the cooperation of the Campus TV Office. (Robin resigned at the end of 1989.)

Thus, the Process group became one of the main components of operating the Microlab successfully. The Staff Research Associate job classification (mapped into the R&D Engineering series in Career Compass in 2008) requires graduation from college (B.S.) with a major in an applicable science plus some years of experience. The level within the series depends on the kind of work to be performed and/or an equivalent combination of education and experience.

Process staff carried out so-called staff projects, such as complete or partial integrated circuit **processing**. On occasion these would involve collaboration with students on joint projects. Also, process staff provided continuity of information for the ever-changing user base.

In 1986 process engineering introduced the Engineering Test Request (**ETR**) form, still used today, to handle special processing requests from lab members and outside institutions. As lab operations stabilized, staff was able to fulfill these requests, at hourly staff charges. Requests for **Mask-making** soon became the most common job. During the period of 2000-05 there were years when Marilyn Kushner made over 1400 photo-masks for lab members and university-affiliated clients. This number leveled off at around 1000, as other labs began to make their own masks. Details can be seen at <http://microlab.berkeley.edu/text/maskmaking.pdf>.

Processing requests (and income) reached their peak during the Microlab's participation in the **MEMS Exchange**, from 1998 – 2008. Jim Bustillo, the Microlab's Technology Manager since 1996, shared half time with BSAC, was instrumental in implementing this program. The MEMS Exchange (MEMSX,) later renamed the MEMS and Nanotechnology Exchange (MNX), <https://www.mems-exchange.org>, is a DARPA-funded project to provide MEMS-base fabrication to researchers nationwide via a web-based network. The program is administered by the Corporation for National Research Initiatives (CNRI). The Microlab was the first laboratory to offer MEMS processing services, at jointly agreed upon module fees. CNRI funded two process engineers from 1998-2003, to kick-start the program. They continued with a reduced level of support through 2008. (2004: 1.5 FTE, 2005-06: 1 FTE, and 2007-08: 0.5 FTE) Additional process engineers were hired to do this work: Eunice Koo, Roger Su, and Daniel Bucher.

Process staff also carried out **operational maintenance**. This included: new process development and characterization; process testing after tool repairs; calibration of analytical instruments; scheduling lamp changes in exposure tools; operating restricted equipment, such as scanning electron microscopes (SEM). At first, **process monitoring**, such as checking standard film thicknesses produced by a tool, or gate oxide thickness and mobile ion measurements, were done by process staff on an as needed basis. In 1992 a regular process monitoring program was initiated, along with the Baseline project (discussed below,) with statistical process control limits and alarms. Standard process monitoring was carried out and recorded online, by student assistants, under the supervision of Marilyn Kushner. Details can be seen here: <http://microlab2.eecs.berkeley.edu/ProcessMonitor/index.html>

Process staff was responsible for **maintaining equipment manuals**. Serving a diverse user community required that manuals contain up-to-date information on operating the tools and on standard processes. With 130 pieces of equipment this was a major time investment, resulting in 1381 manual pages, grouped in 157 chapters (2008 data) – all online since 1984.

Manual writing became much more formal when Sia Parsa, who came as an experienced process engineer from industry in 1998, introduced a standard format. In 2000 process staff started to migrate the chapters from ASCII formatting to web-based display. The 6” upgrade project, during which half of the tools were modified and required updating the manuals, provided impetus for the conversion. Madeleine Leullier, Computer Resource Specialist, with the Microlab since 1996, was assigned document control; she reformatted the manual chapters for web display. Madeleine was also responsible for maintaining web content, as requested by management.

Management of **equipment qualifications** was the responsibility of the process staff. A tradition which started in the “old lab” continued to flourish in the Microlab: students trained one another in the use of equipment. After a new user demonstrated to the “Superuser” to have sufficient skills to operate the tool, her/his login name was added to the qualified users list for that tool. This meant that the student could enable the equipment and could work independently. Qualifications were required for each tool separately, also for those similar in operation. Because Microlab membership was working in many different research areas, with the possibility of processes cross-contamination, each tool had different restrictions, like what materials were allowed in it, or what baths were available for which processes. Even in the case of sinks, separate tests were required. As Microlab membership increased precipitously during the mid-1990’s (and passed 200 in 1996,) written equipment tests were introduced for the more complex tools, to insure proper training. These tests were created and administered by the process staff. By 2010, 35 such tests were part of the qualification requirements.

Process staff participated in lab orientation seminars, gave lab tours to new students, prospective lab members, and visitors. They were active in preparing **public relations** materials and gave informational presentations.

Another important activity involved lab cleanliness. Managing students’ work storage and space reorganization were unending jobs and required a positive attitude. Marilyn Kushner was a major force in this endeavor. She managed to turn the yearly **Clean Fests**, in which all members were requested to participate and the lab was literally scrubbed down, into a rewarding event, with prizes and snacks.

Summary of Process Engineering Responsibilities:

- Standard process – for each equipment
- Process modules – set of steps to create a complete process
- Process testing after equipment repair
- Process monitoring, statistical process control – limits, charts
- Standard CMOS process – "baseline"
- Compatibility policy – contamination control
- Process and equipment operation manuals maintenance – on-line
- Managing qualifications for equipment operation
- Managing students' work storage and space reorganization
- Organizing yearly clean-fests
- Lab orientation, lab members' meetings, visitors, public relations

Process Engineering supervisors, 1987-1998:



Robin Wallach Rudell
Staff Res. Assoc. III
1987-1989



Debra Hebert
Assist. Dev. Engr.
1989-1994



Maria Perez
Assist. Dev. Engr.
1994-1995



John Knudsen
Assoc. Dev. Engr.
1995-1998

Process Engineering staff transferred to the NanoLab in 2010:



Siavash Parsa
R&D Engineer 5
Process Eng. Manager from 1998
12 years



Kim Chan
R&D Engr. 2
28 years



Marilyn Kushner
R&D Engr. 2
26 years



Jimmy G.-M. Chang
R&D Engr. 4
14 years



Madeleine Leullier
Comp. Res. Spec. II
14 years

Other process engineering staff who worked in the Microlab:

Dorothy McDaniel, Senior Electronics Technician, 1962-1984
Tom Booth, Staff Research Associate II, 1984-1990
Richard Hsu, Associate Development Engineer, 1988-1993
Tariq Haniff, Staff Research Associate II, 1990-1993
Marcelle Stagno, Jr. Development Engineer, 1993-1995
Waylen Wang, Staff research Associate II, 1996-1997
Eunice Koo, Associate Development Engineer (MEMSX), 1998-2005
Roger Su, Associate Development Engineer (MEMSX), 1999-2004
Daniel Bucher, Assistant Development Engineer (MEMSX), 2005-2007
Attila Szabo, Assistant Development Engineer (MEMSX), 2006-2007

Baseline Engineering

In 1985, when the majority of equipment for MOS processing was in place, K. Voros was hired to establish a standard (baseline) process. Plans were to run CMOS lots continuously, as a foundry service for systems researchers. Soon it became clear, that this program was too ambitious for the facility, and the Microlab could not meet the time and complexity demands of the circuit designers. MOSIS, the DARPA/NSF initiated fabrication service, became available just about at that time and the need for in-house service diminished. However, several graduate student IC researchers were successful in processing their designs in the Microlab and also worked with staff on composite chips. Examples follow. (See Fig. 48-52.)

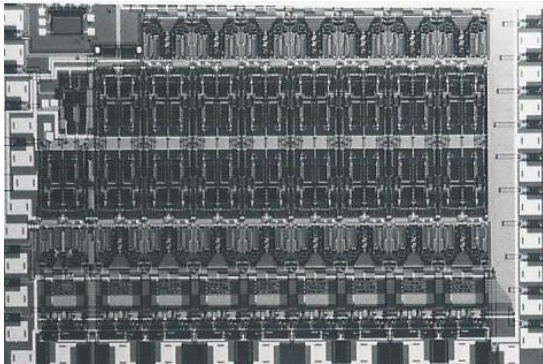

Fig. 48. Pipelined A/D converter.
L.C. Yiu, Prof. Gray, 1987.

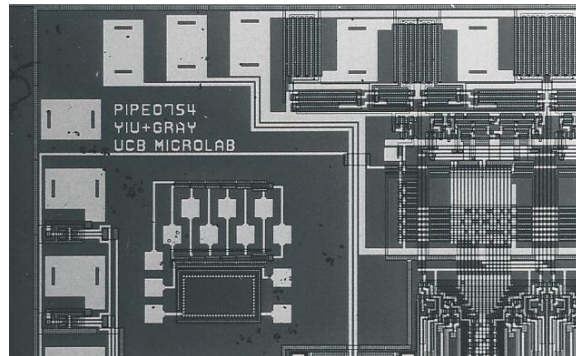

Fig. 49. Detail of Fig. 48,
with UCB Microlab.

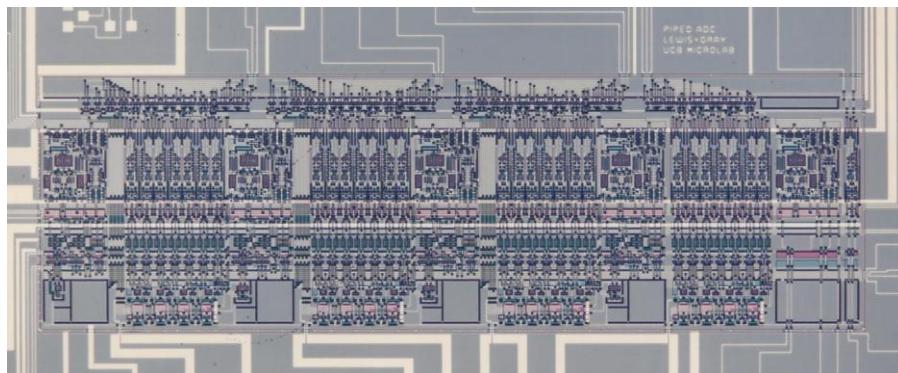

Fig. 50. Pipelined 9-bit A/D converter.
S. H. Lewis, Prof. Gray (1986).

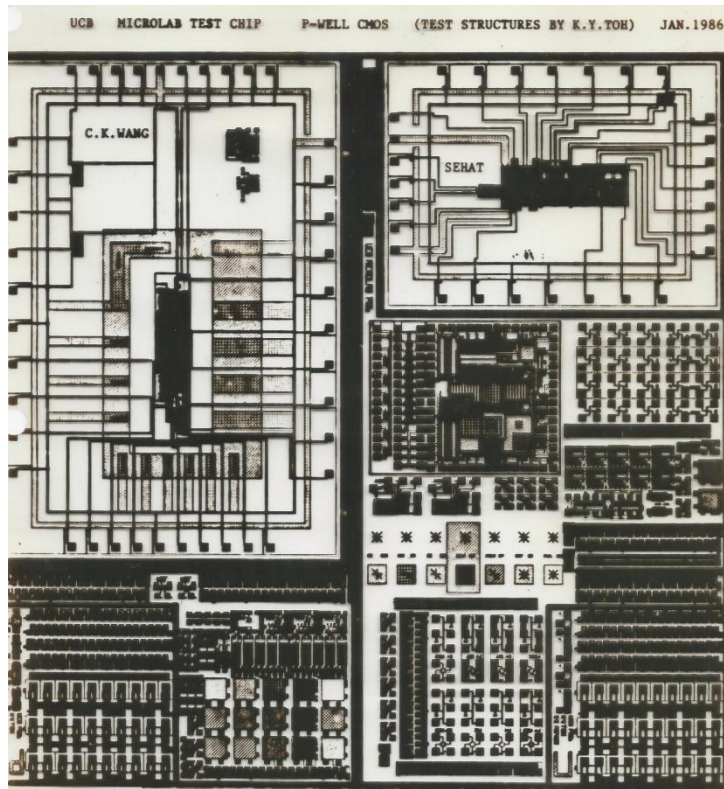

Fig. 51. Layout of composite chip fabricated in the Microlab.
C.K. Wang, S. Sutardja, K.Y. Toh (1986).

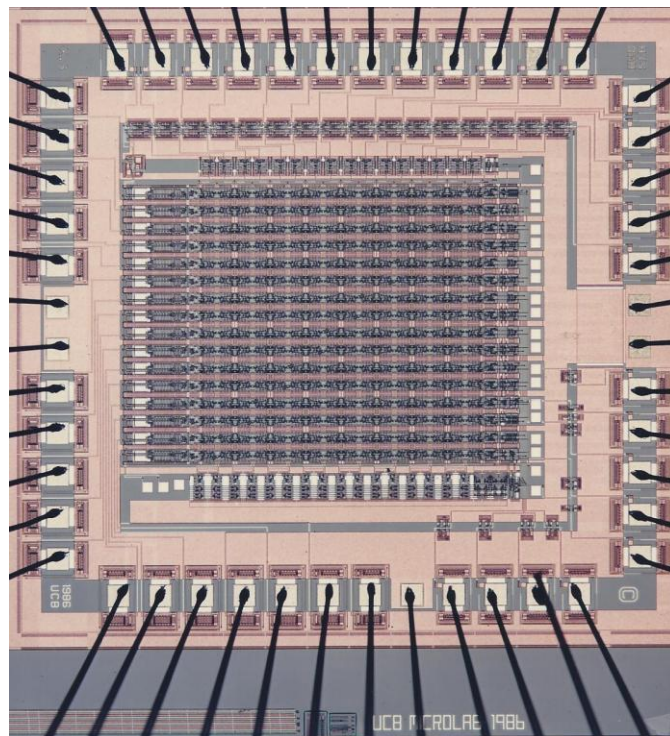

Fig. 52. CMOS 250 Mb/s cross-point switch.
H. J. Shin, Prof. Hodges (1986).

The Microlab's MOS processes were documented in an ERL memorandum, *MOS Processes in the Microfabrication Laboratory* (March 1987) [10], and were available to all members to apply to their own projects and/or to modify as needed. The Sensors and Actuators group was interested in combining sensing elements and signal processing circuitry on the same chip. One such example is shown in Fig. 53.

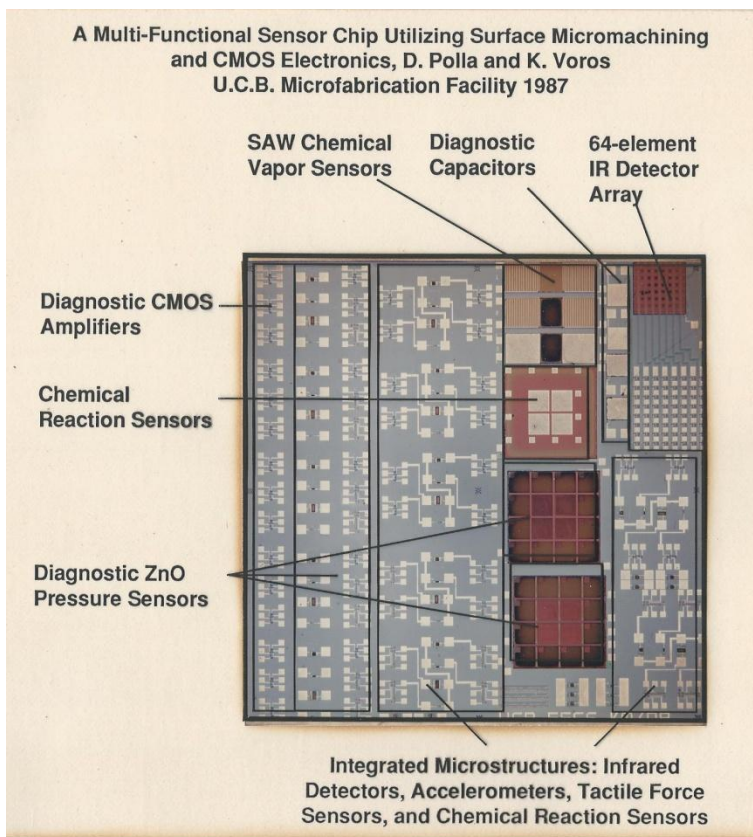

Fig. 53. Multifunctional sensor chip with CMOS ICs.
D. Polla, K. Voros (1987).

After K. Voros became manager of the Microlab in December 1986 the process engineering position was not filled, for financial reasons. Without additional funding the operational budget was not sufficiently robust to carry silicon process development work. This situation changed for the better in 1992, when Prof. Spanos initiated a joint baseline-fund and received contributions of about \$60K, from the CIM (Spanos, Hodges), Device (Hu, Ko, Cheung), BSAC (Howe, Muller, White), IC (Gray) and Cryo (Van Duzer) groups. Microlab operational funds were applied to complete the support of a dedicated baseline engineer. Baseline-fund contributions continued, albeit slowly diminishing, for 8 years, when the project could be supported completely by funds generated from the Berkeley Microlab Affiliates (BMLA), industrial membership program.

The stated purpose of the baseline project was to maintain standard process modules used by all groups and to produce CMOS circuits for the supporting groups. The operation of the baseline was to provide feedback on equipment performance and to maintain process calibration. These goals were met, as documented by EECS/ERL Memoranda submitted by each successive baseline engineer at the end of her/his tenure.



Shenqing Fang (MS degree, U. of Hawaii, 1991) joined the Microlab as an associate development engineer for the CMOS baseline project, in April 1992. (He resigned in 1995, to continue his studies as a PhD student.) He recalibrated the CMOS process established earlier (1987), by using a new test chip, designed by Paul Krueger [16]. The new pad layout allowed for automatic testing, to provide data for statistical process simulation. Prof. Spanos' research funded the acquisition of an Electroglas automatic probe station (autoprobe), capable of testing 4"-8" wafers, with computerized data collection. Vadim Gutnik, undergraduate laboratory assistant wrote the test programs, with assistance from the CIM group. The baseline supported a 2 μ P- and N-well, double poly-Si technology. S. Fang's report, *CMOS Baseline Process in the UC Berkeley Microfabrication Laboratory*, was submitted in December 1995 [31].



S. Fang trained his successor, **Goubin Wang** (MS degree, Xinjiang University, PRC, 1988, visiting scholar at Yale, 1994-95). Goubin continued with process development by shrinking critical dimensions (CD) and starting at 1.3 μ m, twin-well, double poly-Si, double metal process run. 2 μ m fabrication requests were completed for the BSAC and BCAM groups; sample wafers for testing were donated to researchers at Caltech, Hong Kong U., and HKUST. Goubin resigned in 1999 and accepted a position at LBNL.



There was a four-month hiatus before the next baseline engineer, **Laszlo Voros**, arrived in November 1999. (No relation to K. Voros.) A recent, June 1999, graduate of the Technical University of Budapest (MS in Engineering Physics), Laszlo was trained on the autoprobe first. Sia Parsa, Process Engineering Manager, guided him through the intricacies of processing. Laszlo reported the test results and the process flow of the 1.3 μ m, twin-well, double poly-Si, double metal process in an EECS/ERL memorandum, *CMOS Baseline Process in the UC Berkeley Microfabrication Laboratory, Report II*, December 2000 [35].

The 6" upgrade project was the next challenge for the baseline. The new photolithography tool (ASML 5500/90 4X wafer stepper), ready for characterization in early 2000, enabled 6" wafer processing, but required a new type of reticle (mask) set and DUV wavelength photoresist process – all new to the Microlab. Laszlo modified the test chip layout and worked with Sia Parsa on the lithography process. The baseline CMOS lot became the test vehicle and priority driver of the of the 6" upgrade. The ERL memorandum by L. Voros and S. Parsa, *Six-Inch CMOS Baseline Process in the UC Berkeley Microfabrication Laboratory*, [Report III] came out in December 2002 [39].

The upgraded lithography module, with the ASML 4X stepper, was capable of defining sub-half-micrometer features; thus, the baseline process was redesigned to produce transistors with 0.35 μ m gate lengths. Hin Yung Wong, Prof. King Liu's graduate student assisted with extensive process simulations. The project continued with Attila Horvath (MS, Technical University of Budapest, 2002), the new baseline engineer, who arrived in November 2002. This time there was an overlap to allow for training and to complete additional, smaller projects. Laszlo Voros left in June 2003, to become a licensed radiation physicist, now working at the Memorial Sloan-Kettering Cancer Center in New York.



Attila Horvath continued the 0.35 μm process development and also assisted with the FlexFET joint project with Prof. Parke's research group at Boise State University, Idaho. Processing was done in the Microlab and required an all-out effort by the process staff, including the baseline engineer. The FlexFet project was instrumental in pushing the upgraded 6" tool set to their possible maximum performance. The effort paid off handsomely on the subsequent 0.35 μm lot. The high yielding lot utilized gate work-function engineering, lightly doped drain, with 80 Å of gate oxide. The results were discussed in the ERL memorandum, *0.35 μm Process on Six-Inch Wafers, Baseline Report IV*, April 2005 [44].

Attila compiled a new, composite baseline chip from three different research groups; processing this chip provided a vehicle to train the new baseline engineer, Georg Vida, who arrived in September 2005. Attila Horvath went back to Europe to work for electronics firms, first in Hungary, then in Norway. Later he returned to the San Francisco Bay Area, where he now works for a start-up.



George Vida (MS, Technical University of Budapest, 2002) was the Microlab's baseline engineer from September 2005 to October 2006. He continued processing and testing the composite chip, which had an IC/MEMS design, a hyperacuity circuit and several different memory circuits. Groups who submitted the designs received wafers for testing in their own systems. George trained the baseline engineer next in line, Anita Pongracz, who arrived with one month overlap, in September 2006. Their joint ERL memorandum, *0.35 μm Process on Six-Inch Wafers, Baseline Report V*, was submitted in February 2007 [45]. George returned to Budapest and works for a patent law firm.

Anita Pongracz (MS, Technical University of Budapest, 2004) took time off from her PhD studies to spend a year in the Microlab as a baseline engineer. She completed the lot, started by George Vida, with the composite chip design, and started a new one with modifications to improve device performance. Also, a new, mix-and-match lithography process module was developed, which applied DUV lithography using the ASML stepper for half of the 22 photo steps, and for the other half, less critical steps, the GCA I-line wafer stepper. The mix-and-match process relieved demand on the sensitive ASML stepper. Anita returned to Budapest in December 2007. She completed her PhD and is now working as a research fellow at the Institute of Technical Physics & Material Sciences, Hungarian Academy of Sciences, MEMS Lab. <http://www.mems.hu/>



Laszlo Petho (MS, Technical University of Budapest, 2006) arrived in November 2007 and was trained by Anita Pongracz. After Laszlo completed the lot started by Anita, their joint *Baseline Report VI* came out in December 2008 [48]. Laszlo designed and processed a new composite chip, with MEMS structures and features for carbon nanotube integration and nano-wire based molecular sensors. The lot yielded well, which he documented in *Baseline Report VII*, December 2009 [49]. This process was repeated to serve as basis for comparison, in preparation for the move of the Microlab into the new Marvell Nanolab. Also, Laszlo designed the mask set for the new ASML DUV Stepper, Model 5500/300, installed in the new lab, and trained the new baseline engineer. Laszlo left in September 2010

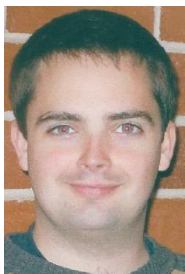

and now holds the position of Scientific Assistant at the Center of MicroNanoTechnology of the Ecole Polytechnique Federale de Lausanne.



Anna Szucs, the last baseline engineer also studied in Budapest, but completed her MS degree at Arts et Métiers Paris Tech (ENSAM), in 2010. She started at the Microlab in August 2010, right in the middle of the lab move. Her assignment was to validate process functionality in the new lab. The original plan of repeating the last run completed in the Microlab needed to be modified because the tool set was partially different. The lithography module had to be re-characterized with the new exposure tool, and the plasma etchers were replaced with newer models. In spite of the changes and moving delays, Anna completed two wafers with the first functional transistors in the Marvell NanoLab. She submitted her report *The First Baseline Run in the New Marvell NanoLab, Baseline Report VIII* [50], after she left, in February 2012. Anna continues her PhD studies at the Doctoral School EEATS, Grenoble.

Below are shown two examples of baseline chip layouts. Both were processed in 0.35 μm , double poly-Si, double metal with silicide technology. (Fig. 54 and 55.)

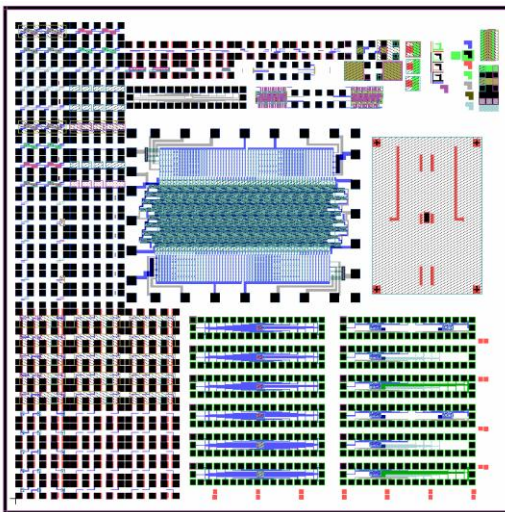

Fig. 54. Layout of composite chip from Baseline Report V [45].

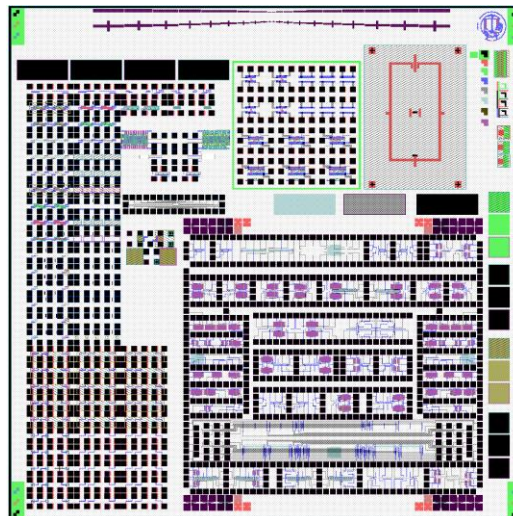

Fig. 55. Layout of composite chip from Baseline Report VII [49].

Candidates for the position of baseline engineer were selected from email applicants and referrals. S. Fang applied from the U. of Hawaii, and G. Wang was referred by Prof. T. P. Ma at Yale. Professor Janos Mizsei at the Technical University of Budapest, Faculty of Electrical Engineering and Informatics, Department of Electron Devices, assisted in selecting the successive candidates from his school.

The baseline project, which ran for 20 years, from 1992 to 2012, fulfilled its mission successfully. It provided process continuity, with gradual development as the equipment improved, provided data for statistical process control and chips for research groups. Baseline engineers also participated in other aspects of silicon processing, such as ETRs, special module development and joint projects, as the need arose. They worked directly under Sia Parsa, Process Eng. Manager's supervision and were a great addition to the process staff.

Two major challenges required the baseline to be the vanguard of process validation in the Microlab: the 6" upgrade (1998-2004), when the tools for Si processing were upgraded and/or changed, or effected in some way; and the move of the Microlab into the Marvell NanoLab. In both cases, baseline requirements, which were the needs of the two largest groups in the lab, MEMS and Device, determined priorities. In both cases, changes and moves were made while the lab was in full operation. This tactic could have happened only by the absence of time constraints, except for those of the research projects.

Upgrade/move plans were developed keeping process sequences in mind and only affected tools were down, for as short a period of time as possible. Once modifications were made or the tool sited in its new location, process staff switched into high gear to re-characterize the process. A new baseline lot was started as tools came up and it was ready for the next step as soon as the tool was there. It turned out that the 6" upgrade, in hindsight, became the rehearsal for the big move in 2009-10.

Eight years after the initial joint funding, baseline expenses: salary and benefits for one FTE and occasional student help, lab fees, expenses of wafers, masks, ion implantations and analytical services, were fully funded by the BMLA program. The baseline project was well worth the effort on the part of the management and the investment paid off handsomely in Microlab capabilities and smooth operation.

Associated Researchers

Associated researchers provided great help to operations. At the start of the Microlab in 1983-85, post-doctoral fellows of Professors Oldham and Neureuther, J. Shacham and F. Dupois shepherded through the first graduate class in CMOS processing [7] [8]. Also, several graduate students helped, way beyond expectations. Most remembered from the early days were: Ping-Wai Li (1984, Prof. Gray), Hae-Seung Lee (1984, Prof. Hodges), Chuck Dennison (1985, Prof. Ko), Kai-Yap Toh (1986, Prof. Meyer), Albert T.-T. Wu (1987, Prof. Hu and Ko), Pei-Lin Pai (1987, Prof. Oldham). Also, several graduate students helped with implementing computer control in the lab. They will be listed under Computer Support.

All major research groups in the Microlab employed, from early on, dedicated staff to work with graduate students on group projects. In some cases they maintained equipment used by their own group. They developed processes which then became available to all lab members, and were knowledgeable advisors on a broad range of processing issues. Associated researchers were great lab members and were respected for their insights and valuable contributions to Microlab operations. The following staff worked directly with research groups:

Cryo-electronics, Prof. Vanduzer: David Hebert, Senior Development Eng., 1986-1995

Xiaofan Meng, R&D Engineer IV, 1995-2013

Device: Hideki Takeuchi, Research Engineer, 1997-2005

BSAC: James Bustillo, Principal Development Engineer, 1991-2000

Angad Singh, Associate Development Engineer, 1996-2000

Matthew Wasilik, Senior Development Engineer, 2000-2010

Michael Young, Senior Development Engineer, 2000-2002

IML: Prashant Phatak, Senior Development Engineer, 1996-1998

Robert Prohaska, Senior Development Engineer, 1998-2005

Plasma Lab, Professors Lieberman and Cheung: John Benasso, Assoc. Dev. Engineer and

David Baca, Assistant Development Engineer, 1994-1998

Administration

As an independent recharge unit within ERL/ERSO, the Microlab handled its own administration, which involved all aspects of the operation: finances, accounts management, procurement and inventory, staffing, and business administration. This group was established, partially carried over from the “old Lab”, in 1983, by the lab’s first manager, Don Rogers. He hired Rosemary Spivey in 1985, who remained in the position of Administrative Manager until the Microlab closed at the end of 2010. As lab membership grew and systems and controls were established by management, including Rosemary, she developed the administrative staff to handle the Microlab’s “business” comprehensively .

Because the Microlab received its own charge account (independent of ERL) only in 1985, Rosemary’s first job was to sort out where the Microlab stood financially. This was followed by extensive analysis and reporting requested by lab management and compiling of the yearly recharge rate proposal. Budget numbers for all categories were established and the lab’s financial performance was monitored closely. The yearly budget of the Microlab grew from \$600 thousand (FY 1986/87) to \$4 million (2010/11), which was managed by Rosemary.

Management believed in keeping finances transparent; thus, the first detailed Fiscal Year-End (FYE) Report was published in September 1990. (Previous numbers, for FY 88/89 and FY 89/90, were included in the [calendar] year-end summary reports K. Voros submitted to the Faculty-in-Charge, starting with 1987, the year she became lab manager.)

The administrative manager submitted a FYE report each year, which was sent to all participating PIs and EECS/ERL leadership. Monthly financial performance monitoring reports were provided to Microlab management for review and for corrective action if/when needed. After the Microlab “inherited” the Machine Shop (1994-2013) and the Integrated Materials Lab (1996-2004), each a separate recharge account, reports were compiled for these also.

Lab member accounts’-management was another major activity. Membership (i.e. number of accounts) increased from barely over 100 to 500 in 2009, just before the move. Posting charges to 300 different grants, on the average, was unique in ERL. It could only be done by the excellent Accounting module of BCIMS, which also provided reports and uploading capability to UCB’s financial ledger. Uploading was accomplished only later, from the early 2000’s, when the very unfriendly Campus accounting system was upgraded. A second upgrade occurred in the middle of the decade, creating additional work for the administrative staff.

Rosemary’s right hand was Susan Kellogg-Smith, who managed procurement and inventory since she started working for the Microlab in 1989. Paralleling the membership increase in the 1990’s, the number of purchase orders grew from 120/month in 1995 to 200/month in 2008 and inventory items from 1472 items to 1700 items (60 categories), in the same time period.

The reception/front desk duties included servicing lab member requests for inventory items, administering qualification tests, filing, making copies and a host of everyday duties. The position did not offer development opportunities; thus, it was difficult to fill it with career employees. Often reception duties were looked after by undergraduate student employees.

Summary of Administrative Staff Responsibilities:

- Fiscal management
 - Supplies and expenses
 - Salaries and benefits
 - Income
 - Recharge rates proposal
- Budget and accounts management
- Procurement and inventory
- Staffing and payroll changes
- General administration
- Reports

Microlab Administration was under Rosemary Spivey's supervision/management through the life of the Microlab, 1984-2010. Staff transferred with her to the NanoLab in 2009-10:



Susan Kellogg-Smith
Buyer II
Purchasing Manager
21 years



Adrienne Ruff
Admin. Assistant III
10years



Nancy Peshette
Admin. Assistant III
4 years



Eric Chu
Adm. Assistant III
1 year

Also worked in Microlab Administration:

Eileen O'Neill, Administrative Assistant I, 1997-1998

Leon Tsao, Administrative Assistant III, 2000-2004

Many undergraduate work-study students worked at the reception desk.

Computer Support

The Berkeley Computer-Integrated Manufacturing System (BCIMS) was a research project started in 1982 by Professors D. Hodges and L. Rowe of EECS and R. Glassey of IEOR. Professor C. Spanos joined in 1988. The goal of the project was to render the Microlab paperless and to provide a management information system for efficient operation of the lab. BCIMS will be described in a later chapter, *VII. Computer Information and Management System*.

Because the Microlab provided a test bed, it enjoyed full computer support from the CIM research group (Professors Hodges, Rowe, and Spanos) the first seven years, through FY 1990; partial support was provided through 1995.

Summary of Computer Support Staff Responsibilities:

- Maintenance of Microlab servers and related hardware
- Maintenance of local area network and equipment communications
- Maintenance of equipment control and utilities monitoring computer
- Maintenance and upgrade of servers and PCs used by staff
- Software maintenance, upgrades, security
- Database management and upgrades
- Software development as requested by management

Graduate Students who worked on BCIMS as part of their research:

Michael F. Klein (PhD 1985, Prof. Hodges)
 Mauricio G.d.C. Resende (PhD 1987, Prof. Glassey)
 Christopher B. Williams (MS 1987, Prof. Rowe)
 Amit Sharma (MS 1988, Prof. Hodges)
 Norman Chang (PhD 1990, Prof. Spanos)
 Christopher J. Hegarty (PhD 1991, Prof. Rowe)
 Brian Christopher Smith (PhD 1994, Prof. Rowe)
 David Mudie (MS 1991, Prof. Hodges)
 Lauren Massa (MS 1995, Prof. Hodges)

Undergraduate student employees:

Tom Muller	1982 – 1984	Eric Ng	1990 – 1991
James Hopkin	1987 – 1989	Vadim Gutnik	1991 – 1993
Alex West	1987 – 1988	Paul Krewin	1997 – 1999
Adhi Gaduh	1988 – 1989	Jim Dukhovny	1998 – 2000

Microlab Computer Staff:

David Mudie, P/A III	1987 – 1989	T. K. Chen, PA III	2001 – 2005
Lauren Massa, P/A III	1989 – 1991	Ferenc Varju, P/A III	2002 – 2003
Mark Kraitchman, P/A III	1991 – 1997	Eniko Seen, P/A III	2005 – 2007
C. Hylands, P/A III	1991 – 1993	Changrui Yin, A/P 3	2005 – 2010
David Mudie, P/A III	1993 – 1999	Olek Proskurovski, A/P 4	2006 – 2010
Tim Duncan, P/A III	1998 – 2005	Susan Calico, P/A II	2008 – 2010
Todd Merport, A/P 4	2001 – 2010	M. Martin, R&D Eng. 2	2009 – 2010

Computer Staff transferred to the NanoLab in 2009-2010:

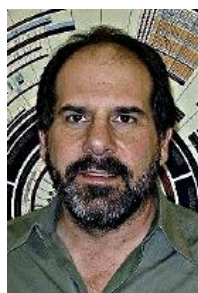

Todd Merport
A/P 4
9 years



Olek Proskurovski
A/P 4
4 years



Changrui Yin
A/P 3
5 years



Michael Martin
R&D Eng. 2
1 year

Staff Development

Staff activities and responsibilities in the Microlab could be best illustrated by intersecting circles, as shown in Fig. 56. None of the groups were independent of the others and actions by each group affected the work of the others, ultimately, the work of the students.

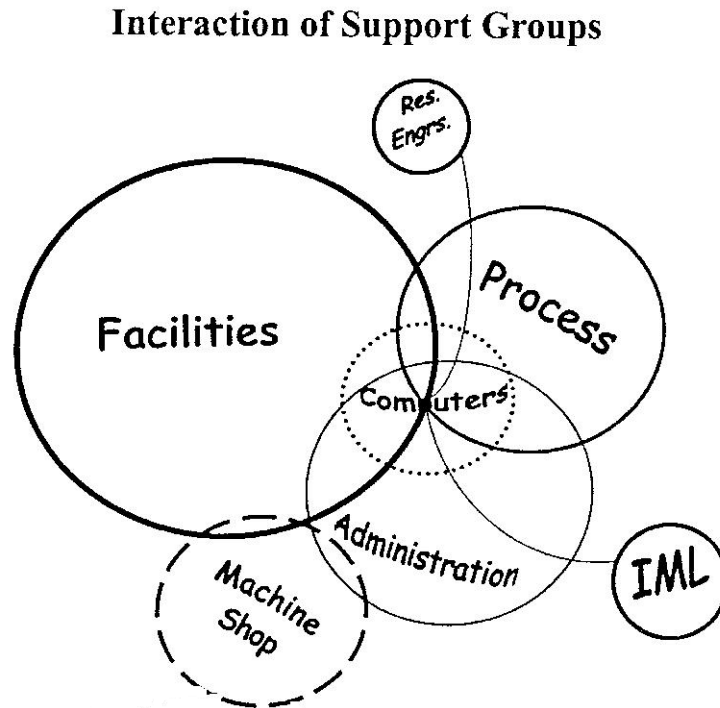

Fig. 56. Interaction of Microlab support groups.

Analysis of Staff Allocation and Action

Soon after the Microlab came under new management in 1987, all areas of the operation were reviewed to find the weak points and to identify needed improvements. In an effort to ameliorate the budget problems, a great deal of time was devoted to examining staff allocation. It was obvious that with employee salaries and benefits comprising about half of the budget, this expenditure had to be cut if the lab was going to make a dent in the deficit. (See Fig. 69 in the VI. *Finances* section, page 82.)

First, the process development engineering position K. Voros vacated was not filled; then, one of the two overlapping Principal Electronics Technician positions was eliminated. The work load was redistributed and the efficiency of the operation was increased by cross-training. By 1988 the Microlab had a balanced budget – at the expense of cutting out process development work. However, with growing membership the activities of the process staff became increasingly important; a process supervisory position was created and the role of the process staff was formalized. (Fig. 57 is a staff photo from 1990.)

Microlab management encouraged staff to plan their own career and avail themselves of educational opportunities to develop. UCB had an on and off education reimbursement program, depending on the budget, which was extensively utilized for employee development.



Fig. 57. Microlab staff photo from 1990.

L-R front row: Evan Stateler, Kim Chan, Richard Hsu, Debra Hebert, Mario Lizardo, Susan Kellogg-Smith, James Parrish, Katalin Voros
Second row: Bob Hamilton, Robert Norman, Dave Hebert, Rosemary Spivey, Tariq Haniff, Marilyn Kushner, Phill Guillory, Lauren Massa

To create a cohesive staff group, management invested early on a concentrated effort in developing awareness of several basic principles, essential for the well-being of the Microlab and its staff. These ideas were simple, clear and concise and formed the basic tenets of the operation:

- ❖ The Microlab provides a service for the students and PIs, staff is here because of them and not the other way around.
- ❖ **KEEP MACHINERY UP!** Staff needs to do their best to keep the lab open and machinery working, so that users can come in at any time and do their work successfully.
- ❖ Lab member researchers are our “customers”, the basis of our support. They provide the lab's income through the recharge system, and provide us our jobs.
- ❖ Microlab staff has the talent and skills needed to maintain equipment fully, with an absolute minimum of outside service. This requires that everyone pull their own weight and cooperate with one another.

- ❖ A certain amount of discipline is indispensable in a smoothly working unit. This must come from the members of the group, rather than from enforcement by supervisors. If everyone behaves responsibly, starting with arriving at work on time and keeping breaks to proper lengths, doing one's work conscientiously, and caring for the well-being of the unit, life will be much more pleasant for everyone.
- ❖ Everyone's job is equally important in the Microlab, and everyone's work reflects on the performance of the whole group. Respect for each other's work and a positive attitude towards the group effort make a pleasant work environment for all.
- ❖ Everyone represents the whole unit in dealing with students, professors or outside groups, and what kind of report card Microlab staff is getting, depends on all.
- ❖ Keeping communication lines open and taking care of personnel problems in a timely manner is a priority of management.

The above ideas were developed and discussed during regular monthly staff meetings; at weekly supervisors' meetings with individual staff members; in private discussions as needed, and in annual performance evaluations. Communications often occurred through computer messages or circulating relevant information in hard copy. Management made a point of distributing good news, and positive comments from within EECS/ERL, or from outside, immediately. Celebration of special occasions such as employment anniversaries, were helpful in fostering group spirit. The Christmas Potluck, and the May Rose Show became traditions; also, summer barbecues were popular for several years. Fig. 58 is a staff photo from 2006.



Fig. 58. Microlab staff photo from 2006. (By Peg Skorpinski.)

L-R front row: Eniko Seen, Madeleine Leullier, Adrienne Ruff;
 Second row: Kim Chan, Rosemary Spivey, Marilyn Kushner,
 Katalin Voros, Nancy Peshette, Susan Kellogg-Smith;
 Back row: Todd Merport, Sia Parsa, Bryan McNeil, Jimmy Chang, Evan Stateler,
 Phill Guillory, Joe Donnelly, Changrui Yin, Bob Connelly, Danny Pestal, George Vida,
 Mike Linan, Bill Flounders, Bob Hamilton, Daniel Bucher, David Lo, Matt Wasilik

Microfabrication Laboratory Staff Organizational Chart

January 2010

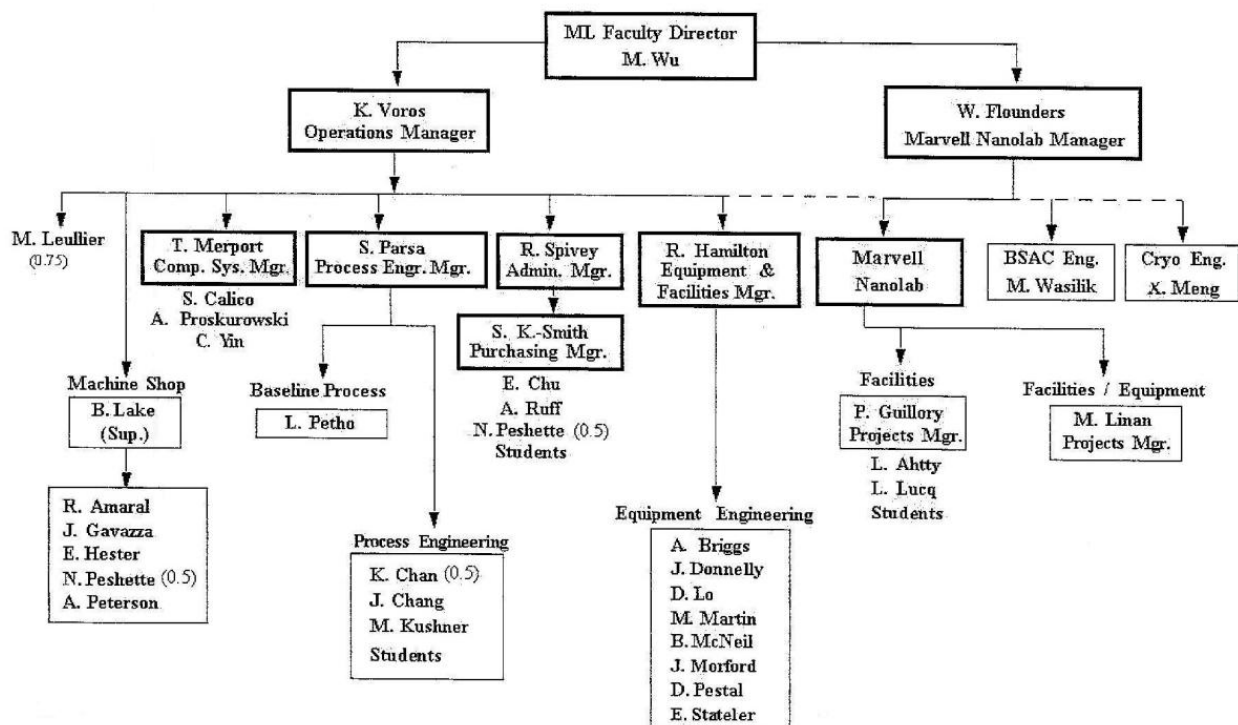

Fig. 59. Microlab staff organizational chart in Jan 2010,
just before moving to the Marvell NanoLab.

The final staff organizational chart, just before the move to the NanoLab, is shown in Fig. 59. It shows facilities engineering under NanoLab Management already, working on site preparation and utilities fit-up, before any equipment move.

Microlab management was active in participating in the various departmental and campus award programs, by recognizing and nominating staff for outstanding performance. During the 28 years of the Microlab 69 awards were presented to its staff, listed on the Staff page of the Microlab Archive web portal, <http://microlab.berkeley.edu/people/staffawards.html>.

Most notably, the following received the coveted departmental Wil Zeilinger Staff Excellence Award: Marilyn Kushner (2010), Benjamin Lake (2006), Xiaofan Meng (2003), James Parrish (2001), Phill Guillory (1997), Rosemary Spivey (1996), Bob Hamilton (1993).

Recipients of the Berkeley Staff Assembly's Certificate of Excellence in Management were: Siavash Parsa (2009), Rosemary Spivey (2004), Bob Hamilton (1996, 2000), and Katalin Voros (1995, 2001).

6. Safety

The question of safety, from both occupational and environmental points of view, was constantly being addressed and kept in the forefront in the Microlab. The following programs illustrate management's commitment to safety:

- ❖ All students, staff and visiting scientists who work in the lab were required to take a lab orientation course, a major part of which concerned safety education. During this course the newcomers were instructed by staff on the safety procedures to be used in the lab, *The Chemical Hygiene Plan*, the equipment that is available to exercise safety, and where further information can be obtained. All lab members were required to wear safety glasses at all times in the lab, and in addition, that they wear a face shield, acid resistant gloves and apron when handling chemicals. This rule was enforced by the staff of the Microlab.
- ❖ Lab members were also instructed in the *Injury and Illness Prevention Program (IIPP)*, an EH&S mandated building safety and emergency plan. This was the department's central program for creating a safe and healthful work environment in Cory Hall, where the Microlab was located.
- ❖ The Microlab followed the rules mandated by the Campus Office of Environmental Health and Safety (EH&S) and relied on them to provide "*guidance and services to the campus community that promote health, safety, and environmental stewardship.*" EH&S inspected the Microlab regularly, after which management reviewed their observations and took corrective actions. Removal of hazardous waste was provided by the office of EHE&S, on a recharge basis.
- ❖ Physicians from the Center for Occupational and Environmental Health visited the Microlab's facilities regularly, as part of their efforts to educate peers through seminars and continuing education courses. They used the lab to demonstrate semiconductor industry safety practices and had several research projects conducted in the lab.

The Microlab had a firm policy on areas of service that had a high risk associated with them.

- ❖ Electrical wiring was done only by staff, to California Electrical Code standards.
- ❖ Gas cylinders were changed by staff trained in cylinder safety. Cylinders were always chained and toxic and corrosive cylinders were operated in vented safety gas cabinets. The Microlab had a self-contained breathing apparatus (SCBA) unit and two staff members were certified to use them for cylinder exchanges.
- ❖ Toxic gas monitoring was in place for both metal hydride gases and acid gases. In case of an alarm, toxic and acid gases were shut down automatically and blue alarm lights flashed for lab evacuation.
- ❖ The lab has developed its own "low center of gravity" transportation carts for chemicals, and maintained a stringent policy for chemical transport.
- ❖ Bulletins provided by vendors and bulletins from Environmental Health and Safety were routed with a sign-off sheet to staff members. Material Safety Data Sheets (MSDS) for all chemicals in the lab were kept up-to-date and made available to the lab members, both in hard copy and on-line.

New lab members had to pass an extensive written safety test before they were allowed to open an account. Compliance was ensured by yearly refresher tests and membership was revoked until the completed test was on file. This happened each year during the Microlab's February "Safety Fest Month". (See Fig. 60.)

Fig. 60. Banner above the entrance to the Microlab, calling attention to the Safety Fest Month (1993).



Input from lab members about safety, reporting violations and suggesting improvements, was encouraged continuously. On-line and anonymous options in a suggestion box were provided. A very successful suggestion was to create a safety video, illustrating proper chemical handling and safety procedures in the lab.

Thus, in 2001 lab members and Laurel Reitman, a high school physics teacher working in the Microlab as project manager during her sabbatical year, wrote and created a 20-minute video, *Hop on Board with Safety*. The Campus TV Office did the filming, editing and post production. (Cost: \$10K). The video became a hit with lab members not only because a cute bunny in a "bunny suit" was hopping around and showing proper procedures, but because a lab member who did not follow the rules, was thrown out of the lab by the manager. (See Fig. 61 and 62.)



Clips from the safety video, Hop on Board for Safety Fig. 61. Safety Bunny leading good lab members to work safely.

Fig. 62. (above) Lab Manager K. Voros and student (now professor) Michel Maharbiz (2000).

The campus Laboratory Operations & Safety Committee (LO&SC) formulates, and recommends campus policy, to the Vice Chancellor for Research, on research and instructional activities to help ensure compliance and adoption of appropriate best practices regarding the safety of students and researchers. The committee is chaired by a faculty member, who is also on the advisory board of the Vice Chancellor for Research. Committee members are invited from laboratories, campus-wide, to serve for 3-year terms. The Microlab was invited and participated in the LO&SC from 1992 until the lab closed in 2010. The following people served: K. Voros, 1992-1998; R. Hamilton, 1999-2005, A. W. Flounders, 2005-2010.

Bob Hamilton's expertise was called upon by EH&S, when a working group was formed to develop a campus-wide toxic gas handling policy, in 1994-96. He also participated in a UC system-wide semiconductor laboratory safety meeting at UC Irvine in 2001. Microlab managers and supervisors were members of the Cory Hall Safety Committee ever since the Microlab opened for research in the building.

Microlab management actively pursued safety in the lab and responded rapidly to any safety problems that they became aware of. Many of the steps implemented were new to the University 30 years ago and the Microlab was considered a model by the offices of EH&S and the Center for Occupational and Environmental Health. (Fig. 63)

Bob Hamilton was the Microlab's Safety Officer throughout the existence of the lab. It is a credit to his expert knowledge, dedicated, pro-active attitude, that there were no serious accidents in the lab ever, only minor acid-burn incidents.



Fig. 63. Campus EH&S safety logo.

VI. Finances

The Microlab was designed to become a self-supporting recharge unit, once it was fully equipped for semiconductor processing. This vision had been based on the requirements of the circuit designers and systems groups; however, by the time the lab was fully operational, with a working CMOS process in place (1987), the need disappeared. Government supported, low cost external service became available, with advanced industrial technology, way ahead of what the Microlab could provide. The primary goals of the lab, support of research and teaching, did not change, but it was clear that adjustments were needed if the users were to support the lab fully.

The Microlab's User Base

With the IC and systems business gone, management looked to the other groups for increased activity. The department had a very diverse program, from which at first device and technology development emerged as major players. However, after the Berkeley Sensor and Actuator Center (BSAC) was established in 1986 by Professors Muller and White, (soon to be joined by Professors Howe and Pisano), the *sensor* research group immediately became the lab's largest constituency and remained thus throughout the life of the Microlab. Fig. 64 illustrates the distribution of lab-use by various research groups who worked in the Microlab, during the first five years.

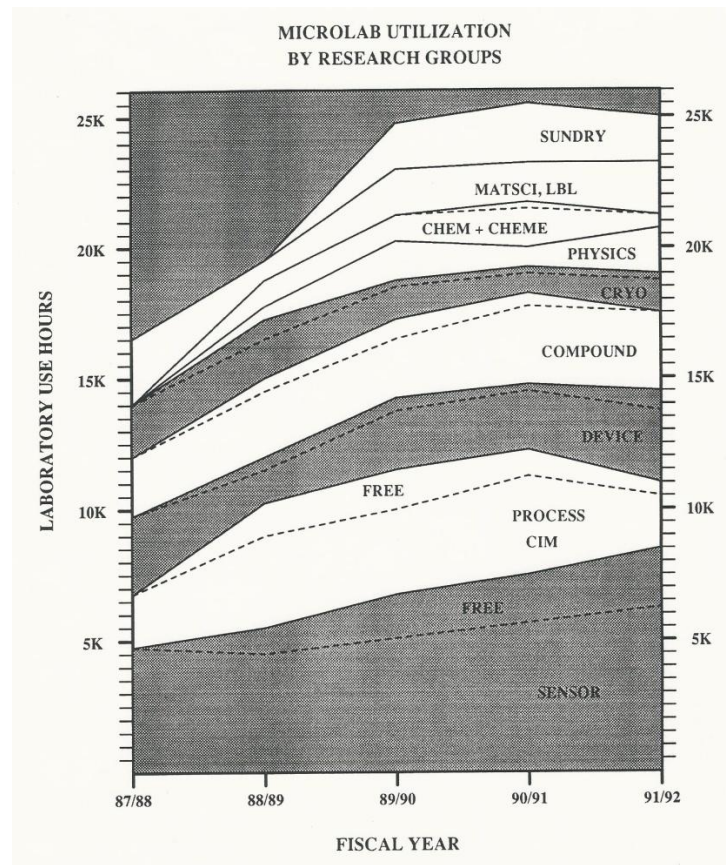

Fig. 64. Microlab utilization expressed in use-hours of research groups, 1987-1992.

The list of research groups shown in Fig. 64 remained the same throughout the years: *sensor (BSAC), process/CIM, device, compound, cryo, physics, chem/cheme, matsci, LBL, sundry*, later *meche* was added. (The *sundry* designation included other universities and non-academic entities. The latter was formalized into the Berkeley Microlab Affiliates program in 1997, requiring a membership fee.) The dashed lines in Fig. 8 indicate free lab-use hours above the \$1000 cut-off limit per student/month, meaning that no charges were incurred after the cut-off. This feature was instituted in the fee structure early on, to encourage lab-intensive projects.

Starting with the old IC lab, the Department/ERL fostered the tradition of encouraging PIs to join from all areas of semiconductor research, including compound and low temperature devices. Thus, non-silicon people were not compelled to establish their own separate labs; instead, they helped to maintain one common facility. By necessity, some equipment was always reserved for dedicated tasks, but other equipment, such as photolithography tools and analytical instruments, were shared.

To extend the user base, Microlab management looked to other departments, such as Physics, Materials Science, Chemistry/Chemical Engineering, by advising them of microfabrication technology, how to build structures to examine phenomena in their field, and by making minor adjustments to accommodate them. These efforts resulted in increasing the number of non-EE members from 33% of the total in 1990 to 62% in 2010. Although the income from these groups was proportionally less than from the rest of the research groups, only about 42% of the total (FY 2009/10), their presence was essential, beneficial, and played an important role in teaching students to embrace a cooperative spirit.

Microlab as a Recharge Center

Definition by the Berkeley Campus Recharge Committee of a recharge center:

Recharge centers are units that provide specific, ongoing services to a number of campus units or projects, and recover the cost of providing these services from the units served on a "rate basis".

<http://controller.berkeley.edu/recharge/Policies/Rechargepolicy.pdf>

Allowable costs which can be included in rate development:

- Salaries and benefits of personnel directly related to the recharge activity. (S&B)
- Supplies and expenses (S&E): reasonable general support costs, materials, services, equipment maintenance and repair costs (defined as regularly recurring disbursements to keep property in an efficient operating condition); installation charges and lease cost.
- Cost of living increases, from the California Bureau of Labor Statistics.
- Equipment depreciation and depreciation of capitalized improvements, excluding equipment purchased on federal funds. (*Depreciation is the allocation of a capital asset's cost over its useful life.*)
- Inventory. (*Inventory is defined as products for resale or the raw materials to be used in the operation.*)
- Prior year's operating surplus/loss that occurred through the normal course of business.

Unallowable costs:

- Capital equipment purchases.
- Cost of capital improvements, including renovation.

On an annual basis, Microlab recharge rates were developed for services provided in these categories:

- Access Fee (monthly)
- General Laboratory Rate (in minutes)
- Special Equipment Rate (in minutes)
- Staff Services (hourly)

Access Fee: To maintain the Microlab there were on-going expenses related to total membership. These expenses included training and continuous retraining of user groups; cost of maintaining the user's computer account; fixed-rate maintenance on facilities such as clean room environment and all disposable lab-wear.

Laboratory Rate: Basic hourly rate (charged by the minute) for use of the facility, covering a wide array of supplies and materials. The facility contained in excess of 130 pieces of equipment. Several pieces required high maintenance costs, and these costs were born by the particular users of these tools (Special Equipment Rate). The remaining pieces were used in various combinations by all users. For these it was not possible or feasible to isolate accurately the maintenance cost of any specific equipment. Therefore, staff was assigned to maintain the equipment as well as various gas, chemical, vacuum, DI water, acid disposal, and electrical systems, and the cost was shared by all users.

Special Equipment Rate: Certain equipment, such as the pattern generator/wafer steppers, plasma etchers, furnaces/LPCVD systems, scanning electron microscopes, CMP tool, had significant maintenance costs which were paid by the users of these tools. Supplies and expenses included quartz ware, parts for furnaces, LPCVD gases, mercury arc lamps, dicing blades, slurry, polishing pads, outside vendor maintenance, etc.

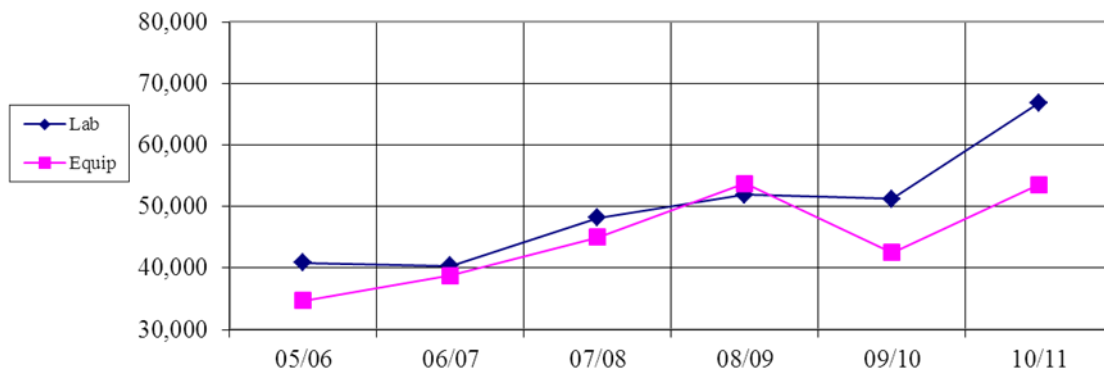

Fig. 65. Laboratory and equipment use-hours, FYs 2005/06-2010/11, used for recharge rate calculations.

Staff Services Rate: Special services such as mask making, lithographic or other special processing required the services of the process staff. Some experiments and dedicated equipment modifications required the equipment engineering staff to provide the member special services.

Rate calculations: Each rate was calculated by dividing the total estimated expenses, including S&B of maintenance and process staff assigned to the category, by the total estimated use hours of the category. (Use hours were derived from the Annual Summary of User Recharges Report – generated by BCIMS.) Fig. 65 shows an example of use-hours data for FYs 2005/06-2010/11.

Rate Approval: Recharge rate proposals were developed each April, for the next fiscal year (1 July – 30 June), and submitted to the Berkeley Campus Recharge Committee for approval. If approved the new rates became effective on 1 July. Required compliance was $\pm 10\%$ of the yearly budget. The Committee monitored fiscal performance during the year and required rate adjustment if the budget was not met. Table XII shows Microlab recharge rates over a 20 year span.

TABLE XII
MICROLAB RECHARGE RATES IN 1988, 1990, AND 2010

Microlab Recharge Rates				
	1987/88	1989/90	2009/10	20 yr % chg
Lab Access per month	57.50	74.06	88.00	19
General Lab Use per hour	12.21	21.87	39.60	81
Special Equipment per hour	12.67	21.64	35.40	64
Staff Services per hour	26.22	55.23	69.00	25

Compliance: The Microlab’s recharge account was in compliance every year for 25 years, during which time monthly membership increased from 138 to 337 (in the same facility) and the budget from \$802 thousand to \$3.2 million.

The 20-year rate of inflation between 1990 and 2010 was 76%, which can be seen in the increase in lab and equipment fees. This is the direct result of the inflation increases having been included each year in the recharge rate calculations. Income grew from \$802K to \$3.2M in the same period; in 2010 it would have been \$1.34M due to inflation, without growth. However, membership grew from 138 to 337, 144%; income in the same time grew 139%. These numbers are consistent with a well-managed recharge operation in which financial performance was monitored closely and adjusted based on actual expenses and realistic income estimates. Fig. 66 illustrates the growth of income vs. lab membership.



Fig. 66. Microlab income vs. membership, 1986-2010.

Record Keeping and Reports

One of the prerequisites of a well-run recharge operation is keeping accurate records of income and expenses. The Microlab's BCIMS software provided an outstanding accounting module, which was connected to laboratory entry and equipment activity records stored in an object-oriented database (Ingres). The ACCT module, written by David Mudie in 1987, was the first direct request by management to CIM researchers, in the effort to stabilize the lab's finances and to create a realistic recharge rate proposal.

Another key factor in maintaining a recharge operation within budget, besides knowing the numbers, is transparency. Microlab management started to submit Fiscal Year-End (FYE) results in 1988 to the Faculty-in-Charge and Department/ERL leadership; the first full financial report was published in September 1990. This practice, sending yearly FYE memoranda to PIs, continued until the lab was closed.

FYE reports included the following: summary of fiscal performance; recharge rates for the next FY; financial summary page (Expenditures: projected and actual supplies and expenses (S&E), salaries and benefits (S&B); Recharge Income: projected and actual; Carry Forward Balance; one page S&E details (65 top items); one page S&B details, including FTEs supported from non-recharge sources; one page of PI Summary, listing the top 70 in decreasing order of amount spent in the lab; statistical charts: Laboratory and Equipment Use-Hours, Lab members by Department, Income from Research Groups. The PI listing was very effective in determining priorities when multiple requests were submitted by professors for changes or for special attention to projects.

Capital Equipment

According to the Campus Recharge Rate Policy, capital equipment purchases and capital improvements, including renovation, were not allowed to be included in recharge rate calculations. Thus, obtaining equipment for new research was a challenge.

When the Microlab was created, original funding included equipment for 4" Si wafer processing. During the first two years the tool set was augmented to support CMOS technology, through additional BMA grants. (See *Financial History of the Microlab* below.) After the start-up grants were exhausted, management developed several approaches to equipment acquisition. Most of the thrust for new equipment came from the research groups, but also from maintenance considerations. When a tool became too old and/or too expensive to maintain, it was time to decommission or to replace it.

1. Receiving donations is a good way to obtain equipment; however, it is not really free. Often it is not known what condition the tool is in, what materials were used in it, and what was its process-history. Parts, control software/ hardware missing or out of date, and often the pump package did not come with the system. In spite of these disadvantages, Microlab management was on the constant look-out for donations – selectively. The goal was to obtain only specific items which were missing from the Microlab's tool set.
2. Grant proposals by research groups was another way to receive equipment. In these cases a tool was needed to do new research so the costs were justified. The condition for placing such a tool in the Microlab was that after a start-up and grace period for restricted use by the group, the tool would become available to all members. After that, equipment charges were applied to all users, including the group who bought it, and the tool was maintained by staff.
3. Equipment donation as matching fund: this was a precarious model from the Microlab's point of view. State of California research grants required that industrial partners provide some of the funding for the proposed research. Equipment companies desiring to join such grants were eager to donate equipment as their share of funding – not always the best option for the Microlab. However, there were cases when installation and start-up costs were covered, which helped the cause.
4. Joint purchases by several groups were the results of an interested PI, or the Microlab's Faculty Director, soliciting funds from all the interested groups. Usually, the Microlab was one of the contributors, in addition to assistance in researching the best tool option, negotiating, purchasing, site preparation, installation, and process characterization. Both Jim Bustillo and Bill Flounders, Microlab Technology Managers in succession, were skillful and successful in executing such deals. The Microlab's portion of the contribution came from the overhead funds generated by the lab fees of industrial members. (See *Industrial Members* below.)
5. The Microlab's equipment staff in cooperation with the staff of the Machine Shop was continuously engaged in equipment modification, upgrading and rebuilding, essentially creating new/improved machinery for the lab. This was a constant throughout the life of the Microlab; however, the 6" upgrade project (1998-2004) and the lab move (2009-200) created heightened tool building activity. More on these later.

Financial History of the Microlab

When the Microlab opened for general use in 1983, a new recharge structure was initiated, based on estimated expenses and income. Recharge rates were considerably higher than those in the old IC lab. Even at the new rates, income fell far short of expenses. Membership was below old levels and many expenditures associated with startup had to be absorbed. This was not unexpected and plans were made early by the Department to support the lab partially from donations during the critical ramp-up period.

The Berkeley Microelectronics Affiliates (BMA) program of the Department was established in 1984, to provide ongoing industrial support for research and instruction in microelectronics and CAD/CAM [5]. Each BMA company pledged an annual cash grant for a period of five years. The Microlab received from these gifts an annual support which has been gradually reduced as lab income increased. In FY 86/87 the budget included a \$194K BMA grant, which did not come from users. In FY 87/88 it was \$150K, and in FY 88/89 \$90K. Recharge rates were raised slowly during the subsidy period, which helped PIs to adjust gradually to higher lab expenses. At the end of FY 88/89, five years of BMA commitments expired. Subsidies to the Microlab were discontinued starting July 1989.

In 1983 the Microlab had an accumulated debt of \$401,186, left over from the construction of the facility. The University did not charge interest on such arrears; however, in 1987 the Campus Recharge Committee required that the Microlab start paying back the debt. In compliance, starting with FY 88/89, yearly budgets included a proposed \$50K debt recovery. With the ending of subsidies and the requirement of deficit recovery, Microlab finances were in a precarious position during the first few years.

Without subsidies, there were only two ways for the Microlab to meet the budget: increase revenues and/or decrease expenses. Increasing revenues meant that the number of lab users had to grow. Management invested a great deal of effort in this area, as discussed in the first part of this section. Besides academic members, increasing external/industrial membership provided an opportunity for development. This activity will be described under *Industrial Members* below.

Reducing expenditures meant instituting strict budgetary control procedures. These involved the following:

1. Yearly budget itemized in detail, with assigned object codes.
2. Monthly monitoring of expenditures.
3. Manager signing off on all non-standard expenditures of greater than \$100. (This was changed to \$500 and then to \$1000 later.)
4. Careful review of standard and large expenditures.
5. Periodic review and adjustment of staff allocation.
6. Full computerization of charging procedures; monitoring for discrepancies.
7. Establishment of an efficient structure for revenue collection and follow up.

The University provided, as part of the return from research contracts' overhead, in kind support in the form of electricity, air conditioning, compressed air, industrial water, recirculating cooling water; building maintenance (outside walls of the lab) and custodial service (floor cleaning inside the lab.) The value of these services was not included in the budget calculations.

Help came from several sources in the form of FTE salaries for which the Microlab did not have to pay. These were:

- ✓ The Department of EECS funded the salaries of the lab manager and a maintenance engineer for 15 years, after which the support was reduced to the manager's salary only. This was partially in lieu of the service Microlab staff provided in maintaining the undergraduate teaching lab, EE 143, Processing and Design of Integrated Circuits, in room 218 Cory. In addition, there were no charges for graduate classes held in the Microlab. Departmental support slowly diminished after 2005, as University finances began to erode and ceased after the Microlab closed its doors in Cory Hall in 2010.
- ✓ As the Microlab managed its own administration, ERL/ERSO which provided research administration support to member PIs, funded the salaries of 1-2 FTE (varying over the years) administrative staff in the Microlab. This lasted for the existence of the Microlab.
- ✓ Computer system hardware and software support was provided by the CIM research project (Professors Hodges, Rowe, and Spanos) during the first seven years of the Microlab. The Microlab hired its own systems manager in 1990 and took on the responsibility for its own "production" hardware and software, including all the servers and the database.
- ✓ Several projects and grants, such as SRC, MICRO, CNRI, SMART, FLCC, IMPACT, CITRIS, etc. provided various amounts of funding over the years, for equipment and process engineering staff. The FTE support depended on the extent of involvement and the type of platform the Microlab provided for the research projects.
- ✓ The total support the Microlab received from the above sources averaged at about 5 FTEs per year, from 1989-2010. This support was always listed and acknowledged in the FYE reports. (Engineers and/or post docs employed by research groups directly, for their own projects, were not included in these listings.)

With careful fiscal management and with the assistance described above, it took 10 years for the Microlab to pay off its obligation. There was a celebration. See Fig. 67 below.



Fig. 67. Mortgage burning celebration, 20 August 1997.

Industrial Members (BMLA)

The Microlab, since its inception, has served as a place for technical collaboration with the industrial community. Opportunities evolved through lab alumni who requested lab access, to continue their experiments and development work while employed by a company. Also there were those who started up their own small firm and needed a facility work in. They were welcomed not only because of the lab fees they paid but also because this activity enhanced the role of the Microlab as a start-up incubator.

In 1997, under the leadership of Professor Spanos, Microlab Faculty Director, the *Berkeley Microlab Affiliates* (BMLA) program was started, to formalize the relationship with industrial partners and users of the lab. A membership fee of \$15K/year/employee was introduced, which was registered as a gift and not overheaded by the University. (A 7% gift processing fee was assessed.) Standard laboratory fees applied, to which University overhead was added as a separate line item in invoicing. Membership fees and lab-use overhead fees, according to Recharge Policy, were retained by the Microlab and provided crucial funding for development. Details of the BMLA program can be seen on the Microlab's archive portal, <http://microlab.berkeley.edu/text/bmla.html>.

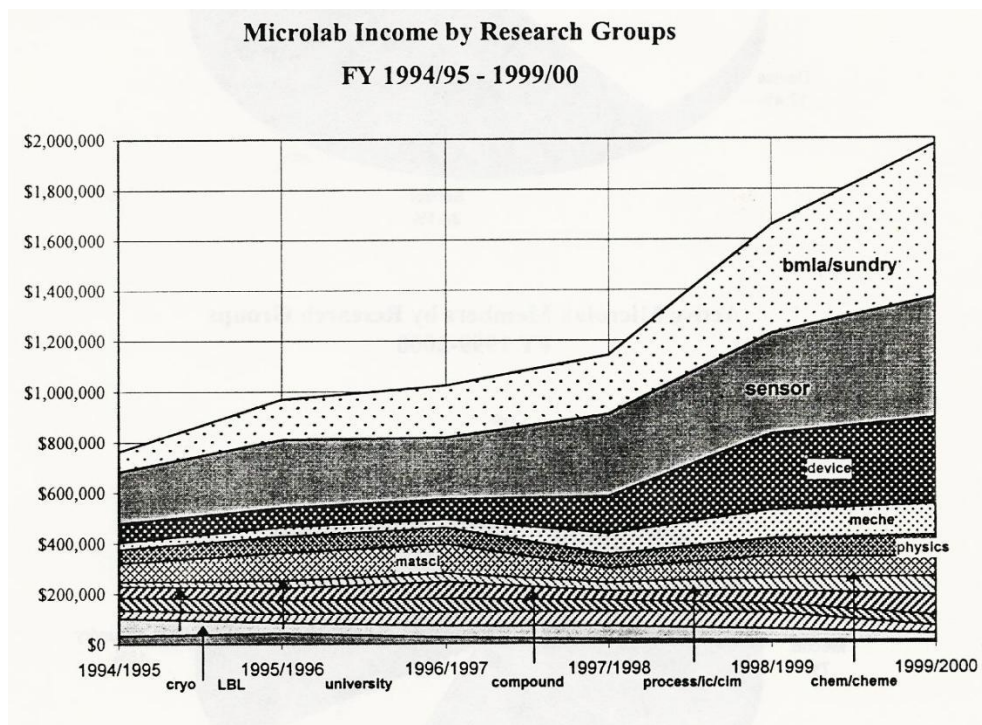

Fig. 68. Microlab income by research groups, 1994-2000.

The BMLA program was successful from the start. Each applicant's project was reviewed for compatibility and possible impact on lab utilization. If the project fit and did not cause undue burden on students' research, the company was allowed to join. The number of companies, mostly small start-ups, varied between 10 and 25 over the years. On the average, about 20% of the Microlab's income was generated from BMLA companies. Management established a limit of 30% of total income, which came close only twice during the 15 years of the program. Fig. 68 illustrates income from research groups, 1994-2000. FY 1999/2000 and FY 2000/2001 had the two highest BMLA income. At the close of the Microlab it was 15%.

Funding Laboratory Development

The numbers in Fig. 68 did not include industrial membership fees and overhead. Those were accumulated in separate funds and set aside for laboratory development. It is to the credit of the industrial members of the Microlab that the lab was able to execute two major development projects, upgrading the CMOS/MEMS tool set to handle 6" diameter silicon wafers, and the move and conversion of the Microlab into the new Marvell NanoLab.

Six-Inch Upgrade (1998-2004)

Ten years after Microlab was fully developed to support CMOS and MEMS research, it needed major upgrading of equipment and utilities to keep up with the advances in industry. There was no available funding from anywhere; thus, Microlab management developed a three-phase plan, based on discussions with member PIs and industrial affiliate members.

Phase I (1998-2000) included facilities/utilities preparation/upgrade and the 6" lithography module. The impetus for this phase was the arrival of a newly refurbished ASML 4X stepper, (5500/90) obtained through a UC SMART matching grant.

Phase II (2000-2004) included construction of satellite labs on the first floor of Cory Hall, to accommodate a PECVD, a CMP tool, and a Novellus thin films system; furnaces and LPCVD systems, etchers, and MEMS-specific tool conversions. Equipment came in partially as matching grants, partially by purchase from Microlab funds.

Phase III (2001-2010) became the quest for a new lab. CITRIS, a four-campus institution was formed and the headquarters building at Berkeley was approved in 2001. Plans included a new lab, the Marvell NanoLab. Phase III ended when the Microlab closed its doors in Cory Hall.

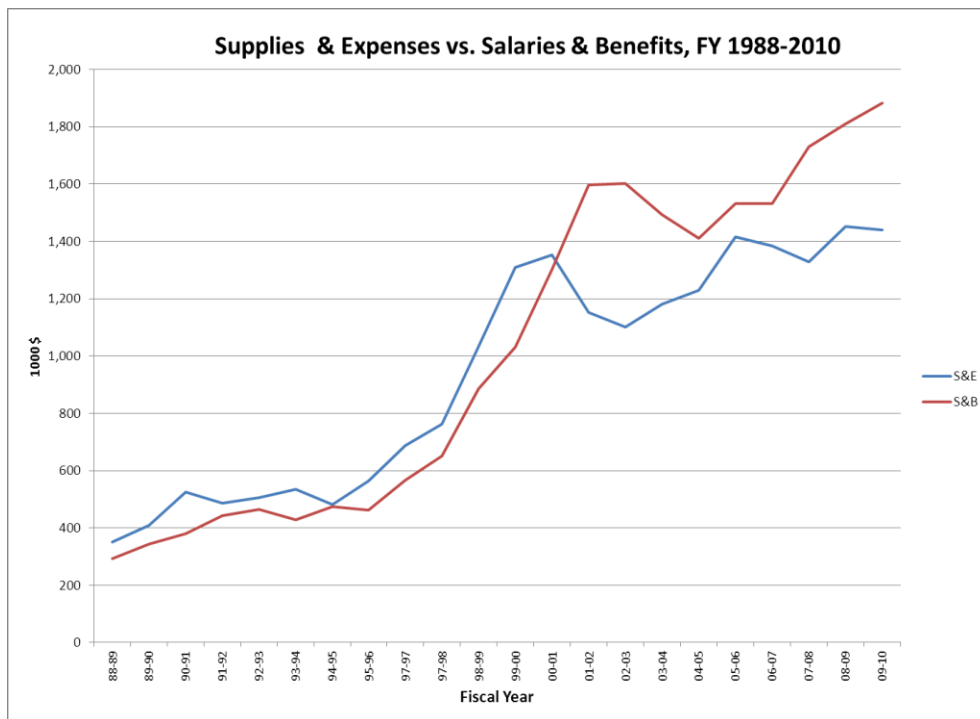

Fig. 69. Supplies & Expenses vs. Salaries & Benefits portions of the budget, 1998-2010.

Fig. 69 illustrates the increase of S&E and S&B during the 1990s, due to the dramatic increase in membership during the same period. During Phase II of the 6" upgrade project, with the addition of staff, S&B expenses increased and remained at this high level until the closing of the Microlab. Increased staffing was necessitated by the additional work load of the upgrade and the lab move, both executed with in-house talent. Project leaders were the Microlab's Technology Managers, Jim Bustillo (1998-2000) and Bill Flounders (2000-2004). The 6" upgrade provided the opportunity for Dr. Flounders to segue into participating in the design of the new lab and to formulate plans for developing staff for the move.

A detailed report, including finances and project time line, was submitted to the Faculty Director of the Microlab and to the ERL Director, in December 2004. The upgrade was accomplished in 6 years, without shutting the lab down, except for the tools during rebuild. The Microlab's share of the costs was \$2.9 million, supported by industrial membership fees, surcharges, operations, gifts and faculty contributions. Research groups financed additional staff at a total cost of \$1M. Installation costs provided by research equipment grants were \$1.6M. The total cost of the upgrade was \$5.5M. Recorded value of donated equipment was \$7M. (Final report at <http://microlab.berkeley.edu/text/6inchup/finalrpt.html>)

By the time the 6" upgrade was completed in 2004 the Microlab was crowded with equipment and students. In 1996 lab usage reached 200 members/month, which was the estimated maximum for efficient operations. (It reached 350 before the new lab became a reality.) One of the students expressed the opinion of many, by presenting management with the framed cartoon depicted in Fig. 70.

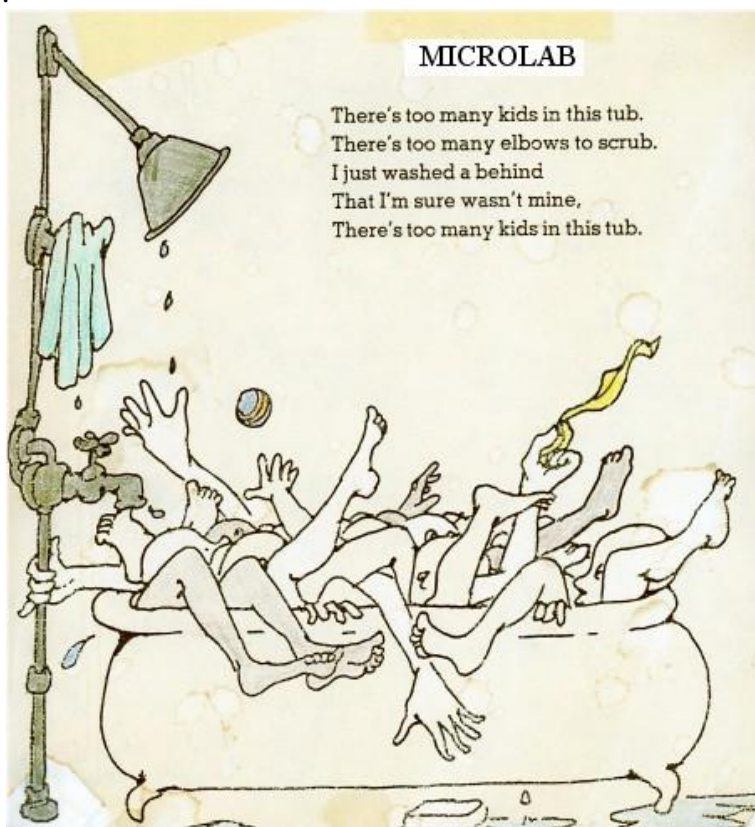

Fig. 70. Lab members' complaint. Present from Andrea Franke, 2000.

Move of the Microlab into the New Marvell NanoLab

The new CITRIS Headquarters, Sutardja Dai Hall, opened in 2009, eight years after the approval. During this time the project went through several value engineering steps, each cutting more and more capabilities of the lab. NanoLab fit-up and Microlab decommissioning, both included in the original budget, were the first to go. Sinks and gas lines were next, and a host of lesser items. Fig. 71 and 72 show the bare new lab ready for fit-up.



Fig. 71. NanoLab ready for move-in.



Fig. 72. W. Flounders discussing tool siting.

Building funding problems and construction delays provided Microlab management an opportunity to develop a sound financial plan and strategies for the move. Upon consultation with the Campus Recharge Committee and approval, the recharge account remained the same, regardless of the location. Based on the demonstrated fiscal responsibility of the Microlab, in compliance for 22 fiscal years, the account was allowed to incur a deficit in the equipment reserve fund, to be paid back in three years.

Cost of the move was \$3.2M, covered by meticulous savings (\$1.1M) of industrial membership fees and surcharges, after the 6" upgrade was completed; fundraising by the NanoLab (\$200K); funds from other sources (PIs, ERSO, CITRIS, and Lam Research donations: \$1.1M), and the Microlab/NanoLab equipment depreciation fund (\$800K), which incurred a deficit of \$416,252. Because lab use remained high during the move (Fig. 73) and increased somewhat after the transfer was completed, the NanoLab was able to meet its scheduled obligation to the reserve fund at the end of FY 2010/11.

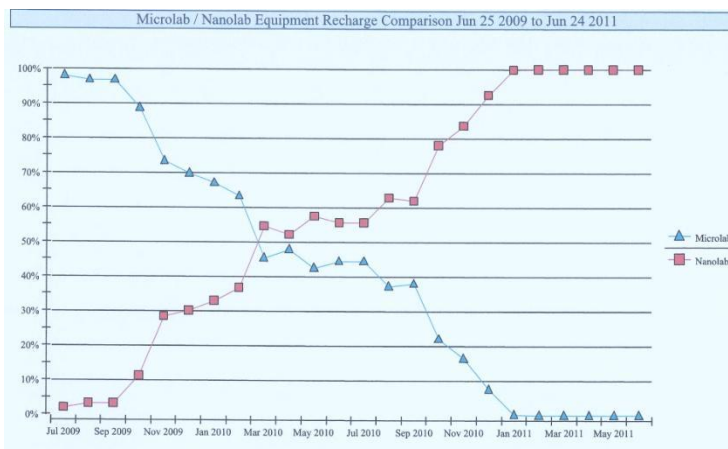

Fig. 73. Microlab/Nanolab equipment use-time comparison during transfer, July 2009 to May 2011.

VII. Computer Information and Management System

Computers in the Microlab were ubiquitous from the start, as part of a major research project, Computer Integrated Manufacturing, CIM. Planning and development started in 1982 by Professors D. Hodges and L. Rowe of EECS and R. Glassey of IEOR and their graduate students. Professor C. Spanos joined in 1988. The information system was to be modular, flexible, portable, reliable, and amenable to future changes and upgrades – attributes found missing in a thorough study of commercially available information systems aimed at the microelectronics manufacturing market. [4]

The original system employed standard, off-the shelf computer technology of the day (1983), VAX (DEC) CPU (called Merlin), workstations (Microvax II and SUN), Berkeley UNIX operating system, Ingres Relational Database; RS-232, SECS, Ethernet networking, and Z-29 terminals. (The last of these was retired 20 years later, in 2003. See: <http://microlab.berkeley.edu/history/Z29Retirem.jpg>.) The software system was built largely of standard UNIX utilities, written in C++, with the addition of a menu driven command interpreter. A novel design which enabled users to walk up to any terminal in the lab and continue where they left off previously, at another terminal, was a daemon program called Pluto.

System deployment in the Microlab began at the outset, when communication lines and terminals were installed along with processing equipment. By request of management to the CIM research group, equipment control and reservations – in conjunction with the accounting module – had the highest priority on the agenda. Graduate students wrote the programs and provided assistance with installation, as can be seen in Fig. 74.

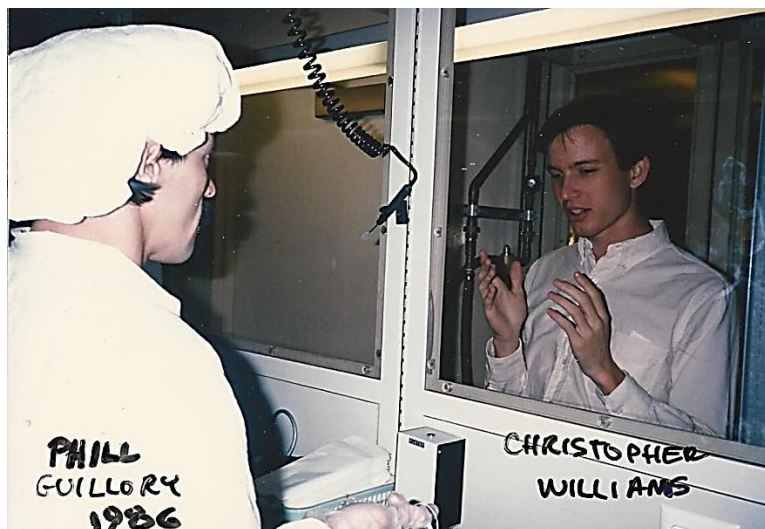

Fig. 74. Microlab technician and graduate student (in the Taurus chase) discussing wiring configuration of the equipment control system. (Taurus box on the wall.)

Computerization of the Microlab was fully supported by the CIM research group for eight years, until 1990. This included providing and maintaining the servers, terminals and other peripherals in the lab, software design and development by graduate students and CIM staff, assistance with deployment, backups and upgrades. Student projects within the CIM program included designing of expert systems for processing; process modeling, characterization and diagnosis; equipment monitoring, diagnosis and control; facilities layout and utilities monitoring programs; speech input and synthesis. (See References 12, 13, 16, 18, 19, 21, 23, 24, 25, 27, 29, 32, 41.)

Microlab staff was very much involved with CIM projects, starting with suggestions of areas to explore, installing sensors, modifying hardware to allow for computer communication and control, testing of software and reporting results. Besides allotting staff time to support these projects, CIM work had to be coordinated with other researchers in the lab to avoid disasters. For example, when the computer controlling the furnaces was modified to allow for SECS communication with the lab computers, the whole system had to be shut down, placing everyone on hold. When it came up, all old programs had to be modified to run with the new hardware. All changes, no matter how well planned, were disruptive, but lab members regarded these as part of another group's research project and were willing to accept the disruptions in good spirit.

In 1990, research (Merlin) and "production" were gradually separated and the Microlab became responsible for maintaining its own system (Argon for running the lab and Radon for CIM development). From then on the Microlab's budget included computer staff, database, software and hardware maintenance and upgrade expenses. Fig. 75 shows the Microlab's computer system in 1992.

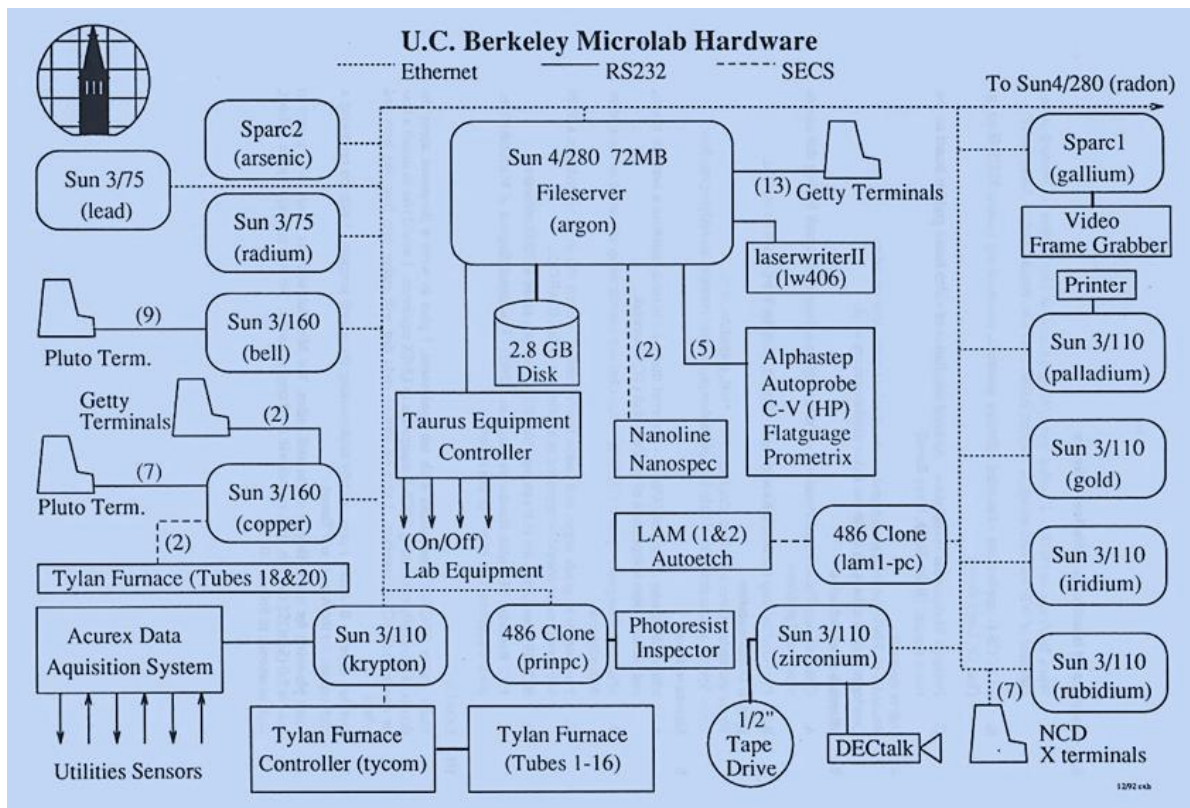
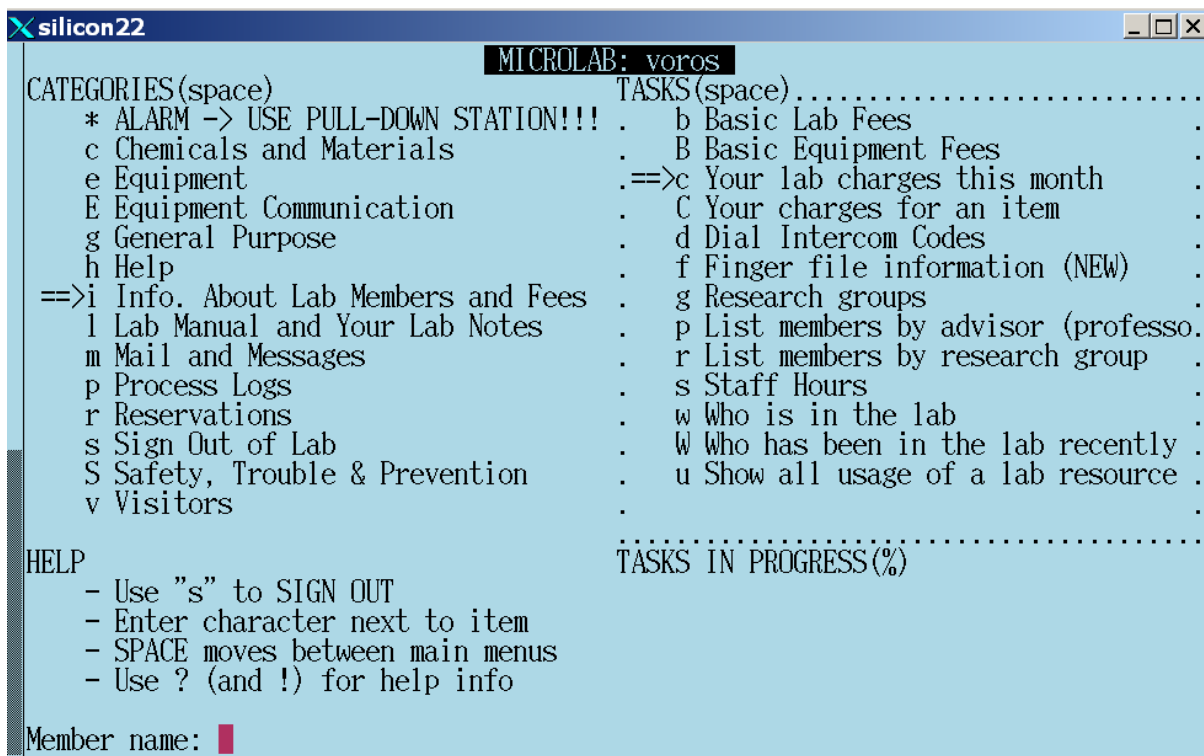

Fig. 75. The Microlab's computer hardware configuration in 1992 (C. Hylands).

System Description

Lauren Massa-Lochridge's Master's Degree report, *BCIMS: The Berkeley Computer Integrated Manufacturing System* [32], presents an exhaustive, technical description of the Microlab's computer system. This short overview will give an idea of how, and for what, was the system used by lab members and staff.

Upon login the user was presented with the WAND, an alphanumeric menu, with a CATEGORIES field on the left side, and a TASKS field on the right side. By entering a letter on the key board, the sub-menu for that category was shown on the right side. Hitting the space bar switched the "window" (dotted outline) from left to right (and back). The example in Fig. 3, in the V. 3. *Equipment* section of this report, illustrates the equipment enabling action on the WAND; Fig. 76 is an example of how a lab member submitted an inquiry about lab fees.



```
silicon22 MICROLAB: voros
CATEGORIES(space)          TASKS(space).....
* ALARM -> USE PULL-DOWN STATION!!! . b Basic Lab Fees .
c Chemicals and Materials . B Basic Equipment Fees .
e Equipment .=>c Your lab charges this month .
E Equipment Communication . C Your charges for an item .
g General Purpose . d Dial Intercom Codes .
h Help . f Finger file information (NEW) .
=>i Info. About Lab Members and Fees . g Research groups .
l Lab Manual and Your Lab Notes . p List members by advisor (professo.
m Mail and Messages . r List members by research group .
p Process Logs . s Staff Hours .
r Reservations . w Who is in the lab .
s Sign Out of Lab . W Who has been in the lab recently .
S Safety, Trouble & Prevention . u Show all usage of a lab resource .
v Visitors .
HELP          TASKS IN PROGRESS(%)
- Use "s" to SIGN OUT
- Enter character next to item
- SPACE moves between main menus
- Use ? (and !) for help info
Member name: █
```

Fig. 76. By typing in a login name, a lab member could obtain her/his charges for the month.

After typing in the login name the lab member's activity data was retrieved from the database and displayed on the screen. This included login/logout times, equipment enable/disable times, with the name of the tool, and calculated charges for the session. All charges were summarized for the month.

Use of the WAND was intuitive and students quickly became familiar with it. Some TASKS required text entry, such as equipment problem reports, using the *vi* editor of UNIX. This was no problem until the mid-1990s, when graphical user interfaces became the norm and lab members started grumbling about the old fashioned ASCII command interpreter. Graphics terminals

replaced the Z-29s gradually and static information was moved to the Microlab's website. However, the WAND remained the interface for the interactive modules until the Microlab closed in 2010.

A similar interface, STAFF, provided management with information and options to update files and the database. The Accounting module produced summary reports in various forms; individual modules could be turned off and on; Equipment Comments made possible to add information which would appear to the user upon enabling a tool, and/or prompted for process parameters upon disabling the tool. The Equipment CATEGORY TASKS included the capability of adding new equipment, prompting for required utilities, gases and pumps, etc. information; equipment-use information (who, when, how long); locking/unlocking equipment to prevent enabling during repair for instance.

The Equipment Communication TASK enabled data dumping from tools that had electronic controls which allowed it. Maintenance selections included updating the problem report/repair module, access to the Utilities database, the Pumps database, and the maintenance calendar. The original STAFF interface, designed by graduate students, was expanded by Microlab staff and built up to encompass all aspects of lab management; thus, later it was renamed LAB MANAGEMENT. Fig. 77 shows how staff could add a qualified user's name to the tool's list, after the student passed the qualification test. After this the new user could enable and use the tool independently. The reservation program also checked the tool's qualified users list before allowing the user to make a reservation.

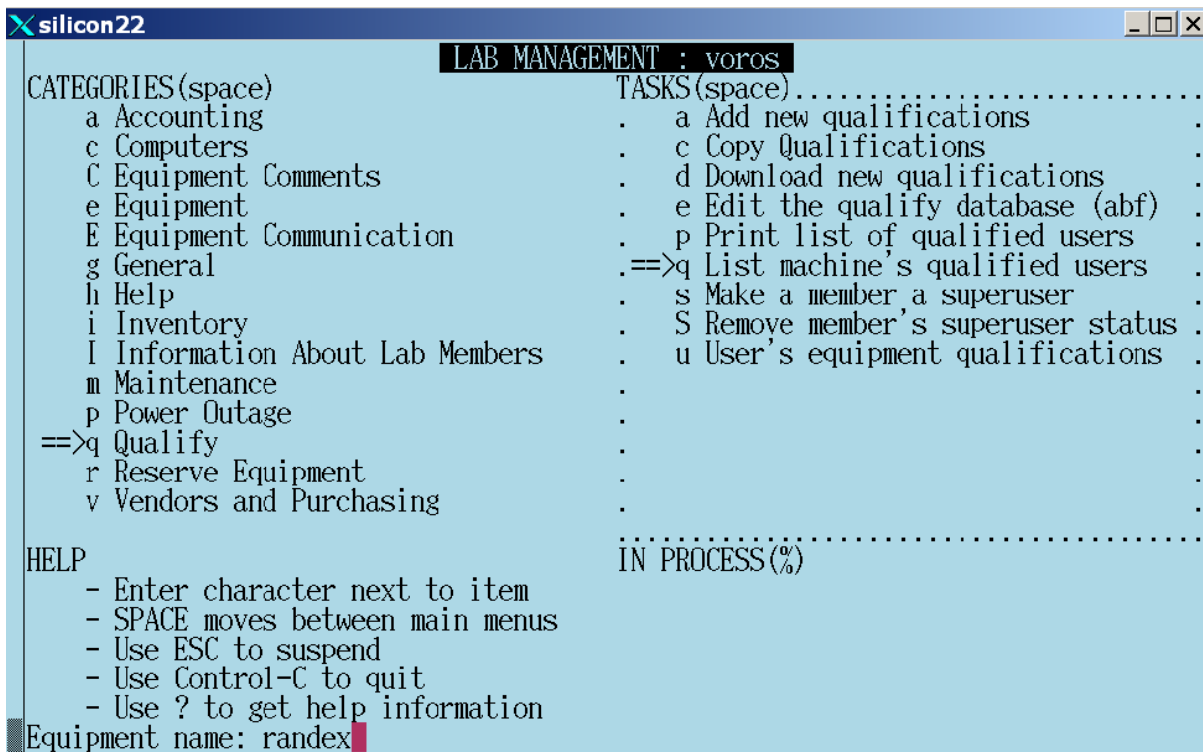

Fig. 77. Lab Management interface of BCIMS.

The original WAND and STAFF interfaces, with the program modules and the database behind them, collectively called BCIMS, enabled full control of laboratory operations. BCIMS was a work in progress throughout the life of the Microlab. During the first 10 years new capabilities were added, as lab management refined and redefined requirements in tuning lab operations. Tremendous changes in computer technology in the following decades required continuous upgrades of both hardware and software. However, the original design stood the test of time extremely well and enabled, in no small way, the successful management of the Microlab's recharge operation.

Development and Upgrades

In 1995 Microlab leadership participated in establishing an informal organization of academic laboratories, the *Labnetwork*. Among the common issues discussed were how to keep the facilities current and how to share development of a state-of-the art laboratory information and management system. In 1996 the Laboratory Software Project was initiated with the participation of the Stanford, MIT, and Berkeley labs. (www-mtl.mit.edu/labnetwork)

Joint meetings and design development went on slowly for two years, agreeing on the Java software platform (by Sun Microsystems), Common Object Request Broker Architecture (CORBA), and Interactive Data Language (IDL) standards. By 1998 Stanford and MIT were under pressure to deploy a new system because of the looming Y2K bug; the Microlab, having gradually upgraded its systems along the way, was not. Stanford and MIT were able to develop a basic new system, called CORAL²⁵, in time for Y2K. Berkeley continued with BCIMS and replaced several modules with new ones, based on up-to-date technology, as part of its 6th Upgrade project.

Microlab top priorities included the accounting module in conjunction with the equipment control, while this was a secondary concern to the others. After testing the CORAL prototype, Microlab designers Todd Merport and Ferenc Varju, felt that the Microlab would be best served by a more local-specific set of tools than a general system tailored to fit Berkeley's environment. Also, the CORAL design was not flexible enough to allow for easy changes. Thus, in 2002 Berkeley resigned from the joint project, to develop a more targeted, therefore simpler, system. This decision also helped CORAL developers by not having to be concerned with three different priorities lists, only two.

The joint project, however, resulted in several good developments for the Microlab. To be able to beta-test CORAL, the lab's main server (Argon, SunOS) had to be upgraded to the Solaris platform (server renamed Silicon). The database was upgraded to Ingres II, which supported Java and extended graphical user interfaces (GUI). Finally, the 20-year old, ailing and discontinued Taurus equipment access control computer, was replaced with a new system, designed for Stanford by Walker Manufacturing. It was named the WIS (for Walker Interlock System).

²⁵ Common Object Representation for Academic Laboratories

The **new equipment control system, WIS**, fully deployed by 2001, was in place until the Microlab closed. The WIS consisted of interlock control driver boards (25 channels per card) in a standard PC with Linux OS, and two types of interlock boxes, low level and power, depending on the application. Interlock boxes were connected to the WIS server by dedicated wiring. In case of dispersed equipment, such as those located in the Microlab's satellite labs, additional WIS servers were installed, which were connected to the Microlab's host computer Silicon (and the database) through the local area network. The equipment control process, from the users' point of view, enable/disable, accounting, remained the same, with new hardware behind it.

Graphics terminals (flat panel) started to become the norm at about this time and were introduced in the Microlab gradually. Tim Duncan designed a new terminal server system, based on Windows 2000, to replace the original, Pluto. The Common and Personal Environment, **CAPE**, application was running on the Microlab's local area network, and provided users with a common PC environment with several windows, one of them an Xterm window for the original Wand character-based interface. (Fig. 78.) In addition, CAPE provided access for lab members, inside the lab, to the internet. CAPE retained the ability of users to continue where they left off previously, at another terminal. It was fully deployed in the Microlab and its satellites in 2001. (Fig. 79 and 80.)

With this, the integration of PC/Windows workstations into the Sun/Unix environment, was completed. Fig. 82 and 83 show the computer infrastructure in 2007, after the upgrades.

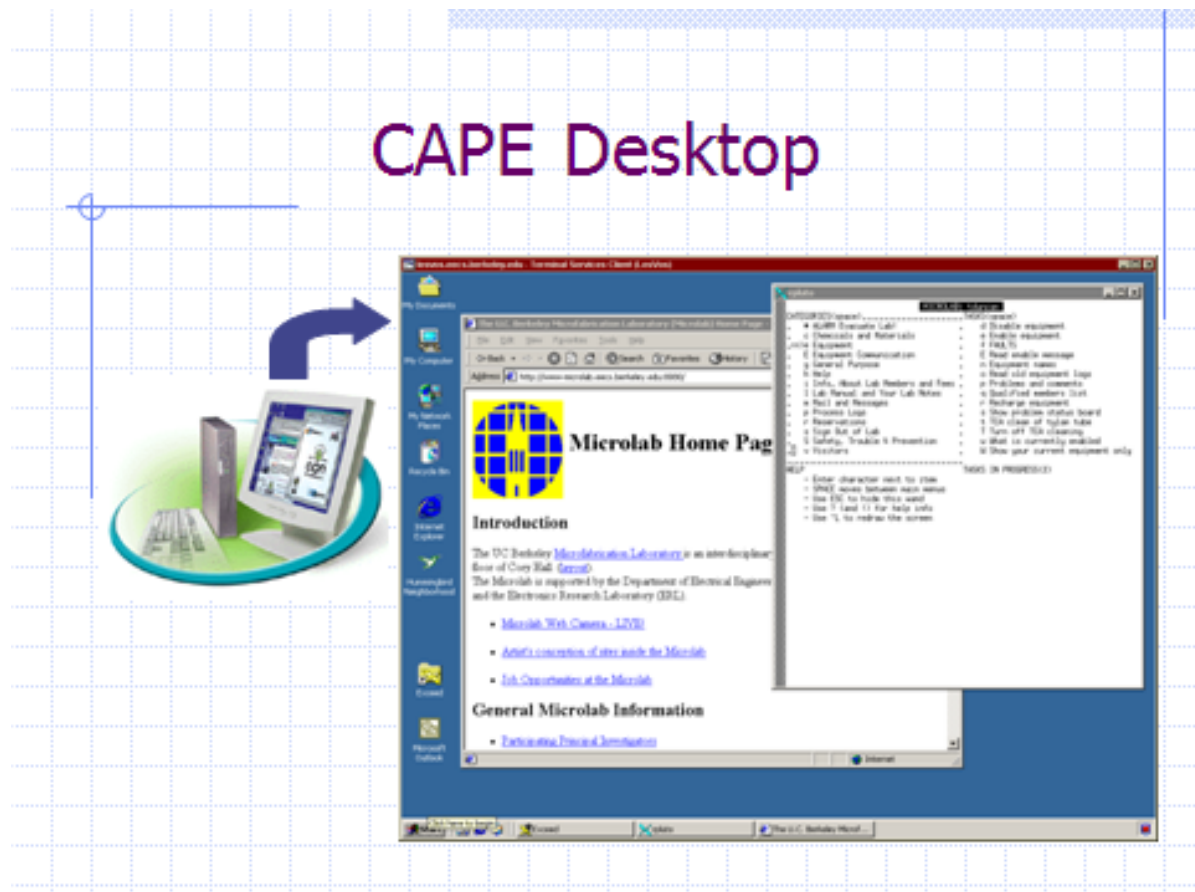

Fig. 78. CAPE terminal in the Microlab (Tim Duncan, 2001).



Fig. 79. Graduate student Mark Hadley enabling a tool on a Pluto terminal (1995).



Fig. 80. Graduate student Adam Fennimore using the CAPE terminal next to a process tool, with its own computer (2003).

With the 6" equipment upgrade and the ensuing process development enabled by the new tools, specialty gas cylinder management became difficult. The **Microlab Gas Database** was the next item that Todd Merport redeveloped on a modern platform (2003). The original Parts and Inventory database, accessible by an interactive Objects-by-Forms system on STAFF, also included a Gas Manager. The new program utilized Microsoft Access on an SQL (Structured Query Language) server, to present a web-based interface for the viewer and interactive access to the inventory manager. This system is still being used today.

RUMS, the Resource Utilization Management System [41], described in detail in section *V. Operations, Monitoring Utilities*, was also the direct descendent of the first facilities monitoring software, BLIMP, the Berkeley Laboratory Infrastructure Monitoring Program [18]. Again, the new version, based on the latest (2003) computer technology, kept many of the features that had proved useful, over fifteen years of service, but also added many features afforded by modern technology.

RUMS employed a National Instruments data acquisition card in a dedicated PC with Windows 2000 platform, connected by Ethernet to the lab's main server. Data was transmitted to the RUMS computer from a variety of locations by either current sensors or contact closure sensors, through direct wiring to a connector box and the PC. Data management, displays, and alarm emails were provided by the Rums Server application software, utilizing National Instruments' LabVIEW. (See Fig. 81.) This was a joint project by the Microlab's computer staff, Tim Duncan and T. K. Chen, led by Todd Merport, in cooperation with Danny Pestal from the equipment engineering staff.

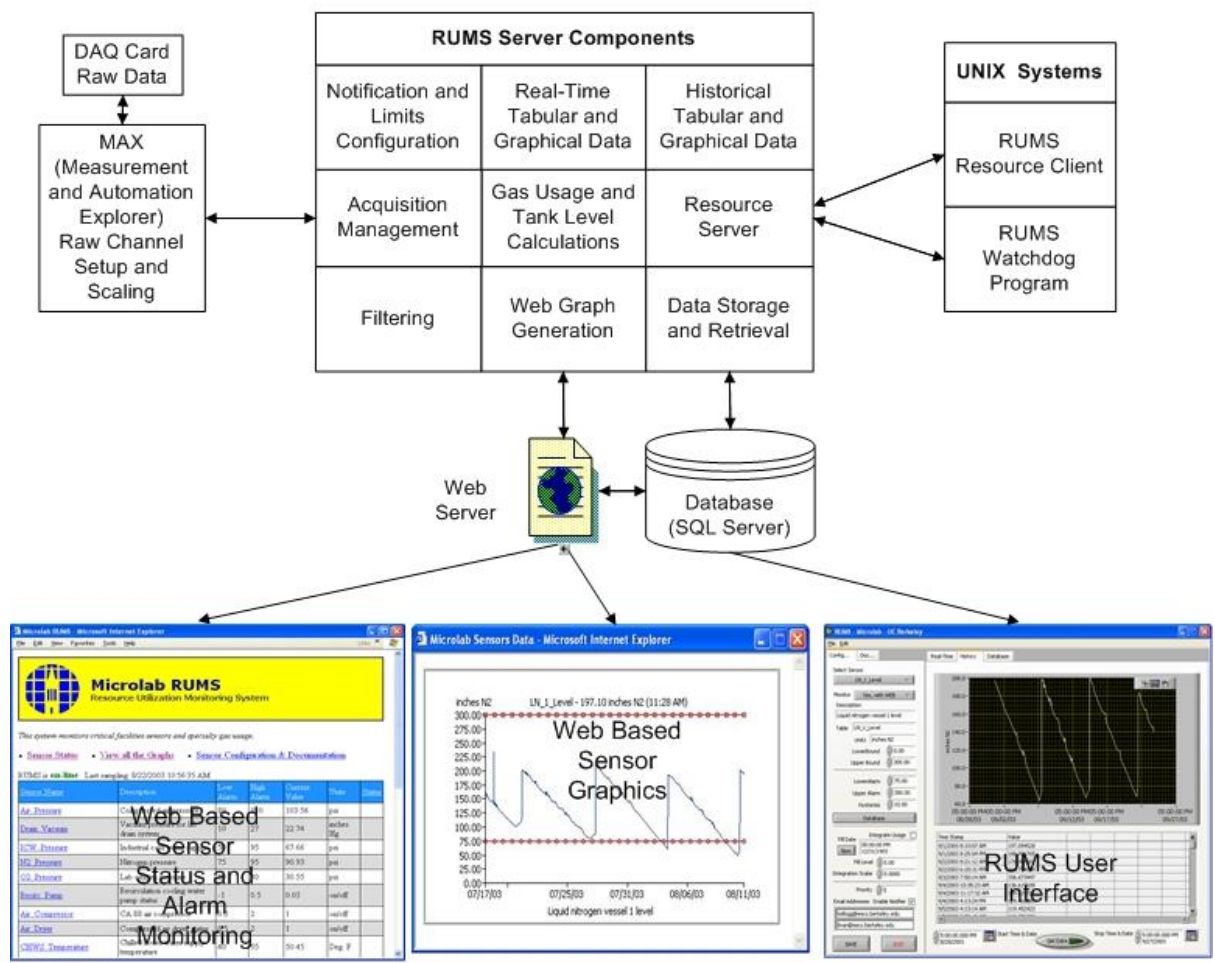
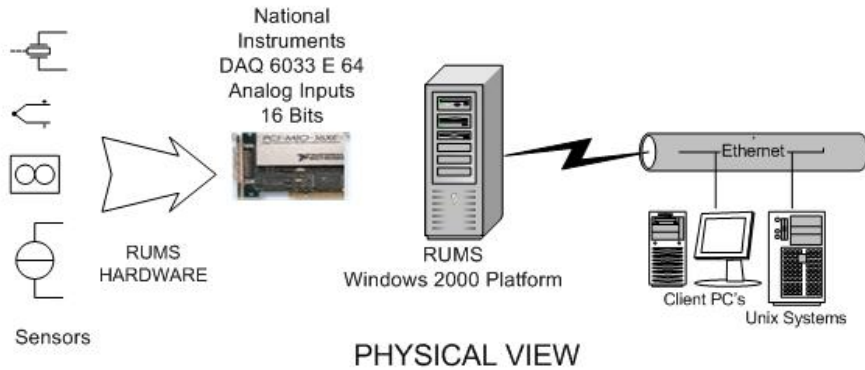

Fig. 81. Resource Utilization Monitoring System, RUMS (2003) [41].

Microlab Computer Systems Infrastructure

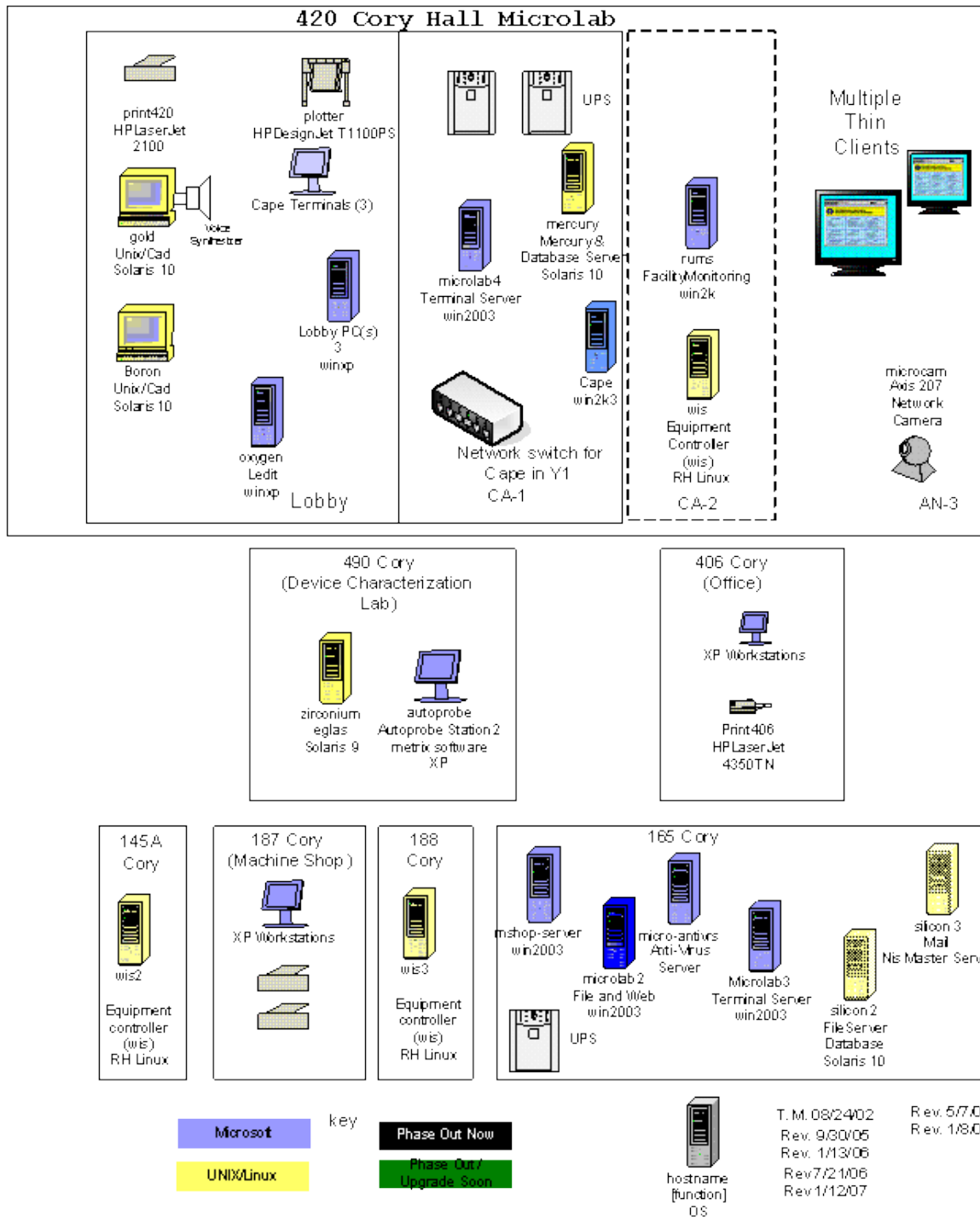

Fig. 82. Microlab computer infrastructure after the upgrades, in 2007.

Microlab Web Server Infrastructure

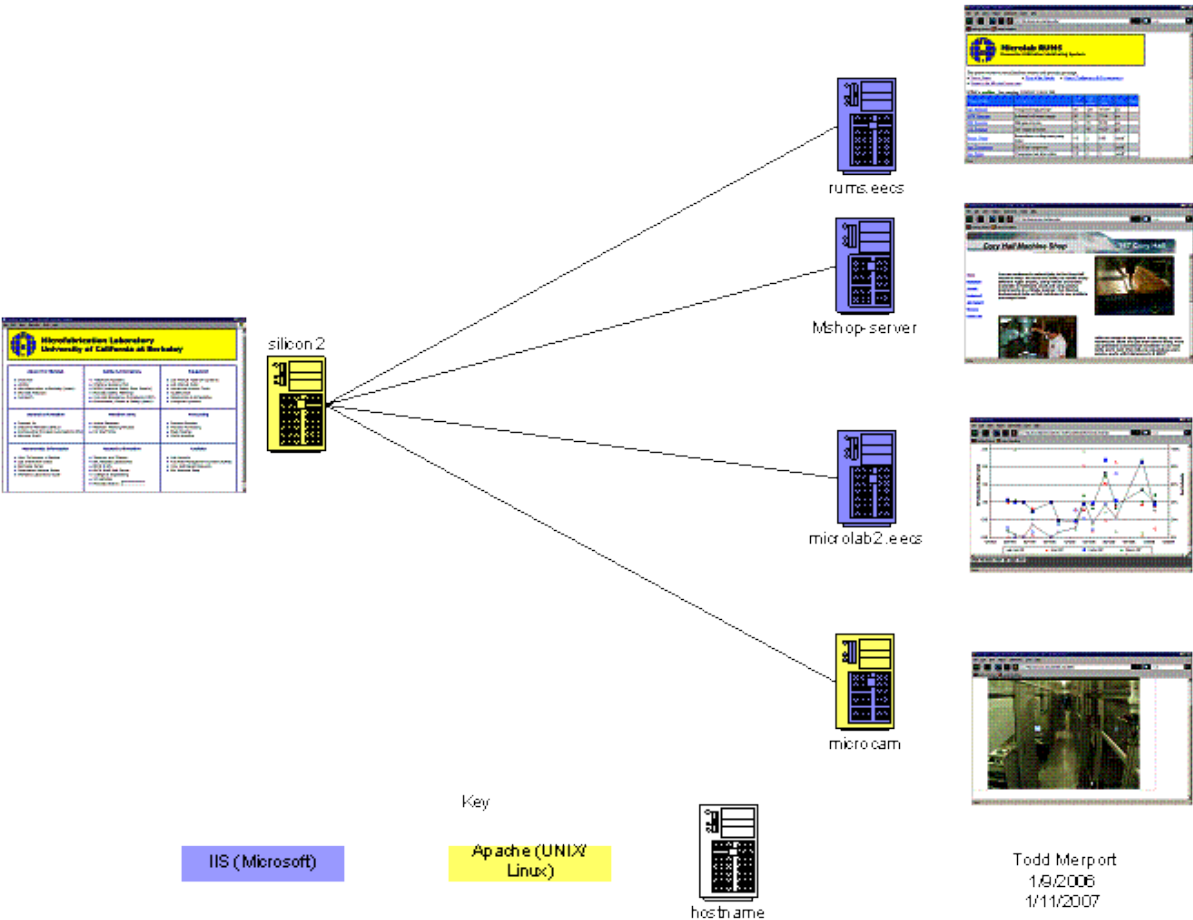

Fig. 83. Microlab web server infrastructure, 2007.

New Design – Mercury

The Microlab’s computer infrastructure after the upgrades is shown in Fig. 18 and 19, presented by Todd Merport. By the time the upgrade projects were completed, plans for a new engineering building, including a new lab, were approved. Construction Phase I (demolition) began in 2004 and management started to prepare for the eventual move. Just as in the case of the start-up of the Microlab, computer systems development paralleled the evolution of facilities and equipment plans. There was a major difference, however; the new system had the advantage of the old BCIMS behind it. With 25 years of experience in constant use, (two million activities captured,) many enhancements, upgrades, and fine tuning, BCIMS provided a solid foundation for the design of Mercury.

As there was no available good acronym, the new software was named by Todd Merport: Mercury (after the Roman god that served as a messenger to other gods and was himself a god of commerce, travel, and thievery). When beneficial occupancy of the Marvell NanoLab was granted in the middle of 2009, the computer system, hardware already bought, software installed and tested, was the first to go in. The NanoLab started operating on Mercury when the first tool, the e-beam writer was moved in, in October 2009.

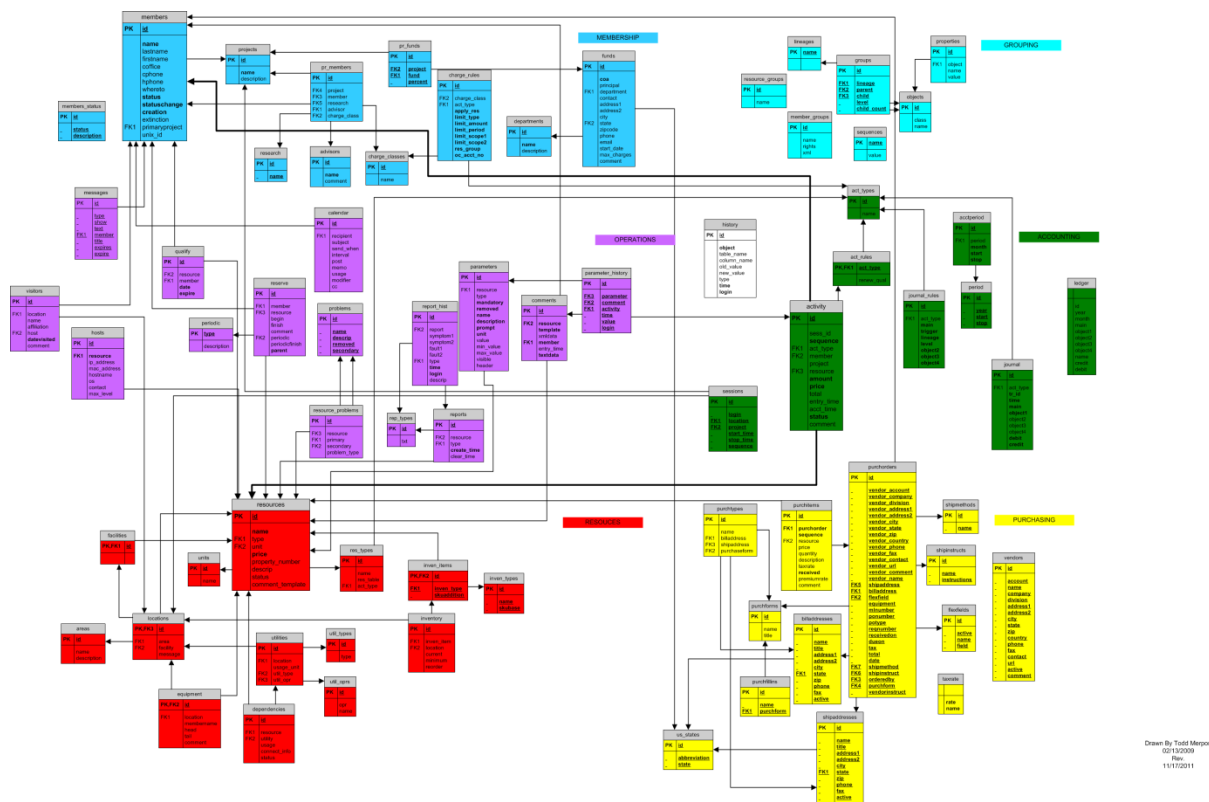

Fig. 84. Mercury database schematic layout (Todd Merport, 2009).

The Mercury project started out with a new **database** design. Todd Merport and Ferenc Varju did a terrific job of streamlining and creating a clear structure, shown in Fig. 84. Blocks of the same color indicate the following groups:

- Membership, with attributes of members ID, status, advisor, department, projects, funds, charge class, charge rules, research (top left)
- Grouping, with members-, resource-groups, objects, properties (upper right)
- Operations, with parameters (for resource used), problem reports, reports history, reserve, calendar, on-line tests, qualify, history (middle left)
- Accounting, with sessions, activity, acct. rules, types, period, journal, ledger
- Resources with name, type, equipment, utilities, location, dependencies, inventory items (lower left)
- Purchasing, with orders, items, types, forms, vendors (lower right)

A major difference between the old and new design was that Mercury creates accounting records by utilizing a double entry accounting system: lab activities are recorded and debited/credited to the appropriate accounts in real-time.

Todd Merport and Olek Proskurowski described the Mercury system as follows [40]:

“The components of Mercury are a relational database management system (Ingres), daemons, and clients, in a dual, three tier application. (See the Fig. 85.) The program which runs inside the laboratory is called MercuryClient. It connects to a session management daemon, Mercury Server. There is another client system that runs in a browser, MercuryWeb. Most of the logic or business rules for the system are implemented in the database as stored procedures. This helps insure data integrity and improves speed. It also minimizes duplication of procedures in the middle tier and clients.

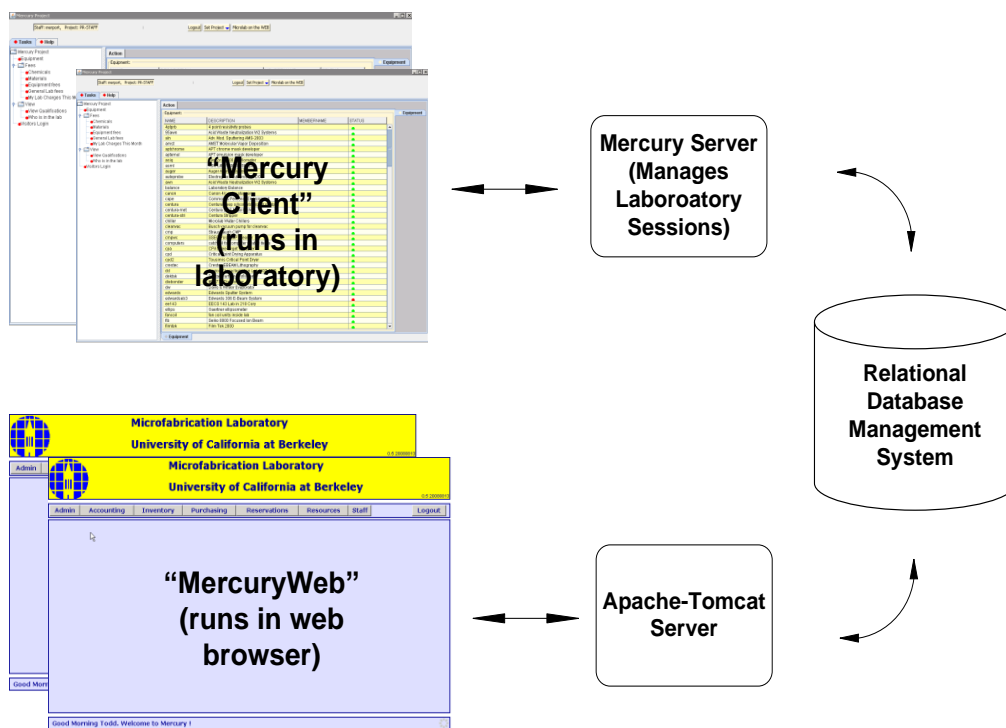

Fig. 85. Mercury structure, a dual three tier application system [40].

MercuryClient is a Java application that members use in the laboratory. When the application is run, a sign-in window appears. Members enter their login name, password, and select a project associated with their account. If members are qualified to use the lab, the full MercuryClient screen appears (lab charges commence). At this point they are connected to the Mercury database through Mercury Server and have access to equipment status, qualifications, materials, viewing who is in the lab, and more.

The main task for members, once logged in, will be to select an equipment row and enable the equipment. Several rules are checked at this point including presence, equipment and facility qualifications, and problem reports. MercuryClient maintains a continual session with the server

and holds session information such as location, lab time, and idle time. The graphical user interface, **GUI**, for MercuryClient was designed by Eniko Seen, and has the look and feel of CORAL. Semaphores indicate tool availability and activity options are available from a drop-down menu, also the lab manual for the tool. (See Fig. 86.)

MercuryWeb, designed by Olek Proskurowski, is a web application that provides lab members and staff access to the Mercury database system through any web browser. MercuryWeb is written in Java and uses SQL queries and stored procedures to access and update data in the Ingres RDBMS. MercuryWeb also allows creating various reports in PDF, Word, Excel, and PowerPoint formats. It includes the following major modules: Accounting, Inventory, Member Management, Online Tests, Facilities, Reservations, Calendar, and Tasks.

The Accounting module is used for day to day tasks as well as to create end of month financial statements and reports. The Inventory module helps to maintain the inventory of supplies and parts used in the lab. Member Management provides member and staff account setup and administration. Online Tests allow creating, taking, and grading tests online, completely replacing paper based tests. Facilities are used to define resources (equipment, utilities, and locations) and create associations between them. The Reservation modules allow lab members to reserve frequently used equipment.” (See Fig. 87.)

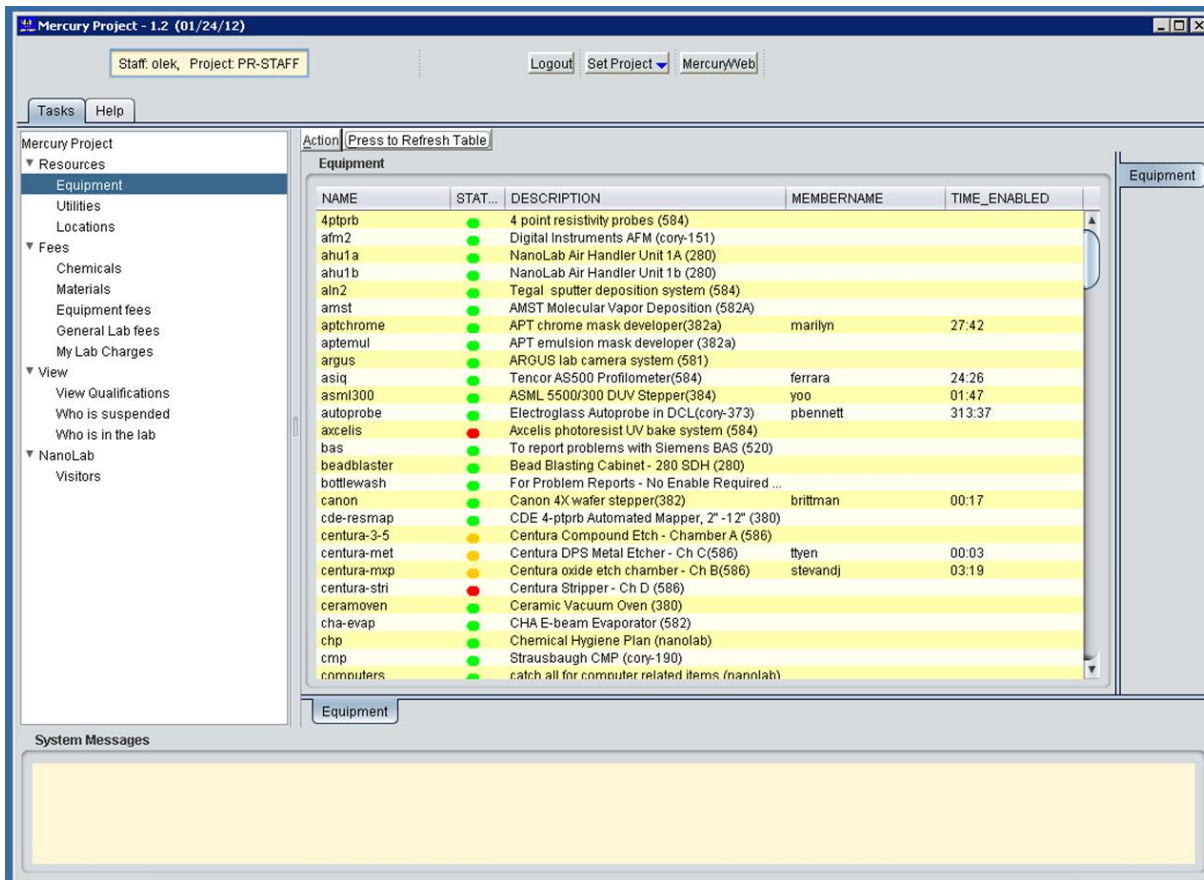

Fig. 86. Interface of MercuryClient (2009).

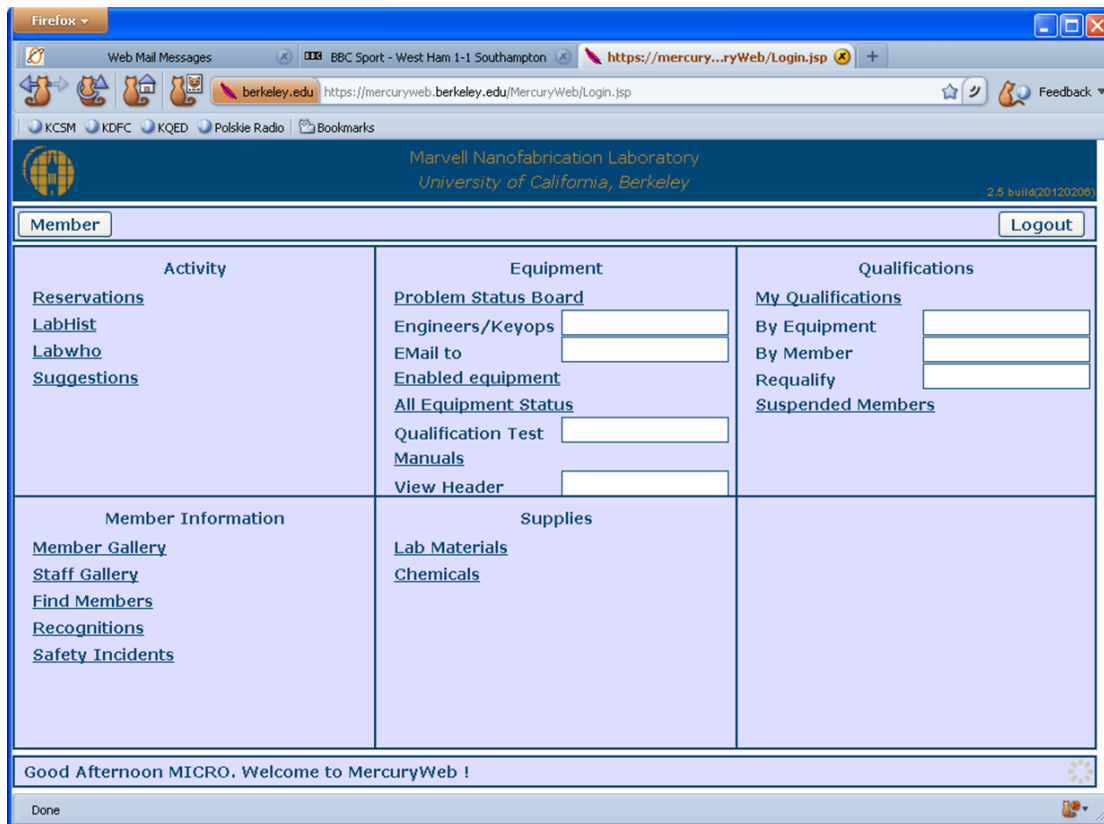

Fig. 87. Interface of MercuryWeb (Olek Proskurowski, 2009).

New Equipment Interlock System – Hydra

The equipment control system was also redesigned for the new lab. WIS needed to remain in place for the duration of the move and anyway, and it was time to upgrade. Todd Merport designed the module from off the shelf components, at 25% of the cost of the custom made WIS. (See Fig. 88.) It is based on the Agilent 349080A Multifunction Switch/Measure unit equipped with multiplexing high-density magnetic latching relays. The system is configured to send a pulse to an addressed channel which is connected to a Hydra interlock box. The 349080A has a serial, GPIB, and network interfaces allowing for very flexible operation. Todd Merport wrote the software interface between Mercury and Hydra (which he also named). The system was deployed in the new lab along with the equipment move.

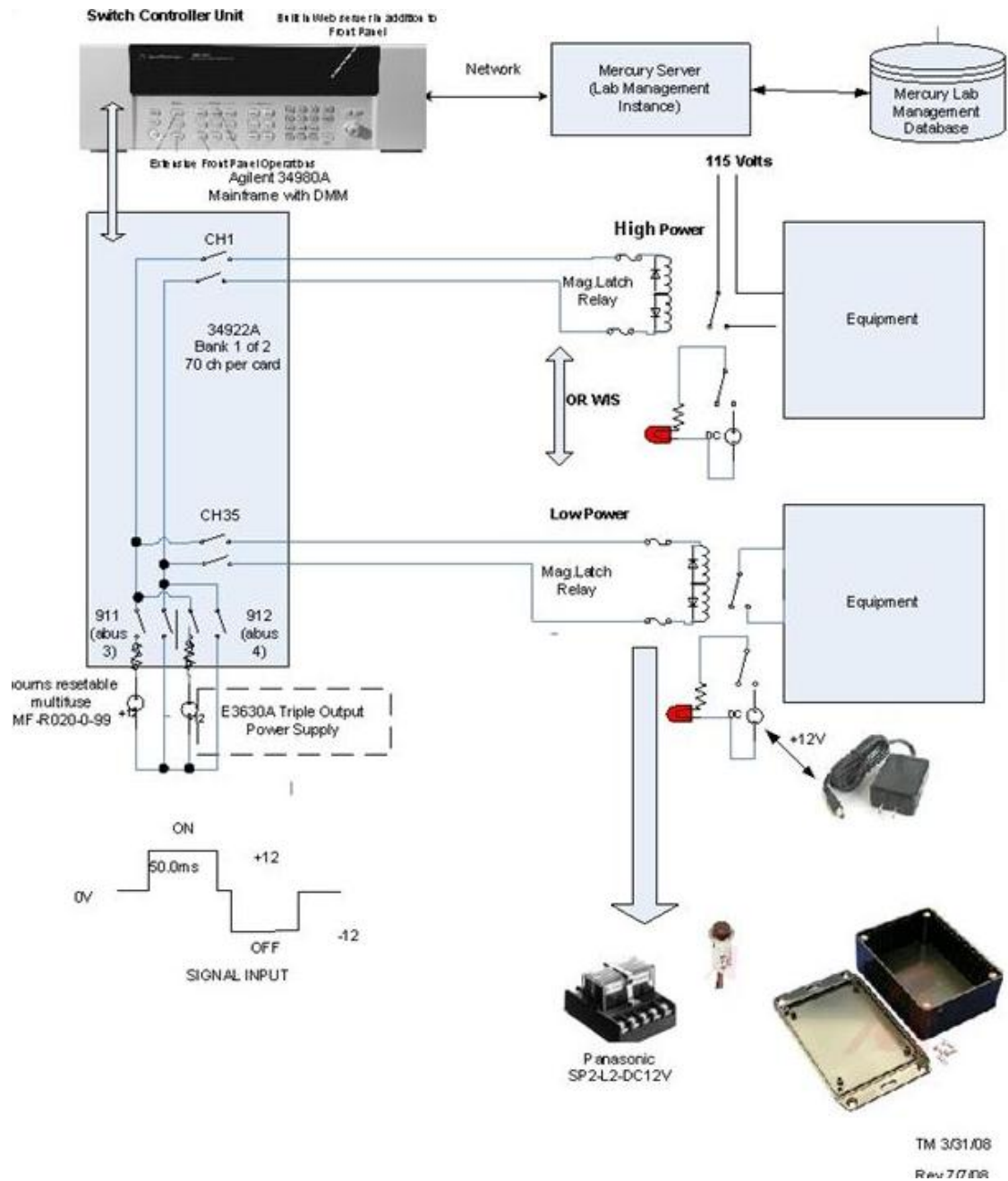

Fig. 88. Hydra equipment control system (Todd Merport, 2008).

Parallel Operations and Synchronization

The transfer of the Microlab into the new Marvell NanoLab was a gradual process, without shut down. It took close to two years to complete it (2009-2010), during which both BCIMS and Mercury were running parallel and maintained at the usual high level of uptime. Depending on which lab the tools were located in, lab members split their time between the two and followed login procedures accordingly: BCIMS/WAND in the Microlab and Mercury in the NanoLab.

Interestingly, the split operation did not agitate the users; they complained only when the specific equipment they were interested in, was down for the move.

Administration of two labs as a single operation was made possible by the outstanding efforts of the computer staff. They rose to the challenge of combining data from two different systems, which they solved by assigning the Mercury database as the primary, to which the secondary, BCIMS/WAND, data was uploaded daily. Olek Proskurowski wrote a clever synchronization program, which was thoroughly tested and checked by the administrative staff, before it went online, starting January 2010. (Fig. 89.) The accounting reports produced looked like a single operation, making the transfer completely transparent to campus administration.

Summary of the Microlab's Computer System Development

30 years is practically an eternity in the life of computer systems. The only way Microlab operations could continue to rely on its information and management system was by continuously developing and upgrading, following closely as computer technology evolved. These were the mile stones:

➤ **CIM Project Start: 1982**

Originally a research project for a paperless Microlab
A set of software tools, approx. 200 distinct programs in C, C++
Server: VAX/DEC (Merlin)
Database: Ingres
Interface: ASCII, menu-driven WAND and STAFF (Fig. 60.)
Terminal server: Pluto
Modules for:

- equipment access control (Taurus, equipcntl)
- reservations (reserve)
- recharge accounting (acct)
- purchasing and inventory control (purchase, inven)
- equipment and process documentation (FAULTS, DOC)
- facilities management (BLIMP)
-

➤ **Upgrades: starting 1990**

Microlab "Production" computers separated from research
Server: SUN workstation (Argon)
Equipment communications expanded
Equipment control extended to satellite labs
First website: 1994

➤ **Sic-Inch Upgrade Project: 1998-2004**

Integration of PC/Windows workstations into the Sun/Unix environment

Server: Solaris platform (Silicon)

Database: Ingres II

New terminal server: CAPE

New modules:

- equipment access control (WIS)
- Microlab Gas Database
- facilities management (RUMS)
- website redesign and enhancements

➤ **New system, Mercury, for the Marvell NanoLab: 2003-2009**

Servers: mixed platforms, Solaris 10, Linux, Microsoft

Database: Ingres – major redesign

Software: dual, three tier application

- Lab operations: MercuryClient with web based GUI, MercuryServer managing lab sessions
- Access to database: MercuryWeb (Java) with Apache-Tomcat server, new application modules
- new NanoLab website: <http://nanolab.berkeley.edu>
- new equipment controller (Hydra)

➤ **Parallel operation of two systems and synchronization**

- Microlab closed, WIS equipment controller shut down
- RUMS-Cory: Cory Hall utilities monitoring
- RUMS-Nano: NanoLab utilities monitoring
- WAND/STAFF and Microlab website in archive mode

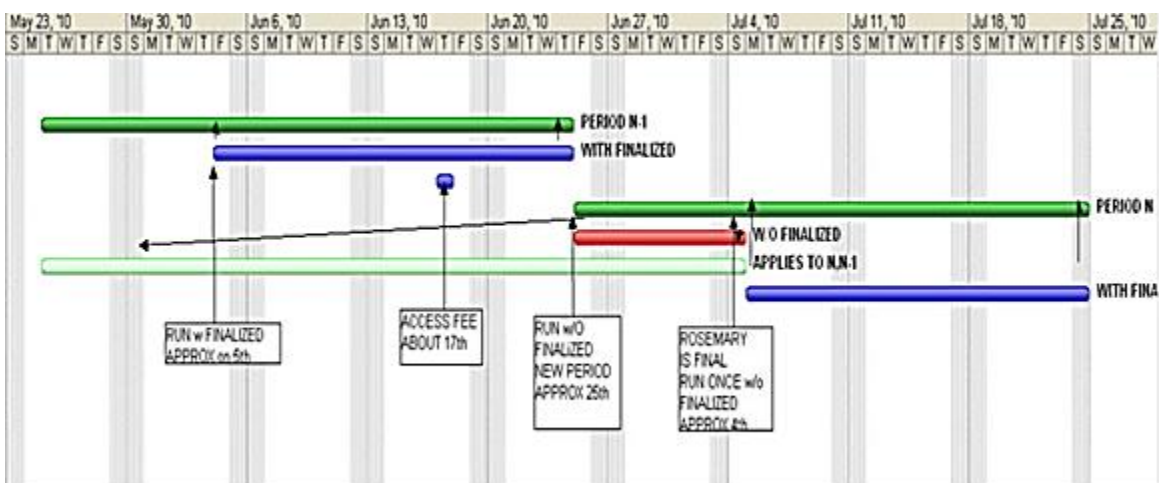

Fig. 89. NanoLab Cory Hall Infrastructure Synchronization (T. Merport, 2010).

VIII. Planning, Development, and Communications

Laboratory Development

The Microlab's history consisted of one continuous development. Taking a closer look, several distinct periods of high activity can be discerned. These were:

- **Start-up: 1983-1986**
- **Expansion into Satellite Labs: 1993-2004**
- **Six-Inch Upgrade: 1998-2004**
- **New Lab Development: 2004-2009**

Start-up: 1983-1986

When the Microlab opened officially in March 1983 equipment placement was in progress, but not nearly completed. During Summer and Fall the lab was made ready for the first CMOS class, 290-N/290-O, to commence with Professors Oldham and Neureuther. The Fall semester was spent on design and simulation [7], and processing began in the Spring. Testing was completed in the Summer of 1984 [8].

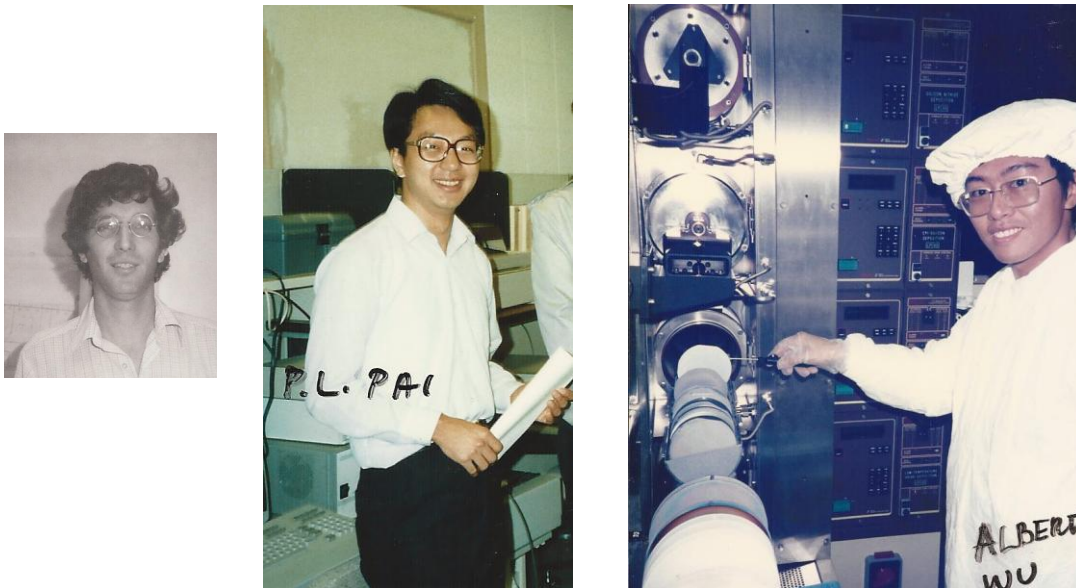

Fig. 90. Three members of the first class in CMOS processing (1983-1984).
L-R: Dr. Yoshi Shacham, Pei-Lin Pai, and Albert Wu.

The first run was an ambitious $1.25\mu\text{m}$ (gate length), 8 photo mask, 4 ion implantation, polysilicon gate, aluminum metal process. It produced working devices on 4" Si wafers. As the lab had just opened, and every tool needed characterization, graduate students worked way over and beyond expectations to be able to complete the run by the end of the semester. They were:

Ih-Chin Chen, Brian Childers, Michael Chin, Thomas Chuh, Carl Galewski, Juan Goicolea, Raif Hijab, In-Shek Hsu, Jack Lee, Steve Lester, Bob Monteverde, Pei-Lin Pai, Joe Pierret, Rick Spickelmier, Kai-Yap Toh, Jeremy Tzeng, and post-doctoral fellows Francois Dupuis and Yoshi Shacham. Fig. 90 shows three members of the first class.

The start-up phase continued into 1985-1986, when K. Voros was hired as a process engineer to develop and stabilize processes, to establish, and to document process modules, for standard NMOS and CMOS [10]. Also, she trained the process staff in what was needed for a well-controlled operation.

Expansion into Satellite Labs: 1993-2004

In 1993, through a 5-year National Science Foundation grant, the Integrated Materials Laboratory (IML) was formed to fabricate low-dimensional materials. It was established jointly by three departments, Materials Science and Engineering, Physics, and EECS. Three major pieces of equipment formed the core of the IML: an ultrahigh vacuum (UHV) connected system of molecular-beam epitaxial (MBE) growth, metal deposition, and characterization system; a Jeol scanning electron microscope (SEM) with Nability software for e-beam writing, and a high resolution X-ray diffractometer. UCB matching enabled renovation of laboratory space on the first floor of Cory Hall and provided one FTE staff support. Alex Para, EECS Building Engineer, was the project manager for the renovation. It was stipulated that the operational structure of the IML will be similar to that of the Microlab and that it would be a self-supporting recharge operation by the end of the 5-year grant.

Dr. Nate Newman of MSE developed the research plans for the IML, procured the equipment and started up processes; the operations were managed through the Microlab. Because there was a large overlap in membership of the two labs, the same safety and laboratory controls and procedures applied in both. Regardless of the location of the equipment (Cory Hall, HMMB, or LeConte Hall during the renovation of the HMMB,) computer control and the WAND interface made it look to the users like one operation. The IML was an independent recharge unit, which was managed by Microlab administration for 10 years.



IML Managers (L-R): Nate Newman (1993-1996), Prashant Patak (1996-1998), and Robert Prohaska (1998-2004)

After the original 5-year grant expired the IML began to struggle financially. With changes in research agendas of the participating PIs, use of the equipment fell to levels where maintenance for general use was no longer justifiable. Also, MBE systems are sensitive and difficult to operate; thus, they do not easily lend themselves to research applications by multiple users. In 2004 Microlab management submitted a proposal to the three department chairs, to consolidate the IML and the Microlab, which was accepted.

The satellite labs concept started with the IML and continued with the 6” Upgrade project. Some of the tools received as matching fund donations were too large to locate in the Microlab; thus, these had to be placed in satellite labs on the first floor of Cory Hall. This expansion is described in more detail in the Facilities – Satellite Labs section of this report.

Six-Inch Upgrade: 1998-2004

The next development phase took several years of planning and six years to complete, the upgrading of the silicon wafer processing tool set so it could handle 6” diameter wafers. Research pressures were mounting for several years to move closer to industry standards but no external funds were dedicated to this effort. See *VI. Finances*. The Six-Inch Upgrade section describes the method by which Microlab management was able to execute this long-term project – by boot strapping. A detailed report, including finances and time line, can be seen here: <http://microlab.berkeley.edu/text/6inchup/finalrpt.html>. 6” Upgrade activities are illustrated in Fig. 91-96.



Fig. 91. Arrival of the first tool dedicated to 6” wafers. Bob Connelly, equipment technician assisting with delivery, 2000.



Fig. 92. ASML engineer with Sia Parsa, Microlab Process Engr. Manager and the first wafer printed on the new ASML.



Fig. 93. Henry Heidbreder of Tystar Corp. assisting with upgrading the furnaces.

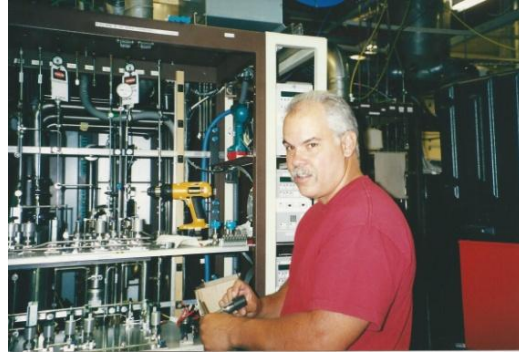

Fig. 94. Mike Linan, Microlab staff engineer working on the gas delivery system of the LPVCD tubes.



Fig. 95. More work needed on temperature control.

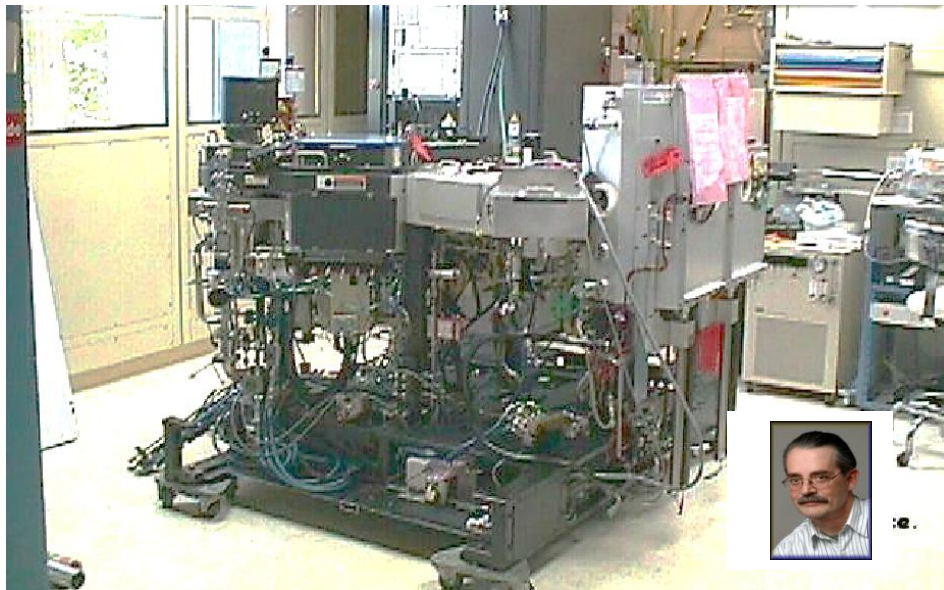

Fig. 96. The last large tool to be placed, in an undersized space, GL1 in the Microlab, the Centura (2004). This photo shows the tool stripped down to the smallest possible part, without the 6-pump stack, gas delivery system and power control module. The walls of GL1 had to be removed for siting.

Inset: Microlab engineer, Evan Stateler, who made it happen.

New Lab Development: 2004-2009

In 1998, Prof. Spanos, Faculty Director of the Microlab, sent an email to lab member PIs, with the ambitious title: *Microlab 2002 - think about it!* In it he asked his colleagues to provide input on how they see their own research developing in the next ten years and what kind of experimental infrastructure they would need to support it. Based on the responses, all pointing toward feature size reduction, and looking at space possibilities on Campus, including a joint lab with LBNL, Microlab management submitted a request for new space to Dean Newton of the College of Engineering. This request coincided with COE's plans to submit a proposal to the *Governor Gray Davis Institutes for Science and Innovation* initiative of the State of California. The Berkeley proposal, jointly with Davis, Merced, and Santa Cruz, was funded and the Center for Information Technology Research in the Interest of Society (CITRIS) was established in 2001, with Berkeley as headquarters.

Planning for a new building, including a NanoLab, began immediately. Because of the limited space available on campus, one option would have built the lab in a separate building off campus, at the Richmond Field Station. This idea was unacceptable for lab member PIs and Prof. Spanos mounted an intensive lobbying effort to have it taken off the table. It was.

Microlab management was deeply involved with the design of the new lab. After Jim Bustillo, Technology Manager, resigned in 2000, Dr. A. W. Flounders came on board in 2001. Bill was a Microlab alumnus (PhD in Chemical Engineering, 1992) and was able to continue with the plans without delay. He was successful in convincing the general contractor for the building to hire Abbie Gregg, Inc., a lab design firm with whom the Microlab already was working on capacity and operational modeling. Details of the new lab are described in the *V. Operations*, Facilities section of this report, pages 32-35. Financial details are on page 84.

The move of the Microlab into its new location, the Marvell NanoLab was executed entirely by in-house staff, without shutting down the Microlab. Management developed a fit-up and migration plan which was put into effect as soon as partial beneficial occupancy was given, in June 2009. (See Fig. 97.) This plan was detailed down to individual tools, listing space and utility requirements, and module move schedules.

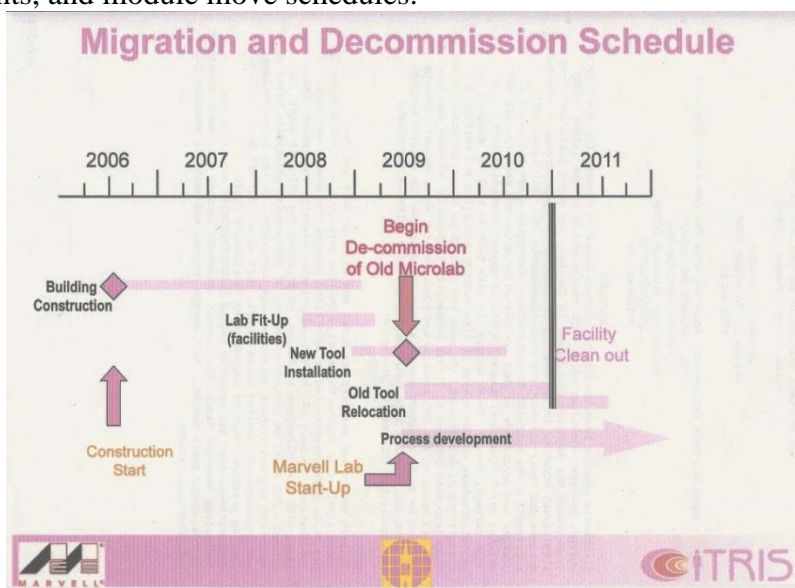

Fig. 97. Microlab migration schedule (W. Flounders, 2009).

Partial beneficial occupancy for the Marvell Nanofabrication Laboratory meant that utilities, such as power, cooling water, exhaust ducting, specialty gases distribution to planned machine locations, could start. This turned out to be a huge job, although planned for. Besides value engineering demands, the motivating factor in managing fit up with Microlab and Machine Shop staff, was the flexibility needed in making last minute changes in tool locations. In spite of the enormous additional work load on staff, this was a good decision because changes were needed to be made from the original tool layout almost from the beginning. Since the Microlab continued to operate 24/7, there was no time pressure and tool siting could be optimized.

Additionally, 14 new tools, with high utilities demands and complex installation needs – not specified early in the design process – had to be accommodated. The biggest hit from value engineering was the elimination from the construction plans of the 12 sinks and their installation. This was a hard decision, because the other option would have been to give up outfitting of the gas vaults and delivery systems, to meet the latest code requirements.

By the end of 2009 the Marvell NanoLab, with two tools, the Crestec e-beam writer and the Leo SEM, was open for operation, under the management of Bill Flounders. A new NanoLab orientation program, in addition to the standard Microlab orientation, was instituted for lab members who were qualified on these two tools. As fit up progressed, other equipment were slowly moved in; thus, beginning in December 2009 two labs were running. The doors of the Microlab in Cory Hall closed in December 2010, 28 years after they were opened and 48 years after the first integrated circuit processing lab started in Cory Hall.

Membership Development

As discussed in the *VI. Finances* section, the viability of the Microlab depended on its members from the beginning. Thus, management placed a great emphasis on increasing the number of users, by advertising the capabilities of microfabrication technology and the availability of the EECS facility to all researchers on Campus, in the UC System, and to other academic institutions.

Principal investigators were informed by personal visits, letters, informational booklets, and seminars, at every available opportunity, to increase the visibility of the Microlab. The excerpt below from the 1987 booklet describes the attractive features of the lab [14].

The Microlab is a complete facility in which semiconductor devices and circuits are fabricated, beginning with layout, all the way through testing. The student study area is equipped with graphics terminals and a workstation for those who do not have layout capability in their own department. All lab users receive an account on the Microlab's computer, Argon, which is connected to the department and campus Ethernet. Equipment is shared by all users, except for those items that, by necessity, are dedicated to specific processes in three major categories – silicon, III-V compounds, and superconductors. There are about 150 registered users; up to 30 usually work in the lab at any given time.

The facility is accessible with a key card 24 hours a day, 365 days a year, the only rule being that no one can work alone. Anyone wishing to work in the lab must take a one-day orientation course, presented by Microlab staff, which focuses on laboratory safety procedures. They must then pass a safety test before being granted admission to the lab. Students learn to operate equipment and to run processes from their fellow students. They become qualified users on a given machine after demonstrating to a “superuser” that they are sufficiently familiar with the operation of the instrument. Usually, two superusers are designated to a machine. They are senior graduate students whose research depends on the well-being of that equipment. The qualified and superuser lists are updated immediately, and the new student is allowed to operate the machine independently.

We believe in allowing students as much freedom as possible, even at the expense of equipment breakdowns. They are encouraged to try out new ideas and are welcome to draw upon the experience of the staff, both in equipment and process technology.

In 1989 management established a set of guide-lines to follow [20]:

1. The lab maintains, with staff, a baseline 2 um CMOS process to calibrate and exercise equipment and provides standard process modules and foundry service for device and IC people.
2. The philosophy of the lab management is to accommodate the needs of all users, as far as possible without detriment to the work of others. This especially applies to sensor research, which involves both standard MOS and esoteric processes.
3. The lab continues to provide strong support for compound semiconductor research, by maintaining dedicated equipment and addressing special needs.
4. The lab maintains a dedicated room and equipment for superconductor research. Staff cooperates with their research engineer to provide optimum support.
5. The lab maintains a dedicated room and equipment for deep UV photolithography research. Staff cooperates with their research engineers to provide optimum support.
6. Management strongly encourages and helps interested researchers from other departments and from other UC campuses to use our facility.
7. In general, the facility is used to carry out non-standard processes, which are not available commercially.

Along with academic lab members, industrial membership, (first those who were Microlab alumni,) slowly increased. More on this in the **Industrial Members (BMLA)** section of *VI. Finances*. Once in the lab, there was no distinction among members, regardless of where they came from.

Membership development activity, intensive during the first ten years of the Microlab, paid off in increased numbers, resulting in financial stability. During the 28-year existence of the Microlab it served a total number of **3801 lab members**. Fig. 98 shows membership numbers from 1989 to 2010. Fig. 99 depicts distribution of lab membership by department, in Fiscal Year 2009/2010.

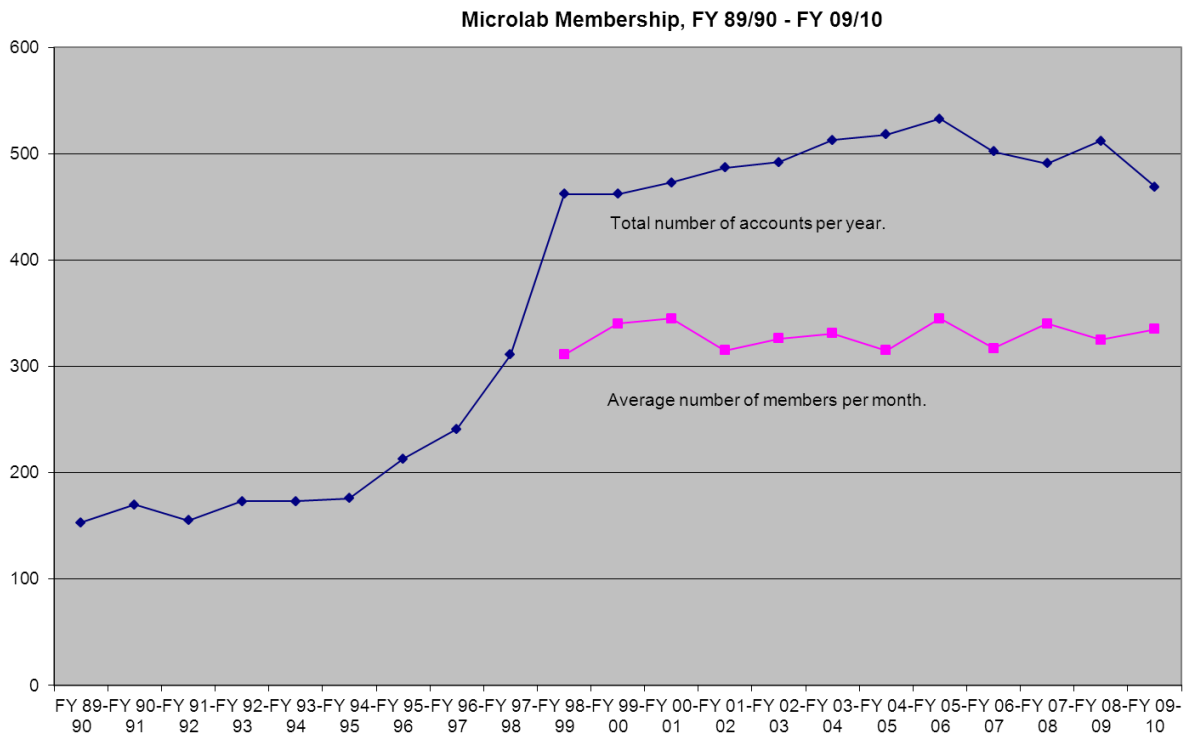

Fig. 98. Microlab membership, 1989-2010 (Rosemary Spivey).

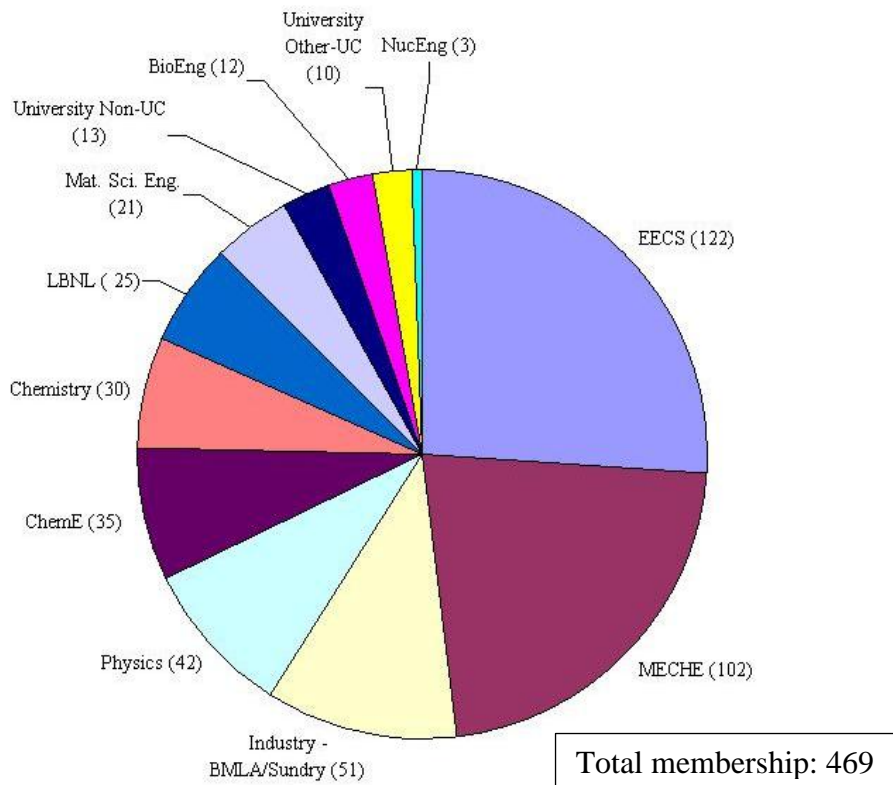



Fig. 99. Microlab membership by department in FY 2009/2010 (Rosemary Spivey).

User Training – Lab Orientation

Lab member orientation seminars were given once a month, every month (except December) throughout the life time of the Microlab. This was open to anyone who indicated an interest –and on occasion even professors attended. The agenda for the day is shown in Fig. 100.



**Microfabrication Laboratory
Orientation Schedule
March 19, 2009**

The Orientation Seminar is held in the Hogan Room (400 Cory). The schedule for the day is as follows:

8:00	8:50	Introduction	Katalin Voros, Operations Manager
8:50	9:30	The Microlab Computer	Madeleine Leullier, Computer Res. Specialist
9:30	10:10	Safety	Bob Hamilton, Facilities Manager
10:10	10:20	Administration	Susan Kellogg-Smith, Purchasing Manager
10:20	10:30	Coffee Break	
10:30	11:30	Processing	Sia Parsa, Process Engineering Manager
11:30	12:00	Lab Etiquette	Marilyn Kushner, Jr. Development Engineer
12:00	1:00	Lunch Break	
1:00	2:00	Lab Tour	Marilyn Kushner, Jr. Development Engineer
2:00	3:00	Lab Tour	Jimmy Chang, Sr. Development Engineer

Fig. 100. Lab orientation seminar schedule.

During the lab orientation seminar, prospective members were given safety material to study and were required to take the orientation safety test. (A shorter version of this was the yearly quiz, mandated by EH&S, to ensure continued membership.) The lab orientation seminar, and passing the safety test, allowed the new member to open an account, for which a valid charge number, signed by the PI, was needed. She/he was allowed to enter the lab, use the computer and be trained on the tools needed for his research.

A tradition which started in the “old lab” continued to flourish in the Microlab: students trained one another in the use of equipment. After a new user demonstrated to the “Superuser” that he had sufficient skills to operate a tool, his login name was added to the qualified users list for that tool. This meant that the student could enable the equipment and could work independently. Qualifications were required for each tool separately, even for those similar in operation, like sinks. As membership increased precipitously during the mid-1990’s (and passed 200 in 1996,) written equipment tests were introduced for the more complex tools, to insure proper training.

Early on, as operations stabilized and process staff was in place, graduate student lab members were recruited to help with process module development, especially those which involved their own projects. This system worked well and fostered the feeling of ownership in the lab. Students

trained one another in tool operations and acted as “Superusers”, who could sign off on qualifications.

New lab members were given these basic rules to observe:

- Microlab – open for work 24 hours a day, all through the year, i.e. 24/7
- **For safety reasons, no one may work alone in the lab at any time.**
– **There must be at least two people inside when working off hours.**
- Learning – students learn from each other and, in turn, teach others.
- Information – Microlab website, <http://microlab.berkeley.edu>
- Questions/advice/help – e-mail machine_name@silicon.eecs.berkeley.edu
- Updates and information – will receive by email.
- Equipment operation – test and qualify on each equipment needed.
- Processing – use standard modules or develop own.
- Safety quiz – yearly refresher
- Clean-up – do your own
- Visitors – only by permission
- Credits – “Devices fabricated in the UC Berkeley Microlab”.

Controls

Managing a multi-user laboratory required a certain amount of discipline. While students were given wide latitude in experimentation and were rarely reproached for making honest mistakes, not observing safety rules was considered a major infraction. These resulted in suspension from entering the lab for three days to a week, or longer, depending on severity. The student’s PI was notified in each case.

Cheating, such as using another member’s account to gain access to a tool, drew the same response as above from management.

Not reporting a problem and then the student complaining to his PI that the machine was not working and he could not get his work done, drew the response from the lab manager shown in Fig. 101.

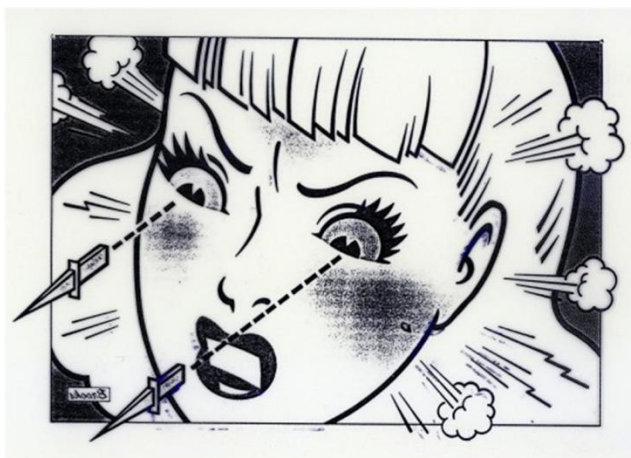

Fig. 101. Lab member’s view of Microlab manager.

If equipment problem reports indicated that a student's skill were not sufficient in operating a tool, he was requested to re-qualify and was not allowed to use it until he did so. Other lab members often complained about such cases and requested that written tests be added to the qualification procedures of complex tools. Also, staff gave group training sessions on a few sensitive tools, such as the SEM and e-beam writer.

Lab Members' Meetings

Management published (email) a Quarterly Newsletter in 1985, to inform lab members and their PIs of the status of the Microlab and of upcoming events. After that, communications with lab members were through email and through meetings with individual research groups. Regular monthly lab members meeting were started in 1990, providing a forum for concerns and suggestions. The frequency of these meetings decreased slowly, as interest in participation waned. A suggestion box was provided as another outlet in the lab for submitting ideas and complaints. Fig.102 shows one of the livelier lab members meetings, in 1991. In 1998 the meetings were renamed Lab Member and Safety Committee meetings and continued as such until a lab closed.



Fig. 102. Lab members meeting in 1991. Photo on the left: standing (L-R) Clark Nguyen and Carl Galewski; sitting Dave Monk (blue shirt), Rod Alley, Mike Judy (maroon shirt), Mark Noworolski, and Charles Fields (pink shirt). Photo on the right: Jim Bustillo and Mark Noworolski on left, on right (R-L) Bob Hamilton, Gary Fedder, Weijie Yun, Bob Ried, and Kirt Williams (only head showing).

Outreach – Summer Internship

In 1991, under the leadership of Professor Tsu-Jae King Liu, the Microlab started an outreach program, Summer Internship for High School Girls. The goal of the program was to expose young women to engineering and science activities, to environments and people not normally found in their science classes. Laurel Reitman, a high school physics teacher working in the Microlab as project manager during her sabbatical year, wrote a clear and concise description of what the internship entailed, which was posted on the Microlab's website under Outreach. <http://microlab.berkeley.edu/text/Outreach.html>

The program targeted high school girls, 16 or over, who have completed chemistry or physics classes, and lived in commuting distance from UC Berkeley. Applicants were required to submit a resume, and a letter of recommendation from their science teacher. Two or three interns were selected each Summer, based on qualifications, and a personal interview. General communication skills were assessed as was the ability to work independently. They received a stipend of \$1000. Without any advertisement there was a sufficiently large applicant pool. The internship was supported by the UC Berkeley Microlab Industrial Affiliates' program membership fees.

The program was conducted during June-August each year, 4 days/week. At the end, interns were required to give a Power Point presentation of what they learned and received a certificate of completion. Interns and their projects are posted at <http://microlab.berkeley.edu/text/participants.html>.

Departmental Activities

EE143 Support

A small independent facility in 218 Cory Hall is an undergraduate teaching laboratory, where students build NMOS devices as part of EE 143. The course, which existed even before the Microlab was built, is given each semester with six lab sessions per week; thus, the lab must be in running condition at all times. To assure proper lab skills, TAs were recruited from among those graduate students who were Microlab members. Microlab staff supported this facility from the start, when Phil Guillory was assigned and trained to provide processing equipment maintenance and other service support. TAs reported equipment and supply problems for EE143 on the computer, just like any machine problem in the Microlab; those were then taken care of by Microlab staff. Supplies and gases were purchased through the Microlab and recharged to the Department. The Electronics Support Group of the department, under Ferenc Kovac's management, took care of maintaining the test equipment.

Fig. 103. EE 143 TAs, Jiang Tao and Charles Fields (in white caps), demonstrating microscope use to lab group (blue caps). Photos were taken by Marilyn Kushner, 1974 Fall semester.



In 1987 Microlab processing staff redesigned the EE143 chip to bring it closer to industrial processes. Robin Rudell did the layout for the poly-silicon gate, 2 μm NMOS process technology and K. Voros, with Professor Ko, wrote an extended characterization procedure. Each lab group went to the Microlab to deposit poly-silicon (for which there is no provision in the 218 Cory Hall undergraduate lab) and had a chance to see an advanced semiconductor facility in operation. The new process was successfully introduced in the Fall of 1987. The lab manual, *EECS 143 Processing and Design of Integrated Circuits Laboratory Project*, came out in August 1988, and is still being used, with minor modifications, today [15]. (Fig. 103-105.)



Fig. 104. Head TA Jack Judy working with a student at the test station.



Fig. 105. Processing at the sink in the undergraduate lab, 218 Cory Hall.

Competitive Semiconductor Manufacturing Program

One of the goals of the Competitive Semiconductor Manufacturing (CSM) research project was to conduct comparative studies of the best semiconductor manufacturing plants to identify world-class managerial, organizational, technical, and human resource practices. The program, led by Professors David Hodges of EECS and Robert Leachman of IEOR and supported by the Sloan Foundation, brought together faculty and students from the College of Engineering, Haas School of Business, and Department of Economics, addressing key aspects of semiconductor manufacturing. The Microlab's management was also invited to join. This was relevant research for the Microlab's future; thus, Prof. Spanos and K. Voros participated.

The CSM project lasted 10 years (1991-2001), and evaluated 30 semiconductor manufacturing companies (K. Voros visited 16 of them with the group). The following website contains the findings and reports which resulted from this research project: <http://microlab.berkeley.edu/csm/>.

Graduate Seminar

Members of the Microlab were regularly attending the weekly Solid State Technology and Devices Seminars, EE 298-12, originally sponsored by Professors Hu, Ko, Cheung, Neureuther, and Oldham. Speakers were invited from outside, from industry, academia, and research institutions. Also, this was one of the venues for doctoral candidates to present their research.

In 1994 Prof. Hu asked Microlab management to take over organizing the schedule. This worked smoothly and the Solid State seminars were always well attended. The number of sponsoring faculty increased as new faculty arrived; sponsors were asked to invite and host two or three speakers, while Microlab staff handled follow-ups and postings, by email and website, <http://microlab.berkeley.edu/text/298-12.seminar>. Fig. 106 shows one of the more than 540 speakers the seminar hosted in 18 years.

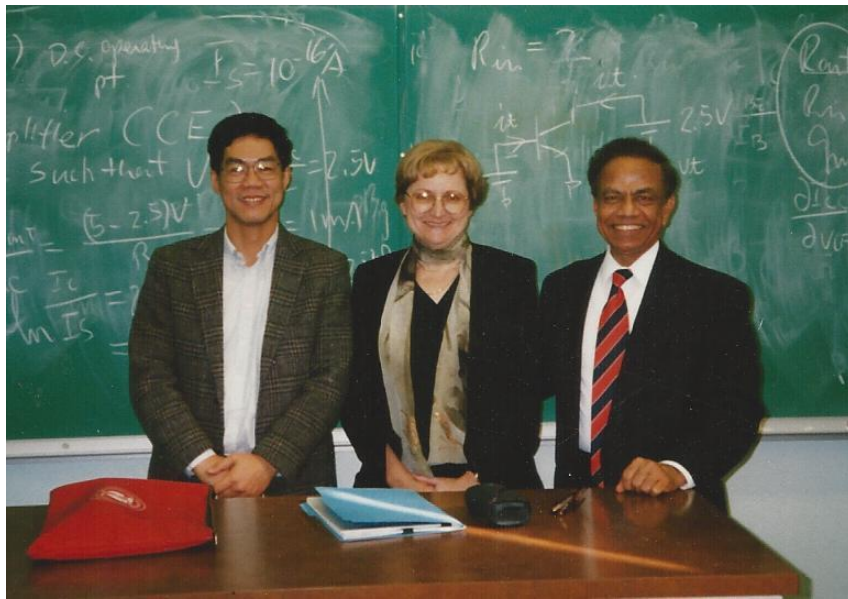

Fig. 106. 298-12 seminar speaker, Prof. Arjun Saxena of Rensselaer Polytechnic Institute, with Prof. Cheung, and K. Voros (Fall 1996).

Staff Activities

Starting with 14 FTEs in 1987, the staff of the Microlab grew to 25 by 1994, and to 30 by 2007, including associated researchers. Thus, the group was the largest, somewhat independent, self-contained employee unit within EECS/ERL, located on the 4th floor of Cory Hall. This meant that Microlab staff was visible on departmental staff committees, such as the **Cory Hall Safety Committee**, which had three or four members from the Microlab every year until the lab moved. One of the activities of the Safety Committee is shown in Fig. 107 and 108. Another was to ensure compliance with the EH&S mandated Injury and Illness Prevention Plan (IIPP).



Fig. 107. Cory Hall emergency evacuation (1993).



Fig. 108. Microlab Manager, member of the Cory Hall Safety Comm.

Wil Zeilinger, when he became the Department Engineer in 1984, started monthly meetings for the **Technical Supervisors Group**, to disseminate important and relevant information for the various employee units within EECS/ERL. After he retired in 1991 the group decided to continue these meetings and elected K. Voros, Microlab Manager as chair. In the interest of safeguarding the local environment of the Microlab, Katalin continued in this volunteer position for 12 years, 1993-2005, called the meetings and sent out the minutes monthly. Coordination and awareness of events was especially important during the renovation and seismic upgrade of the Hearst Memorial Mining Building (HMMB), which had a severe impact on the working environment in Cory Hall (1998-2002). “Techsups” meetings were discontinued in 2006, after ERL became ERSO and part of the COE.

In 1996 EECS went through a major reorganization of the technical support staff and K. Voros was asked by Prof. Messerschmitt, Chair of EECS, to accept temporary management of two departmental recharge units: **Computer Services** (until 1999) and **Special Projects** (until 2000) – in addition to the Microlab and the Cory Hall Machine Shop (which she had been managing already since 1994). For this service to the Department, Microlab Faculty Director, Prof. Spanos, requested that the Department fund another position in the Microlab. Thus, a new – half-time position – Microlab Technology Manager was created. This enabled K. Voros to spend the necessary effort to improve the financial status of the additional units, train their administrative staff, and hand over Computer Services to the new IT director, Hua Pei Chen, hired by the Department three years later. After evaluation and analysis Katalin proposed dismantling Special Services, which came to pass in 2000.

In the wake of the extensive staff reorganization, by the previous chair, Prof. Randy Katz created a **Staff Advisory Board** in November 1996, to provide constructive communication between staff and EECS/ERL senior administration. Marilyn Kushner represented Microlab staff ably on this committee for two years. Two of her suggestions, a Spring Flower Show and a Fall Veggie Expo, were adopted and were successes. The flower show, renamed the Rose Show, became a Microlab tradition, after Staff Advisory Board activities ceased when a new department chair took over.

Public Relations

Public relations activities were an important part of the agenda for the Microlab the first ten years. Showcasing the new lab, conducting tours for campus and government dignitaries, for visitors from founding agencies; for new graduate admits, who were in the process of deciding which school to choose; for faculty and colleagues from other universities, to spread the news of the success of the UC Berkeley Microlab. The Microlab regularly participated in departmental and College of Engineering industrial liaison activities, open house events, and Cal Days.

Management was keenly aware of the importance of providing accurate and up-to-date information about the Microlab. These were presented in informational booklets, on slides, hallway displays, and later in video programs, and the Microlab's web portal, all of which were regularly updated and widely distributed. Fig. 109-112 show examples.

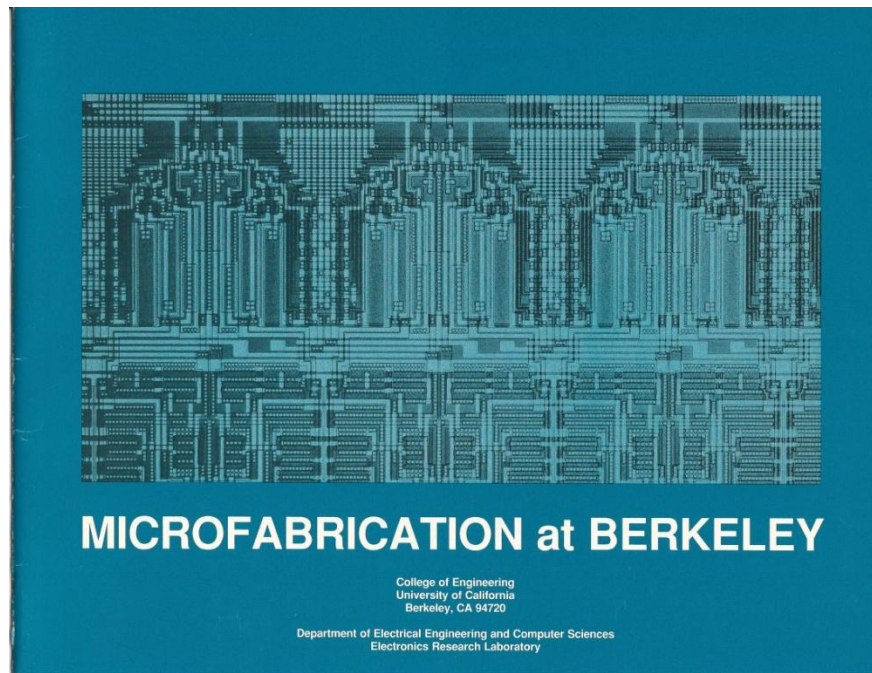

Fig. 109. Microlab informational booklet published in 1987.
Cover photo shows detail of pipelined A/D converter IC made in the Microlab.
Design: Lee-Chung Yiu (Prof. P. Gray).

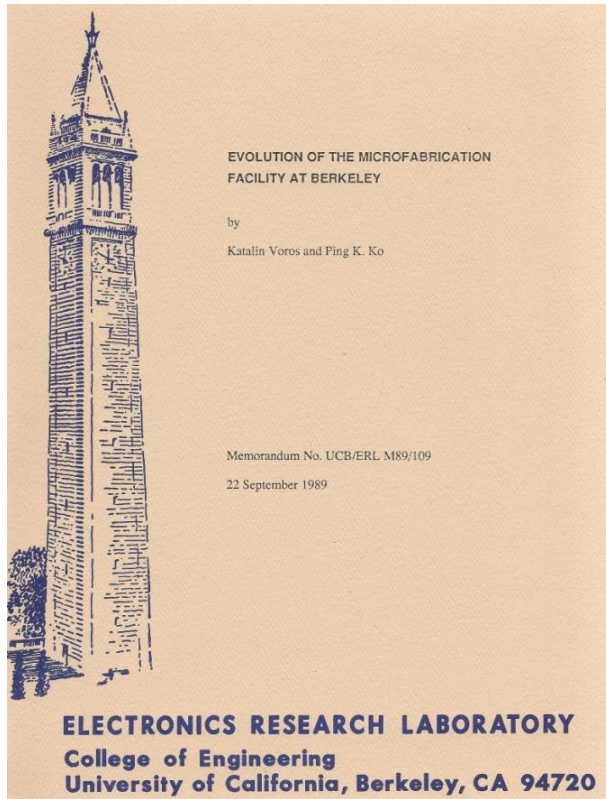

Fig. 110. Evolution of the Microfabrication Facility at Berkeley, ERL memorandum, 1989.

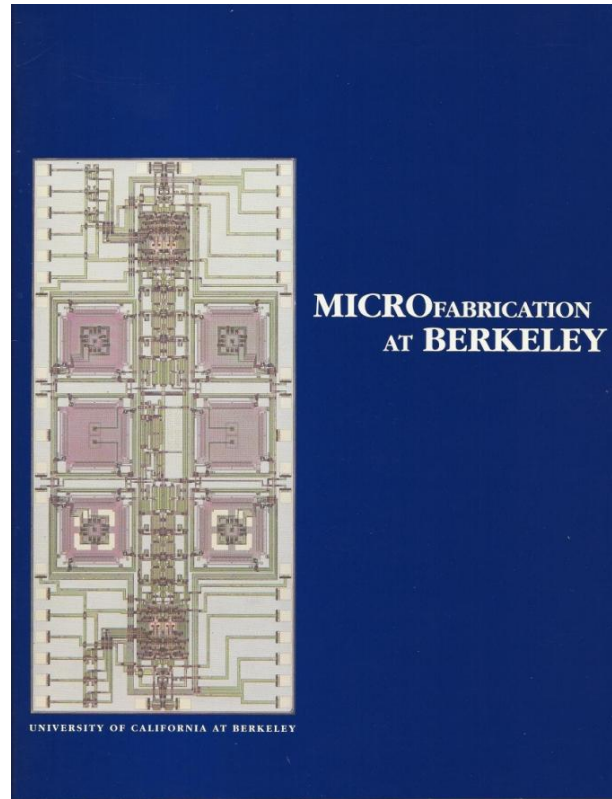

Fig. 111. Informational booklet, published for the Tenth Anniversary celebration of the Microlab, 1993.

The circuit shown on the cover of the 1993 booklet was designed and processed in the Microlab by Weijie Yun, (Professors R. Howe and P. Gray), a surface micro-machined, force-balanced accelerometer with on-chip modulator, using the MICS process.



Fig. 112. Hallway display on the second floor of Cory Hall, showing scenes from the Microlab (1988).

For the Microlab's Tenth Anniversary Celebration, historical photos of chips made in the old IC lab and the Microlab were added as displays on walls of the 4th floor hallway of Cory Hall. (See Fig. 113 and 114.)



Fig. 113. Profs. R. Muller and D. Hodges at the Tenth Anniversary reception (1993).



Fig. 114. Maria Perez (center), Microlab process engineer talking with her supervisor, Debra Hebert, at the reception.

To streamline public relations activities, the Microlab produced its first **video** in 1989, *Microfabrication Research at Berkeley*, using the recharge services of the Campus Office of Media Services (\$25K). Robin Rudell wrote the text, arranged for shooting, and assisted with post-production. This was an effort well spent. The video became an instant hit, but more

importantly, it reduced staff time spent on talking to visitors and reduced unnecessary traffic in the lab. Most people were glad to see the video outside and not have to gown up for a tour. The video was also used extensively as part of the orientation seminar.

In 1995 the video was remade by Reka Pigniczky, a documentary film maker working in the Microlab as temporary assistant. The new version featured interviews with research groups in the Microlab. It was updated once more, in 2001, and can be seen on the Microlab's Archive website, <http://microlab.berkeley.edu/history/HistoricalMaterials.html>.

Labnetwork

From early on, Microlab management paid attention to networking with leaders of other university microlabs. Many visitors came with the intent of finding out how other institutions manage their labs; thus, to help with transferring information, K. Voros and Prof. Ping K. Ko, Faculty-in-Charge (the title was changed to Faculty Director in 1993), wrote an ERL Memorandum, *Evolution of the Microfabrication Facility at Berkeley*, in 1989 [14]. This memo served as a hand-out, along with informational material, to visitors.

Management took conference and other travel opportunities, to visit university labs and to connect with colleagues in the field. These activities were important in creating, with faculty directors and lab managers, an academic laboratory network, in 1995. Berkeley's contact list provided the kick-off for the mailing list, labnetwork@mtl.mit.edu, which developed into a focused, thriving on-line community, exchanging ideas and helping one another.

One of the first activities of the Labnetwork was to provide a communique to the Semiconductor Industry Association (SIA), with comments and feedback on SIA's plans to establish a network of research centers at universities. Also, a Labnetwork poster for SRC Techcon '96 and a White Paper for the LabnetSoftware joint project was compiled. (Details of the Microlab's participation on the latter are described in the *VII. Computer Information and Management System, Development and Upgrades*, on page 89 of this report.) Early labnetwork activities are recorded at <http://www-mtl.mit.edu/labnetwork>.

"Labnetwork people" found a conference-home at UGIM, the University/Government/Industry/Micro-Nano Symposium, which holds its meetings at a different university biennially. The latest one, the 19th, was at Berkeley, in 2012, when the new Marvell NanoLab was showcased. K. Voros has been a member of the Steering Committee since its inception in 1995 and was co-chair with Bill Flounders, of the UGIM 2012 symposium. (Fig. 115.) <http://microlab2.eecs.berkeley.edu/UGIM2012>



Fig. 115. Banner of UGIM 2012 held at UC Berkeley.

Microlab Events

The Microlab had its Dedication Ceremony on March 23, 1983. After that, several important mile stones provided opportunities to for rejoicing and reflecting on accomplishments.

New Staff Office – 1989

As the staff structure of the Microlab became formalized, it grew out of its old, inefficient office and management requested additional space. EECS Chair, Prof. Hodges assigned 409 Cory Hall, adjacent to the Microlab, for office extension.



Fig. 116. View to W. from the new office. (Flat rooftop in forefront was Old Davis Hall, which was replaced by the new CITRIS bldg.)



Fig. 117. Spacious new office, with manager's cubicle in the NW corner (1989).

The old office was consolidated with the additional room and was extensively renovated and equipped with new furniture. In addition, a much needed Storage Room (421) and a Mechanical Services (pump) room (413), was created. This indeed was a cause for celebration, which happened in December 1989. (See Fig. 116-119.)



Fig. 118. Rosemary Spivey, Administrative Supervisor, at the reception desk.



Fig. 119. Marilyn Kushner, who helped organize the reception, at her cubicle.

The Microlab's Tenth Anniversary – March 1993

Ten years after the opening of the Microlab operations were well stabilized, membership growth enabled sustaining the budget and the lab developed a respectable reputation. It was time to celebrate! (Fig. 120-124.)



Fig. 120. Dean David A. Hodges addressing the guests.



Fig. 121. Prof. Spanos, the new Microlab Faculty Director.



Fig. 122. Prof. W. G. Oldham (left), builder of the Microlab, with Prof. D. Angelakos, Director of ERL.



Fig. 123. Prof. Ping K. Ko, Microlab Faculty-in-Charge (1984-1993) received the “Order of the Microlab”.

Fig. 124.
Tenth Anniversary reception
on the 4th floor of Cory Hall
(March 1993).



200 Lab Members Milestone – 1996



Fig. 125. In 1996 Microlab membership reached 200.

After a gradual but steady rise during the first ten years, Microlab membership reached in 1996 an average of 200 per month. Staff, students, and professors gathered to celebrate. (Fig. 125-127.)



Fig. 126. Celebrating 200
members of the Microlab
(1996).

Fig. 127.
BSAC members
celebrating. L-R:
Michael Helmbrecht,
Angad Singh,
Jim Bustillo,
David Horsley,
Roger Hipwell, and
John Evans.



Mortgage burning – August 1997

In 1983 the Microlab had an accumulated debt of \$401,186, left over from the construction of the facility. Starting in FY 88/89, yearly budgets included a proposed \$50K debt recovery, until the obligation was paid off. This happened 10 years later, at the close of FY 96/97. Cause for celebration! (See Fig.128 and 129.)



Fig. 128. Microlab mortgage burning.



Fig. 129. Two PIs, whose lab fees helped pay off the mortgage.
Prof. Pister and C. Chang-Hasnain.

Chancellor Robert M. Berdahl's visit – 1997

UC Berkeley Chancellor from 1997-2004, Robert M. Berdahl, a historian by profession, had to deal with many facilities issues during his tenure, among them renovation and seismic upgrade of the Hearst Memorial Mining Building (1998-2002). He announced an action plan to improve seismic safety on campus and visited many buildings. (See Fig. 130.)



Fig. 130. Chancellor Berdahl's visit in 1997. (L-R) Prof. Paul Gray, Dean of Eng., Prof. Costas Spanos, Microlab Faculty Director, Chancellor Robert M. Berdahl, Prof. Andrew Neureuther, Associate Chair, and Prof. Randy Katz, Chair of EECS.

New MOCVD Lab – 1997

Professors Constance Chang-Hasnain and Kam Y. Lau were the main PIs of another lab Microlab staff helped to build on the first floor of Cory Hall. Alex Para, Special Projects Manager, coordinated the renovation of the facility, which opened in November 1997. (Fig. 131 and 132.)

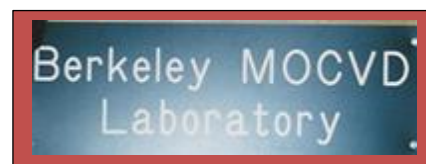
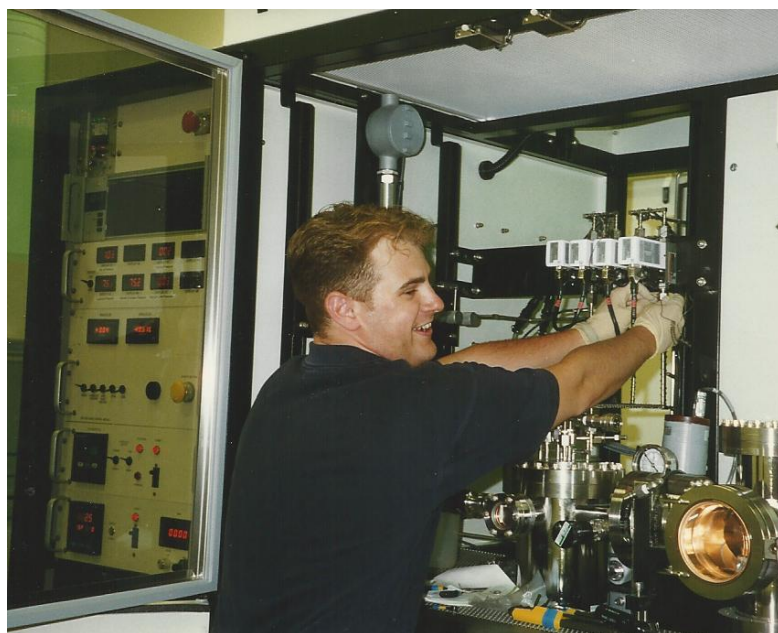

Fig. 131. EMCORE equipment engineer at the new MOCVD system.



Fig. 132. At the opening of the new MOCVD Laboratory. Principal Investigators Prof. K. Lau and Prof. C. Chang-Hasnain with Engineering Dean P. Gray and Prof. E. Haller of MSE

New Faculty Director: Prof. Tsu-Jae King Liu – 2000

After serving seven years as Microlab Faculty Director, Professor Costas Spanos handed over the baton to Professor Tsu-Jae King Liu. (Fig. 133 and 134.)



Fig. 133. Incoming Faculty Director Prof. Tsu-Jae King Liu with Prof. Spanos (2000).

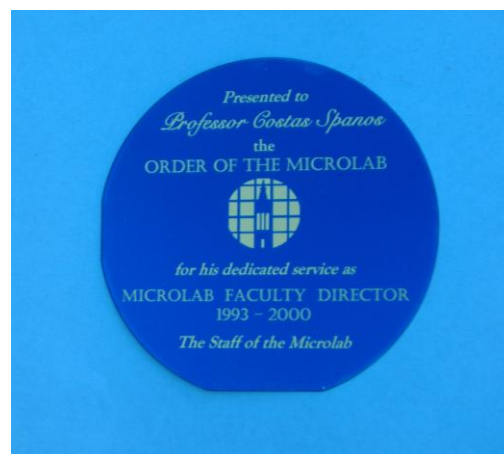

Fig. 134. Professor Spanos received the “Order of the Microlab” at the end of his tenure as Faculty Director.

Device Characterization Lab Renovation – 2001

Burgeoning activities necessitated upgrading the 407/409 Cory Hall metrology and device characterization labs (DCL). HEPA filters and house vacuum were added and new benches, lights and instrumentation were installed. Phill Guillory, Microlab technical supervisor was the lead on this project. The refurbished lab opened in April 2001, to the delight of the device students. (Fig. 135-138.)



Fig. 135. Banner for the opening of the refurbished DCL (2001).



Fig. 136. (L-R) DCL manager graduate students Pushkar Ranade and Kevin Yang, and the three PIs who financed the renovation, Device Group: Prof. Tsu-Jae King Liu and Prof. Chenming Hu, with BCAM (metrology) PI, Prof. Costas Spanos

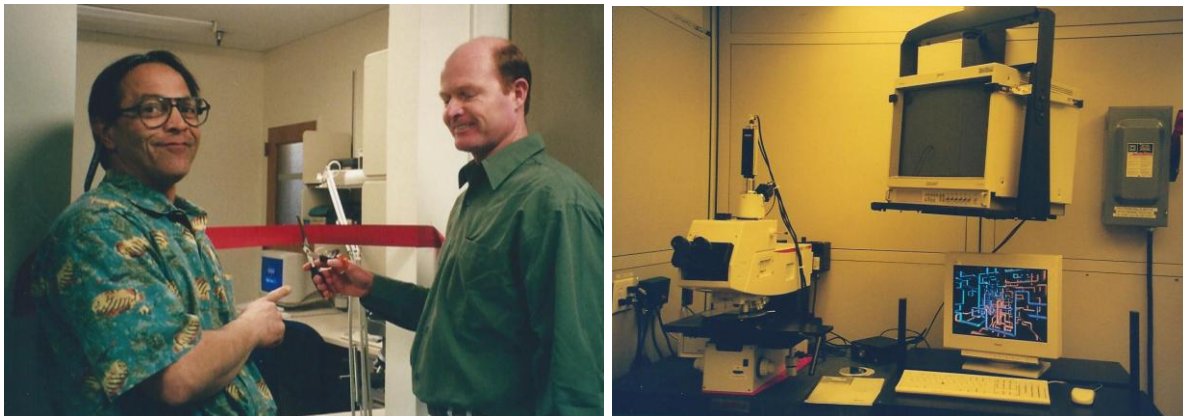

Fig. 137. Phill Guillory (left) and Tim Duncan, BCAM engineer, cut the ribbon of the BCAM Metrology lab, shown on the right.



Fig. 138. Let's have a party!
Microlab Operations Manager thanks all who worked on this project.

Chancellor Robert J. Birgeneau's visit – 2006

Chancellor Birgeneau, 2004-2012, Professor of Physics, visited the Microlab in June 2006. Host W. A. Flounders, Microlab Technology Manager wrote of the event: “The Chancellor spent a full hour hearing from Berkeley faculty about the value to their research that the shared Microlab facility provides and then took a fully gowned laboratory tour. The Chancellor went into every room and asked extensive questions about tool capabilities and laboratory infrastructure. It was a distinct pleasure to host a keen researcher with such a passion for science and it is valuable to the Microlab to have such a champion for our operation.” (Fig. 139.)



Fig. 139. Chancellor Robert J. Birgeneau's visit (2006). (L-R) The Chancellor, Prof. Edward Lee, EECS Chair, Prof. Frances Hellman, Physics Chair, Prof. Shankar Sastry, Dean of Engineering, and Dr. A. W. Flounders, Microlab Technology Manager.

Closing of the Microlab

Microlab operations wound down completely in 2010 when the lab closed at the end of December. The Microlab's Closing Ceremony was held April 2011, connected with a NanoLab Open House. (See Fig. 140.) Master of Ceremonies was former Microlab Faculty Director and EECS Chair, Prof. Costas Spanos. Prof. David Hodges talked about the Integrated Circuits Lab (The Old Lab) 1962 – 1982; Prof. Tsu-Jae King Liu, immediate past Microlab Faculty Director, and Katalin Voros, Microlab Manager from 1986-2010, discussed successes and operations in the Microlab during the past 28 years. At the event Katalin Voros received a *Chancellor's Outstanding Staff Award in 2011*. Then, Prof. Ming Wu, NanoLab Faculty Director and Dr. A. W. Flounders, NanoLab Executive Director, invited the audience for a tour of the new lab, with a reception afterwards. Thus, the story of the Microlab ends.



The poster features a background image of a modern laboratory hallway with glass walls and doors. In the foreground, a white sign hangs from a door handle, reading "CLOSED WE HAVE MOVED". The text is overlaid on the image in blue and white boxes. Two logos are present: a blue circular logo with a white grid and a yellow square logo with a blue grid and a yellow building icon. An inset photograph in the bottom left shows the exterior of a large, modern building with a courtyard.

Berkeley Microlab Closing Celebration
22 April 2011 from 2:00 PM - 3:30 PM
Sibley Auditorium, Bechtel Engineering Center

Reception and Open House
Marvell NanoLab
3:30 PM - 5:00 PM
Sutardja Dai Hall

Fig. 140. Poster of the Microlab's Closing Ceremony (April 2011).

IX. Summary

There were a great many people instrumental to the Microlab's mission of providing a working research environment for graduate students in microelectronics. First, visionary professors in the Department created an integrated circuits lab when the industry was still in its infancy (1962). Their legacy, that a cooperative laboratory can be successful, was the basis for pooling resources again 20 years later, when a modern new lab was needed. Prof. W.G. Oldham led the creation of the physical plant and Prof. Hodges's research provided the virtual environment. Both were essential to the development and success of the Microlab.

The Microlab's history consists of one continuous development. Once construction was completed and equipment was even partially in place, research needs dictated its progress and continued development. The first graduate class in CMOS processing in 1983-84, pushed the lab into "running" mode. This required a computer control system to provide the tools for management. Thus, one project complemented the other. Later, advanced lithography research enabled the 6" upgrade, needed by silicon device and sensors people. Both pushed for expansion of the lab's thin films capability and etching. Tools for these came in through matching grants for manufacturing technology and metrology grants. Cryo-electronics and compound semiconductor researchers developed their own tools for special materials and used common lithography tools and measurement systems.

Departmental leadership recognized at the start that to operate such a complex, cooperative lab, a professional staff was needed. This was put in motion by hiring an experienced process engineer to do the job, and by assigning one interested faculty to oversee it. EECS/ERL required that the facility be self-supporting, but provided financial assistance until the operation could sustain itself. This recipe worked. The Microlab became a well-respected facility, which served over 100 PIs from diverse disciplines and research projects.

Historical Eras of Microlab Operations

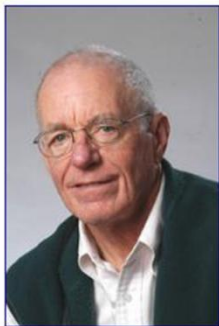

Professor William G. Oldham
Builder of the Microlab
Microlab Faculty-in-Charge
March 1983-June 1984



Professor David A. Hodges
Provider of the cyber-environment through his
Computer Systems Research 1982-1990

Professors Oldham and Hodges, builders of the Microlab, followed with interest and inquiries, as their younger colleagues put their own stamps on the development of the Microlab.

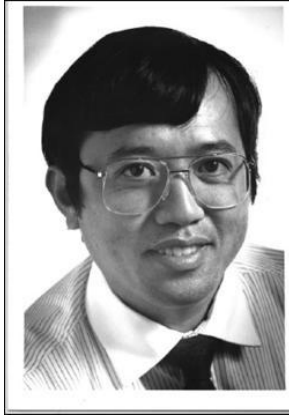

Professor Ping K. Ko
Faculty-in-Charge
July 1984-June 1993

Operational Highlights 1980's

- Development of systems and controls
- Enabling technology: computers (1984)
- Membership development (WAND 1984)
- Staff structure and development (STAFF 1985)
- Equip. control and development (FAULTS 1989)
- Facilities stabilization (BLIMP 1988)
- Financial analysis and control (Acct 1984)
- Reports: Evolution of the Microlab (1989), YER, FYER



Professor Costas J. Spanos
Faculty Director
July 1993-June 2000

Operational Highlights 1990's

- CMOS Baseline established (1992)
- Integrated Materials Lab established (1993-2004)
- Tenth anniversary celebration, new booklet (1993)
- Solid State Devices and Technology seminars (1994)
- Machine Shop under ML management (1994)
- BCIM2.0 released, ERL report (1995)
- Affiliates program established (BMLA 1996)
- Membership passed 200, looking for new lab (1996)
- Mortgage burning (1997)
- Planning for 6" upgrade (1998)
- Microlab videos: 1989, 1995, 2001, Safety: 2000



Professor T- J. King Liu
Microlab Faculty Director
July 2000-June 2008



Prof. Nathan W. Cheung
Interim Faculty Director
August 2004-July 2006



Prof. Ming C. Wu
Faculty Director
July 2008-Dec. 2010

Operational Highlights 2000's

- **New CITRIS building approved, with lab (2001)**
- **Device characterization, metrology lab renovation (2001)**
- **Equipment control upgrade, WIS (2001)**
- **Summer intern program (2001)**
- **6" upgrade (completed 2004, 6-year project)**
- **Planning for the NanoLab (2004-2008)**
- **Move to the NanoLab (2009-2010)**
- **Closing of the Microlab (December 2010)**
- **Microlab Closing Ceremony (April 2011)**

X. References

- [1] "New Lab at UC," *IEEE Grid*, 15 Feb. 1964.
- [2] Rigby, G. A (editor), "Integrated Circuits Laboratory Manual," ERL Memorandum No. ERL-M197, University of California, Berkeley, 1967.
- [3] W. Oldham, "The Berkeley Microfabrication Facility, EECS/ERL Research Summary," Industrial Support Office, University of California, Berkeley, 1984.
- [4] ERL, "The Berkeley Microfabrication Facility," EECS/ERL Industrial Support Office, University of California, Berkeley, August 1985.
- [5] ERL, "CAD/CAM Facility," EECS/ERL Industrial Support Office, University of California, Berkeley, Sep. 1985.
- [6] ERL, "Microfabrication Laboratory Dedication - March 23, 1983," Department of Electrical Engineering and Computer Sciences, Electronics Research Laboratory, University of California, Berkeley, 1983.
- [7] W. G. Oldham, A. R. Neureuther, Y. Sacham, et al., "Berkeley CMOS Process Test Patterns," ERL Memorandum No. UCB/ERL M84/26, University of California, Berkeley, March 1984.
- [8] W. G. Oldham, A. R. Neureuther, Y. Sacham, F. Dupois, "Berkeley CMOS Process - A User Guide," ERL Memorandum No. UCB/ERL M84/84, University of California, Berkeley, October 1984.
- [9] K. Voros, "A New 10:1 Phomask Reduction Camera," MS Report, Department of Electrical Engineering and Computer Sciences, University of California, Berkeley, Dec. 1984.
- [10] Katalin Voros and Ping K. Ko, "MOS Processes in the Microfabrication Laboratory," ERL Memorandum No. UCB/ERL M87/12, University of California, Berkeley, March 1987.
- [11] R. Alley, P.K. Ko, K. Voros, "Characterization of the Boron+ Planar Dopant Source Moisture Enhanced Process," ERL Memorandum No. UCB/ERL M86/75, University of California, Berkeley, September 1986.
- [12] Lawrence A. Rowe and Christopher B. Williams, "An Object-Oriented Database Design for Integrated Circuit Fabrication," ERL Memorandum No. UCB/ERL M87/43, University of California, Berkeley, May 1987.
- [13] M. G. d. C. Resende, "Shop Floor Scheduling of Semiconductor Wafer Manufacturing," Ph.D. Dissertation, Department of Industrial Engineering and Operations Research, University of California, Berkeley, 1987.
- [14] Ping K. Ko and Katalin Voros, "Microfabrication at Berkeley," EECS/ERL Industrial Liaison Program, University of California, Berkeley, 1987.
- [15] Ping K. Ko, Robin R. Rudell, K. Voros, "EECS 143 Processing and Design of Integrated Circuits Laboratory Project," ERL Memorandum No. UCB/ERL M88/50, University of California, Berkeley, August 1988.
- [16] P. M. Krueger, "Tuning a Statistical Process Simulator to a Berkeley CMOS Process," ERL Memorandum No. UCB/ERL M88/82, University of California, Berkeley, December 1988.

- [17] J. M. Huggins, "Secrets of the Berkeley Sensor & Actuator Center (BSAC)," EECS Technical Report No. UCB/EECS-2013-26, University of California, Berkeley, April 2013.
- [18] A. Sharma, "Berkeley Fabrication Facility Monitoring System," MS Report, Department of Electrical Engineering and Computer Sciences, University of California, Berkeley, 1988.
- [19] A. C. West, "FLIP: A Graphic Use-Interface for Management and Utilization of Facilities," ERL Memorandum No. EECS/ERL M89/39, University of California, Berkeley, April 1989.
- [20] Katalin Voros and Ping K. Ko, "Evolution of the Microfabrication Facility at Berkeley," ERL Memorandum No. EECS/ERL M89/109, University of California, Berkeley, September 1989.
- [21] Chia-Ray Ni, "A Tool for Collection of I-V Statistics Using the HP 4062 Semiconductor Parametric Test System," ERL Memorandum No. UCB/ERL M90/7, University of California, Berkeley, January 1990.
- [22] ERL, "Putting it together in the Microlab," *EECS/ERL News*, pp. 10-11, Fall 1990.
- [23] Lawrence A. Rowe, Christopher B. Williams, and Christopher J. Hegarty, "The Design of the Berkeley Process-Flow Language," ERL Memorandum No. UCB/ERL M90/62, University of California, Berkeley, July 1990.
- [24] N. H. Chang, "Monitoring, Maintenance and Diagnosis in a Computer-Integrated Environment for Semiconductor Manufacturing," PhD Thesis, EECS Department, University of California, Berkeley, 1990.
- [25] D. C. Mudie, "FAULTS: An Equipment Maintenance and Repair Tracking System Using a Relational Database," ERL Memorandum No. UCB/ERL M91/44, University of California, Berkeley, May 1991.
- [26] "CSM - Competitive Semiconductor Manufacturing Program," [Online]. Available: <http://microlab.berkeley.edu/csm/>.
- [27] UCB/EECS, Reserach Software, Berkeley: University of California, EECS Industrial Liaison Program, 1992, 1994-1995.
- [28] Costas J. Spanos, Katalin Voros, "Microfabrication at Berkeley," EECS/ERL Industrial Liaison Program, University of California, Berkeley, March 1993.
- [29] D. Rodriguez, "Electrical Testing of a CMOS Baseline Process," ERL Memorandum No. M94/63, University of California, Berkeley, August 1994.
- [30] COE, "EECS at Berkeley," College of Engineering, University of California, Berkeley, 1994.
- [31] S. Fang, "CMOS Baseline Process in the UC Berkeley Microlab," ERL Memorandum No. UCB/ERL M95/98, University of California, Berkeley, December 1995.
- [32] L. J. Massa-Lochridge, "BCIMS: The Berkeley Computer Integrated Manufacturing System," ERL Memorandum No. UCB/ERL M95/46, University of California, Berkeley, June 1995.
- [33] Kirt R. Williams and Richard S. Muller, "Etching for Micromachining Processing," ERL Memorandum No. UCBERL M96/37, University of California, Berkeley, June 1996.
- [34] "MNX | MEMS and Nanotechnology Exchange," [Online]. Available: <https://www.mems-exchange.org/>.

- [35] L. Voros, "CMOS Baseline Process in the UC Berkeley Microfabrication Laboratory Report II," ERL Memorandum No. UCB/ERL M00/61, University of California, Berkeley, December 2000.
- [36] K. Voros, "Hop on Board with Safety," in *Fourteenth Biennial University/Government/Industry Microelectronics Symposium Proceedings*, Virginia Commonwealth University, Richmond, Virginia, 2001.
- [37] "Badger Lab Management System," [Online]. Available: <http://snf.stanford.edu/labmembers/badger.htm>.
- [38] "Microfabrication at Berkeley - 2001 (video)," 2001. [Online]. Available: <http://microlab.berkeley.edu/history/HistoricalMaterials.html>.
- [39] L. Voros and S. Parsa, "Six-Inch CMOS Baseline Process in the UC Berkeley Microfabrication Laboratory," ERL Memorandum No. UCB/ERL M02/39, University of California, Berkeley, December 2002.
- [40] "UGIM 2012," 2012. [Online]. Available: <http://ieeexplore.ieee.org/xpls/icp.jsp?arnumber=6247079>.
- [41] T. Duncan, T.K. Chen, D. Pestal and T. Merport, "RUMS - Resource Utilization Monitoring System," ERL Memorandum No. ECB/ERL 03/43, University of California, Berkeley, November 2003.
- [42] "Microfabrication Laboratory Portal," [Online]. Available: <http://microlab.berkeley.edu/people/staffpage.html>.
- [43] "6" Upgrade Final Report (2004)," 2004. [Online]. Available: <http://microlab.berkeley.edu/text/6inchup/finalrpt.html>.
- [44] A. Horvath, S. Parsa, H. Y. Wong, "0.35 um CMOS process on Six-Inch Wafers, Baseline Report IV," ERL Memorandum No. UCB/ERL M05/15, University of California, Berkeley, April 2005.
- [45] A. Pongracz, G. Vida, "0.35um CMOS Process on Six-Incs Wafers, Baseline Report V.," EECS Technical Report No. UCBECS-2007-26, University of California, Berkeley, February 2007.
- [46] "Marvell Nanofabrication Laboratory," 2008. [Online]. Available: <http://nanolab.berkeley.edu/>.
- [47] "The Marvell Lab Story - 2008 (video)," [Online]. Available: <http://microlab.berkeley.edu/history/HistoricalMaterials.html>.
- [48] Laszlo Petho, Anita Pongracz, "0.35 um CMOS Process on Six-Inch Wafers, Baseline Report VI.," EECS Technical Report No. UCB/EECS-2008-168, University of California, Berkeley, December 2008.
- [49] L. Petho, "0.35 um Processon Six-Inch Wafers, Baseline Report VII.," EECS Technical Report No. UCBECS-2009-163, university of California, Berkeley, December 2009.
- [50] A. Szucs, "0.35 um CMOS Process on Six -Inch Wafers: The First Baseline Run in the New Marvell NanoLab, Baseline report VIII.," EECS Technical Report No. UCB/EECS-2012-118, University of California, Berkeley, May 2012.
- [51] "International SiGe Technology and Devices Meeting," 2012. [Online]. Available: http://www-device.eecs.berkeley.edu/istdm2012/2012_ISTDM/General_Information.html.

- [52] "UGIM 2012 19th Biennial University/Government/Industry/Micro-Nano Symposium," 2012. [Online]. Available: <http://microlab2.eecs.berkeley.edu/UGIM2012>.
- [53] J. R. Whinnery, "Researcher and Educator in Electromagnetics, Microwaves and Optoelectronics, 1935-1995; Dean of College of Engineering, UC Berkely, 1959-1963," in *an oral history conducted in 1994 by Ann Lage*, Berkeley, Oral History Office , The Bancroft Library, University of California, 1966, p. 224.
- [54] "Berkeley Research," University of California, 2012. [Online]. Available: <http://vcresearch.berkeley.edu/research-units>.
- [55] "UC Berkeley - Engineering Research Support Organization," 2012. [Online]. Available: <http://www.erso.berkeley.edu>.
- [56] G. J. Maslach, "Aeronautical Engineer, Professor, Dean of the College of Engineering, Provost for Professional Schools and Colleges, Vice Chancellor for Research and Academic Affairs, University of California, Berkeley, 1949 to 1983," in an oral history conducted in 1998 and 1999 by Eleanor Swent, Regional Oral History Office, The Bancroft Library, University of California, Berkeley, 2000.
- [57] K. S. Pister, "University of California, Berkeley, College of Engineering, Professor and Dean; UCSC Chancellor; Universitywide Chair of the Academic Council and Vice President - Educational Outreach, 1952-2003," in an oral history conducted by Germaine LaBerge in 2000-2003, Regional Oral History Office, The Bancroft Library, University of California, Berkeley, 2003.
- [58] D. A. Hodges, "Oral History: Interviews with David A. Hodges," Interviews conducted by Christophe Lecuyer between June 2008 and June 2010, Berkeley, 2004.

XI. Photo Gallery

The following are selected photos by Marilyn Kushner from the Microlab archives.
(Words in italics are the computer login names of equipment.)



1983 Fall – Rick Spickelmier, Albert Wu, Kai-Yap Toh, Carl Galewski, and John Chern, members of the first class, 290N/290O, in the Microlab.



1983 – Bob Monteverde (EE290) at the gcaws.



Tylan engineer Henry Heidbreder and graduate student Ih-Chin Chen.



1984 Fall – EE143
 Homayoon Ansari and Tong-Chern Ong, Graduate Teaching Assistants, and
 Katalin Voros, Head TA, in the EE143 lab.



1984 Fall – EE143 tech support, Manny Fernandes, and Lisa Gertzis, TA.



1986 – Albert Wu and Robin Rudell.



1896 – Graduate student Carl Galewski and Prof. Ping Ko.



1986 – Graduate Student Myra Boenke in the “old lab”.



1986 – T. C. Ong, Jim Chung, and Tung-Yi Chan in the DCL.



1986 – Tom Muller, student programmer.



1986 – Bob Hamilton and his maintenance crew are taking care of utilities. Phill Guillory in the Taurus chase, connecting wiring for equipment control, and Dick Chan at the DI water system. Below: delivery of the donated CPA sputtering tool, Jose Rivera of the Machine Shop driving.





1987 – ChemE graduate student Bill Flounders at the probe station.



Cryo-electronics GRA David Chin working in the “old lab”.



1987 – Device student Jim Moon at *sink6*.

(Below) BSAC student Leslie Field measuring wafer flatness.





Jurgen Roedel at the *ptherm*. Student at the legacy tool *v401*. Chris Hegarty at the *gcaws*.



1987 – BSAC students Bill Tang (L), Abe Lee, Bob Ried, James Yeh, and Carlos Mastrangelo.



Compound semiconductors GRA Ming Wu. Semiconductor manufacturing GRA Gary May.



1987 – Bob Hamilton’s 25th employment anniversary.
(L-R) Profs. John Whinnery, Dodge Angelakos, Ping Ko, and Bob.



(L-R) Prof. Cheung and the staff of the Machine Shop, Bob Collins, John Tombaugh, Ben Lake, Sam Higginbotham and Jose Rivera.



Staff, students, and professors at Bob’s celebration.
(L-R) Microlab staff James Parrish, Kim Chan, Marilyn Kushner, graduate student Stuart Wenzel, Robin Rudell behind Katalin Voros, Prof. C. W. Tobias of Chemical Engineering and Prof. Chenming Hu of EECS, with graduate student Albert Wu.



1989 – James Parrish in the newly refurbished mechanical services room, “pump room” (413).



Rolfe Anderson (ChemE) working at the *reichert*.



1989 – Kris Pister processing and Dave Giandomenico testing.



1989 – Advanced lithography (DUV) researchers Richard Hsu and Chris Spence at the experimental *ultratech* tool.



Jack Kingston at the “old” exposure tool, *canon*



1989 – Brett Martin at the *randex*.

Gyula Nagy behind the ion implanter, just before it was decommissioned in 1989.





1990 – Kristen McNair and Charles Hsu at the ever popular *technics-c*.



1990 – Bill Partlo and Anton Pfau at the *gcaws*. Tariq Haniff and Valerie Wong at the *ellips*



1991 – BSAC students Liwei Lin and Dave Monk.



Vadim Gutnik at the Nanometrics SEM.



1991 Fall semester
Graduate teaching assistant Jay Tu
with EE 143 class in the Microlab.

1992 – Microlab computer
programmer/analysts
(L-R) Mark Kraitchman
and Christopher Hylands.





1992 – Klaus Schuegraf is still processing.



1992 – Kris Pister is done.



1992 – John Krick and Katalin Voros at the probe station.

Below: Pei-Chun Cho at *sink8*.





1992 – Peter Chen and Kirt Williams, BSAC GRAs.



Sung Han in the “old lab”.

1992 – Annabel Nickels
and Jim Bustillo of BSAC



1992 – John Hutchinson (left)
and Keiko Hatori.



1992 – Prof. Oldham with prospective student and staff research associate Kim Chan (L).



1992 – Gary Fedder (L) and Peter Krulevich of BSAC.



1992 – James Yeh in protective gear, ready for etchig.



1992 – Brothers Jack (L) and Mike Judy.
Jack graduated in 1996 (Prof. Muller), Mike in 1998 (Prof. Howe).



1992 – Happy lab members: (L-R) Joey Talghader, Carey Pico, Erin Jones, and Jian Chen.



1993 – Cleanfest
(L) Anita Flynn and crew.

1993 – Cleanfest
Scrub down inside and
outside. Kirt Williams (R).



1993 – Cleanfest
Lilac Muller polishing
work surfaces in VLSI
and Tom Coleman
vacuuming in the
“old lab”.



1994 – (L) Spanos GRAs Sherry Lee, Antonio Miranda. Xiang Zhang from ME.



(L) Prof. White at *bigblue*

and his student Rich Moroney (R).



1994 – Post Doc. Norman Tien (L).

Visiting researcher from Erlangen, Ernest Kreysa (R).





1995 – Cryo-electronics researchers Xiaofan Meng, Anu Bhat, and their PI, Prof. Van Duzer.



1995 – BSAC researchers (L-R) Olav Solgaard, Michael Cohn, and Kyle Leboutitz.



1995 – (L-R) Trey Roessig, Jay Tu, Clement Wann.

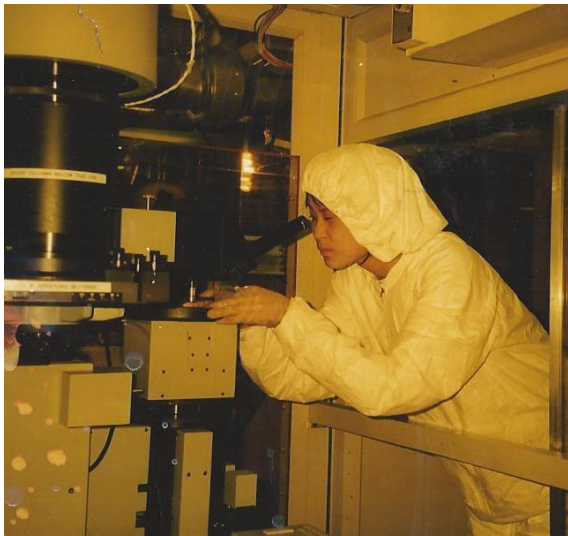

1995 – Students at exposure tools: Amy Wang at the *gcaws* and Tom Lee at the *canon*.



1996 – BSAC students from ME: (L-R) Roel Dieron, Niel Talbot, and David Horsley.



1996 – David Lieberman from UCSD.



Henry Hieselmair, GRE in MSE.



1996 – Gloria Bruner, Greg Cardinale, and Don DeVoe.





1997 – Behrang Behin and Jan Gildemeister.



1997 – Students from UCSD with a successful wafer. (R) BSAC student Uthara Srinivasan.



1998 – Andrea Franke in the lab and at the departmental flower show.



1998 – Roger Su never left the Microlab. First an undergrad. assistant, then staff, then BMLA member.



Device researcher Hideki Takeuchi.



1999 – Pushkar Ranade in VLSI.



Derek Hans at the Tystar LPCVD furnaces.



1997 – Cliff Knollenberger and Michel Maharbiz.



Meng-Hsiung Kiang and Boris Stoeber.



2000 – George Dougherty, Mason Freed, Runzi Chang, and Jocelyn Nee.



2001 – Nick Lindert, Pamela Caton, and Will Holtz.



2001 – Prof. Muller opens the refurbished coffee room (411 Cory Hall).



Ferenc Kovac, manager of the EECS Electronics Support Group, just before the renovation started.



The proud project manager of the renovation, Phill Guillory, showing off the final product.



2002 – DUV photolithography team – success!



2002 – Veljko Milanovic, Katherine Dunphy, Daniel Queen, and on the right, Microlab Faculty Director, Prof. Tsu-Jae King Liu.

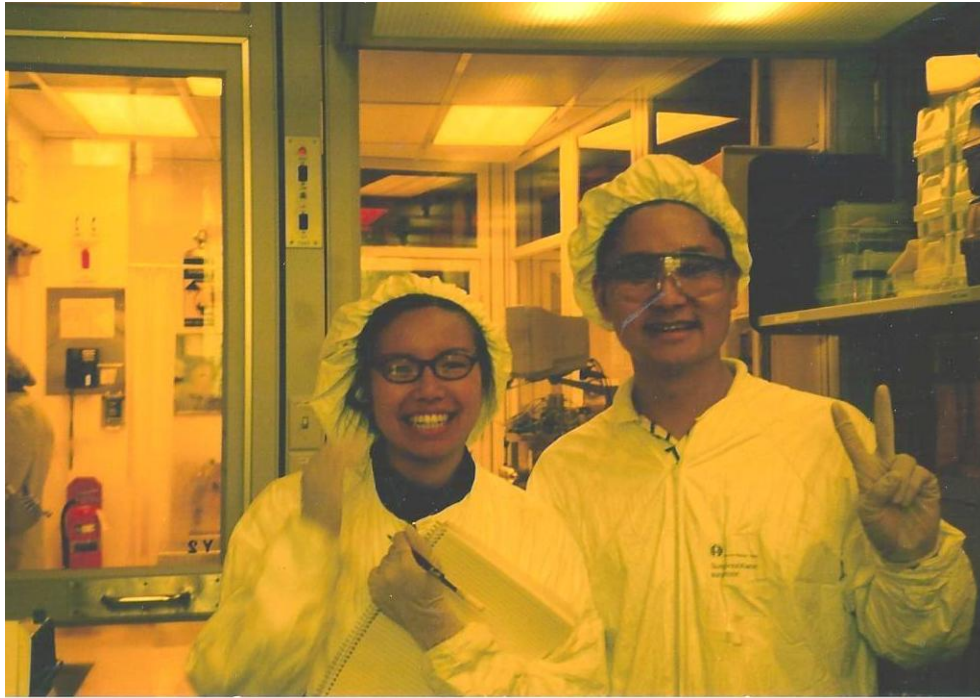

2003 – We survived the six-inch upgrade!



Alvaro Padilla and Frank Zandejas



2005 – (L-R) BSAC students Sha Li and Carolyn White.

Rosanna Combie from LBNL.



2006 – Kristine Rosfjord and Marie-Ange Eyoum.



2007 – John Wasserbauer, Sarah Felix, and Andy Miner.



2008 – Eric Darmstaedter, Ryan Chu, and BMLA member Min He.



2008 – GRA Lindsey Miller, BMLA member Min She, and visiting researcher Attila Szabó.



2009 – ME student Kelly Cherrey.



Physics students Zoe Boekelheide and Chloe Baldasseroni (R).



2009 – Hungta Wang and Jinyao Tang, postdocs in Chemistry with Prof. P. Yang, now asst. profs at the University of Alabama and Hong Kong University.

2010 - The Microlab closed in Cory Hall, moved and became the Marvell NanoLab in Sutarjda Dai Hall.



April 2011 – Prof. Roger Howe and Katalin Voros,
(office mates in 1983-84)
after the Microlab Closing Celebration.

Acknowledgements

Serving as manager of the Microlab was the greatest adventure of my life and I would like to thank the University of California for the opportunity. Within my immediate circle, I am grateful to the Department of EECS/ERL for supporting my position throughout the life of the Microlab, for allowing me to work with the best faculty directors ever, and for giving me the chance to develop the lab, with their leadership, to the best I knew how.

I would like to thank Prof. W. G. Oldham for being my research director during my MS studies, which coincided with the construction of the Microlab. My project required me to work daily in the Cory Hall Machine Shop for a semester, an invaluable experience as preparation for managing the Microlab, and later, the Machine Shop, too. Thanks also for recruiting me as head TA for EE143; another very useful experience, considering that the Microlab supported this class for 28 years afterwards.

I would like to express my deepest gratitude to Prof. D. A. Hodges, who was an enthusiastic and unwavering supporter of the Microlab throughout, and a mentor to its manager, me. Thank you for inviting me to participate in the Competitive Semiconductor Manufacturing research project; it was reassuring to see that the Microlab was on track with the semiconductor industry. It was a pleasure to meet many of our alumni and to know that the Microlab provided them with useful skills for their careers.

I wish to express my sincere and profound gratitude to the Microlab's great Faculty Directors, Prof. Ping K. Ko (1984-1993), Prof. Costas J. Spanos (1993-2000), and Prof. Tsu-Jae King Liu (2000-2008), each of whom accepted this responsibility for a time way longer than a normal committee assignment. They genuinely cared about the Microlab, which made working with them a pleasure. We were on the same wavelength from the start; their interest, advice, and contributions were forthcoming when most needed. At the same time, they allowed me to develop my own ideas and to implement them without micro-managing. I could not have wished for better bosses. Thank you Ping, Costas, and Tsu-Jae!

Thank you Prof. Nathan Cheung for being a cheerful Interim Faculty Director during Prof. King Liu's industrial leave (2004-2006) and thank you Prof. Ming Wu for accepting the position for the last two years of the Microlab – after Prof. King Liu was named Associate Dean for Research.

A major component of the Microlab's success was the work of its long-term, dedicated staff. Five colleagues started and closed the lab with me: Kim Chan, Phill Guillory, Bob Hamilton, Marilyn Kushner, and Rosemary Spivey. It is my great fortune to have had Bob and Rosemary helping me manage the myriad aspects of the operation, to have Phill take care of utilities and a broad range of facilities issues, and to have Kim and Marilyn as processing experts. We all learned and grew together, in our respective positions, working for the same goal, to make the Microlab the best university lab possible. Thank you each for your dedicated good work.

Early in the Microlab's history Robin Rudell was a great contributor as the first process supervisor. Thank you, Robin, for jumping in with full energy and the right spirit when we needed it most. Sia Parsa, Process Engineering Manager, came on board at the halfway point in the life of the Microlab and became the pillar of processing activities. He identified with the mission of the Microlab immediately and by the time we closed the doors it seemed like he had been here from the start. Thank you Sia for your enthusiasm and devoted work.

My appreciation goes to Susan Kellogg-Smith, Purchasing Manager, Rosemary Spivey's dedicated right hand from early on, who managed supplying the Microlab steadily with over 1700 inventory items for 21 years. Her understanding that the Supplies and Expenses portion of the budget was approximately half of the total, made her the best buyer we could have wished for. As the Microlab grew, Susan trained her assistant, Adrienne Ruff, who continued in the discipline expected by management. Thank you both, for enabling the smooth operation of the lab.

Bob Hamilton's staff was the largest because it had the largest and most complex job of all, keeping more than 130 pieces of processing equipment up and the utilities needed to operate them, running – 24/7. Besides Phill Guillory, Bob managed several technicians who left after the early stages of the Microlab. Two, who came early and became stalwarts and valued employees, were Evan Stateler, electronics expert and Mike Linan, vacuum and general equipment specialist. The final group, who moved with the lab to the new home, the NanoLab, were: Joe Donnelly, David Lo, Bryan McNeil and Danny Pestal, all with over ten years of employment with the Microlab, also Jay Morford and Al Briggs. I thank you all.

Special thanks go to the staff of the Machine Shop, under the management of Ben Lake; without them the Microlab could not have existed. During the start-up, the expansion into satellite labs, the 6" upgrade, and the move into the new lab, the Machine Shop became the extension of the Microlab. My true appreciation goes to all of them, Ben Lake, Joe Gavazza, Bob Amaral, Lou Ahtty, and Bill King. The Machine Shop and I owe a great debt to Nancy Peshette, Administrative Assistant, whose special knowledge of machine shop tools and procedures helped make it into a successful operation.

Computer people are a special breed. I learned soon that they work best, and way over expectations, when left alone and not forced into the 8-5 routine. First my thanks go to the graduate student researchers who designed and developed the Microlab's first management information system. They are listed on page 65. I want to express my special thanks and appreciation to Christopher Williams, who was the main supporter of the systems during their deployment in the Microlab, a real-time operation. He was called upon untold times and he worked on the problems, bugs and improvements requested, without a word of complaint. He was easy going, always cheerful and agreeable, and worked well with Microlab staff.

An outstanding, talented Programmer/Analyst, David Mudie, worked for the Microlab first, then completed his MS degree, then came back as staff. He made the equipment maintenance staff and me, learn the discipline required to build an expert system – if we wanted one. We did and provided the information for him to build FAULTS, the equipment information and management system. It is still in use. Thank you, David.

Mark Kraitchman and Christopher Hylands held the computer fort while David Mudie was in school. Lab operations did not tolerate down-times and they maintained our systems in top form. Thank you both. I would also like to thank Tim Duncan for his creativity in adding the capability of managing the satellite labs through the Microlab's computer system.

My special thanks and gratitude go to Todd Merport with whom I worked during the last ten years, much of which was taken up by the design and development of a new information system, Mercury, for the NanoLab. First we worked with the Labnetwork people on a joint project. Much of the technical details of the design were way over my head, but I learned soon to trust Todd's expertise in the technology. I also relied heavily on his and his staff's opinion to leave the joint project and to go on our own; I took their advice and never looked back. Olek Proskurowski came half-way through the project and contributed the idea of Mercury Web. I thank him for his patience and perseverance in convincing us that this approach would be useful in simplifying our complex system. It worked. Thanks, Olek!

Prof. Spanos was my wise Faculty Director who created the position of Technology Manager, without me realizing that I had over-extended myself and that the Microlab's future would need one. Jim Bustillo, who was the first (1996-2000), was an absolute delight to work with. He was already in the Microlab as BSAC's development engineering manager. He stepped into the half-time Microlab position without a ripple. This was a period of expansion in the lab. Jim spearheaded the 6" upgrade and initiated and managed the MEMS Exchange program – a nice revenue generator for the Microlab.

After Jim resigned, Bill Flounders joined our ranks. He, too, in a shared position with BSAC, and then, when the new lab plans became reality, full time. Bill was not new to the Microlab; he was a Microlab alumnus, who was enthusiastic to be back. He took on the responsibility of following the development of the new lab, went to countless design meetings, dealt with Capital Projects and the general contractor, and did everything he possibly could to ensure we would end up with a wonderful new lab. We did. Thank you, Jim and Bill, for identifying with our goals from day one and for working hard to realize them.

I left the two most important persons for last. That is because I owe them the greatest amount of thanks and gratitude. I am forever indebted to them, because without Bob Hamilton and Rosemary I could not have managed the Microlab. The knowledge that they know, much more than I ever could know, their respective fields, facilities maintenance and development, and university administration, and that I could have absolute trust in their dedication to our unit, left me free to do the rest that was needed to make the Microlab a first class operation – the subject of this report.

I ran the Microlab to the best of my knowledge and wrote this account of our activities as I experienced them. I hope that my interpretations are close to those of others who were part of the operation and of those who were supporters, the more than 100 PIs and their graduate students the Microlab served.

K.V.

Biography



Katalin Voros graduated from the Drexel Institute of Technology (Philadelphia) in 1966 with a B.S. degree in Physics. She worked as a process engineer for Philco-Ford Microelectronics (bipolar ICs), Solid State Scientific, Inc. (RF transistors, CMOS circuits), and Microwave Semiconductor Corporation (high frequency power transistors). She joined RCA's David Sarnoff Research Center in Princeton, New Jersey in 1980 as an associate member of technical staff, in high density bulk CMOS (SRAM) development.

In 1984 Ms. Voros received her MS degree in Engineering Science in the Department of Electrical Engineering and Computer Sciences at the University of California, Berkeley, where she was retained in the Microfabrication Laboratory as a process development engineer. A Principal Development Engineer, Ms. Voros was Operations Manager of the UC Berkeley Microlab, from 1986-2010. She also participated in an inter-departmental research group studying competitive manufacturing in the semiconductor industry. She retired as R&D Engineering Manager in June 2013.

Ms. Voros is a member of the Electrochemical Society, and a Senior Life Member of IEEE. She is a recipient of the University of California, Berkeley, Administrative & Professional Staff Distinguished Achievement Award (1991), the Berkeley Staff Assembly's Excellence in Management Award (1995 and 2001) and the Chancellor's Outstanding Staff Award (2011). She received the Gold Cross of Merit of the Republic of Hungary in 2009. After 30 years with the University of California, Berkeley, upon retirement Katalin Voros had been conferred the title R&D Engineering Manager Emerita.