

The Euler spiral: a mathematical history

Raph Levien



Electrical Engineering and Computer Sciences
University of California at Berkeley

Technical Report No. UCB/EECS-2008-111

<http://www.eecs.berkeley.edu/Pubs/TechRpts/2008/EECS-2008-111.html>

September 2, 2008

Copyright 2008, by the author(s).
All rights reserved.

Permission to make digital or hard copies of all or part of this work for personal or classroom use is granted without fee provided that copies are not made or distributed for profit or commercial advantage and that copies bear this notice and the full citation on the first page. To copy otherwise, to republish, to post on servers or to redistribute to lists, requires prior specific permission.

The Euler spiral: a mathematical history

Raph Levien

August 30, 2008

Abstract

The beautiful Euler spiral, defined by the linear relationship between curvature and arclength, was first proposed as a problem of elasticity by James Bernoulli, then solved accurately by Leonhard Euler. Since then, it has been independently reinvented twice, first by Augustin Fresnel to compute diffraction of light through a slit, and again by Arthur Talbot to produce an ideal shape for a railway transition curve connecting a straight section with a section of given curvature. Though it has gathered many names throughout its history, the curve retains its aesthetic and mathematical beauty as Euler had clearly visualized. Its equation is related to the Gamma function, the Gauss error function (erf), and is a special case of the confluent hypergeometric function.

This report is adapted from a Ph. D. thesis done under the direction of Prof. C. H. Séquin.

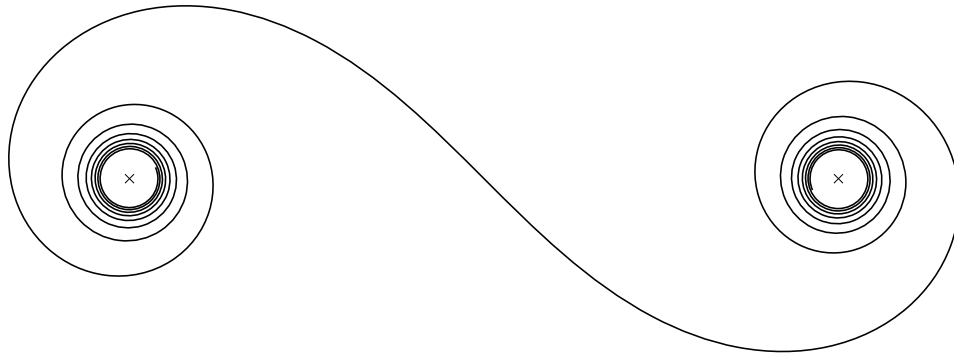

Figure 1: Euler's spiral.

1 Introduction

This report traces the history of the Euler spiral, a beautiful and useful curve known by several other names, including “clothoid,” and “Cornu spiral.” The underlying mathematical equation is also most commonly known as the Fresnel integral. The profusion of names reflects the fact that the curve has been discovered several different times, each for a completely different application: first, as a particular problem in the theory of elastic springs; second, as a graphical computation technique for light diffraction patterns; and third, as a railway transition spiral.

The Euler spiral is defined as the curve in which the curvature increases linearly with arclength. Changing the constant of proportionality merely scales the entire curve. Considering curvature as a signed quantity, it forms a double spiral with odd symmetry, a single inflection point at the center, as shown in Figure 1. According to Alfred Gray, it is “one of the most elegant of all plane curves.” [13]

2 James Bernoulli poses a problem of elasticity–1694

The first appearance of the Euler spiral is as a problem of elasticity, posed by James Bernoulli in the same 1694 publication as his solution to a related problem, that of the elastica.

The elastica is the shape defined by an initially straight band of thin elastic material (such as spring metal) when placed under load at its endpoints. The Euler spiral can be defined as something of the inverse problem; the shape of a pre-curved spring, so that when placed under load at one endpoint, it assumes a straight line.

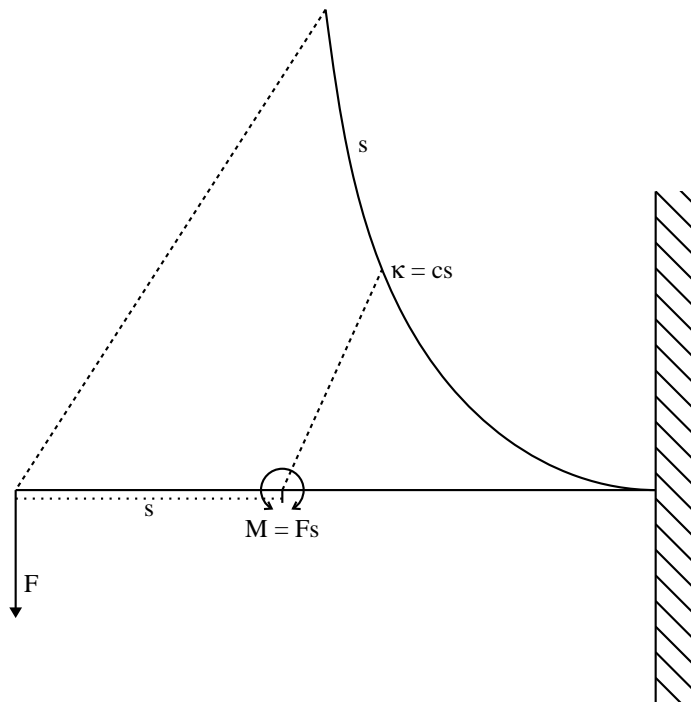

Figure 2: Euler’s spiral as an elasticity problem.

The problem is shown graphically in Figure 2. When the curve is straightened out, the moment at any point is equal to the force F times the distance s from the force. The curvature at the point in the original curve is proportional to the moment (according to elementary elasticity theory). Because the elastic band is assumed not to stretch, the distance from the force is equal to the arclength. Thus, curvature is proportional to arclength, the definition of the Euler spiral.

James Bernoulli, at the end of his monumental 1694 *Curvatura Laminae Elasticae*¹, presenting the solution to the problem of the elastica, sets out a number of other problems he feels may be addressed by the techniques set forth in that paper, for example, cases where the elastica isn’t of uniform density or thickness.

A single sentence among a list of many, poses the mechanics problem whose solution is the Euler spiral: To find the curvature a lamina should have in order to be straightened out horizontally by a weight at one end².

¹*Curvatura Laminae Elasticae. Ejus Identitas cum Curvatura Lintei a pondere inclusi fluidi expansi. Radii Circulorum Osculantium in terminis simplicissimis exhibiti, una cum novis quibusdam Theorematis huc pertinentibus, &c.*”, or “The curvature of an elastic band. Its identity with the curvature of a cloth filled out by the weight of the included fluid. The radii of osculating circles exhibited in the most simple terms; along with certain new theorems thereto pertaining, etc.”. Originally published in the June 1694 *Acta Eruditorum* (pp. 262–276), it is collected in the 1744 edition of his *Opera* [3, p. 576–600], now

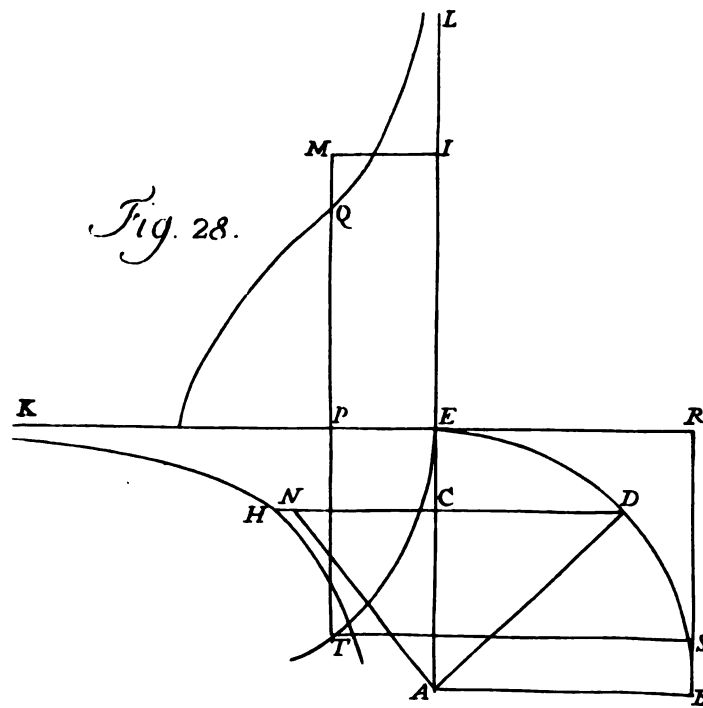

Figure 3: Bernoulli's construction.

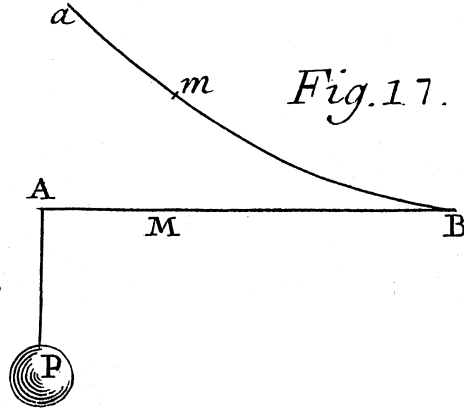

Figure 4: Euler’s drawing of his spiral, from Tabula V of the Additamentum.

The same year, Bernoulli wrote a note containing the integral³ entitled “To find the curve which an attached weight bends into a straight line; that is, to construct the curve $a^2 = sR$ ”.

Quia nominatis abscissa = x , applicata = y , arcu curvæ s , & posita ds constante, radius circuli oscularis, curvedini reciproce proportionalis, est $dxds : -ddy$; habebitur, ex hypothesi, hæc æquatio $-aaddy = sdsdx$

Translated into English (and with slightly modernized notation):

Let us call the abscissa x , the ordinate y , the arclength s , and hold ds constant. Then, the radius of the osculating circle, which is proportional to the reciprocal of the moment, is $dxds/ddy$. Thus, we have, by hypothesis, the equation $-a^2ddy = sdsdx$.

The remainder of the note is a geometric construction of the curve. According to Truesdell [27, p. 109], “it is not enlightening, as it does not reveal that the curve is a spiral, nor is this indicated by his figure.” Nonetheless, it is most definitely the equation for the Euler spiral. This construction is illustrated in Figure 3. The curve of interest is ET , and the others are simply scaffolding from the construction. However, it is not clear from the figure that Bernoulli truly grasped the shape of the curve. Perhaps it is simply the fault the draftsman, but the curve ET is barely distinguishable from a circular arc.

In summary, Bernoulli had written the equation for the curve, but did not draw its true shape, did not compute any values numerically, and did not publish his reasoning for *why* the equation was correct. His central insight was that curvature is additive; more specifically, the curvature of an elastic band under a moment force is its curvature in an unstressed state plus the product of the moment and a coefficient of elasticity. But he never properly published this insight. In editing his work for publication in 1744, his nephew Nicholas I Bernoulli wrote about the equation $s = -a^2/R$, “I have not found this identity established” [27, p. 108].

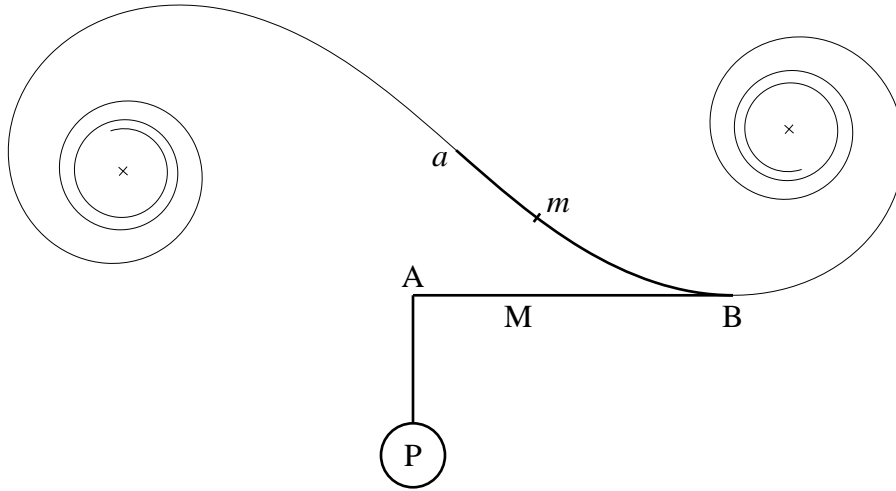

Figure 5: Reconstruction of Euler's Fig. 17, with complete spiral superimposed.

3 Euler characterizes the curve—1744

The passage introducing the Euler spiral appears in section 51 of the *Additamentum*⁴, referring to his Fig. 17, which is reproduced here as Figure 4:

51. Hence the figure amB , which the lamina must have in its natural state, can be determined, so that by the force P , acting in the direction AP , it can be unfolded into the straight line AMB . For letting $AM = s$, the moment of the force acting at the point M will equal Ps , and the radius of curvature at M will be infinite by hypothesis, or $1/R = 0$. Now the arc am in its natural state being equal to s , and the radius of curvature at m being taken as r , because this curve is convex to the axis AB , the quantity r must be made negative. Hence $Ps = Ekk/r$, or $rs = aa$, which is the equation of the curve amB . ([9, §51])

In modern terms (and illustrated by the modern reconstruction of Euler's drawing, Figure 5), the lamina in this case is not straight in its natural (unstressed) state, as is the case in his main investigation of the elastica, but begins with the shape amB . At point B , the curve is held so the tangent is horizontal (i.e. point B is fixed into the wall), and a weight P is suspended from the other end of the lamina, pulling that endpoint down from point A to point a , and overall flattening out the curve of the lamina.

The problem posed is this: what shape must the lamina amB take so that it is flattened into an exactly straight line when the free end is pulled down by weight P ? The answer derived by Euler appeals to the simple theory of moments: the moment at any point M along the (straightened) lamina is the force P times the distance s from A to M .

readily accessible online.

²"Nec non qualem Lamina curvaturam habere debeat, ut ab appenso onere, vel proprio pondere, vel ab utroque simul in rectam extedatur." The translation here is due to Raymond Clare Archibald [2].

³The 1694 original (Latin title "Invenire curvam, quae ab appenso pondere flectitur in rectam; h.e. construere curvam $aa = sz$ " is No. CCXVI of Jacob Bernoulli's *Thoughts, notes, and remarks*. An expanded version was published in slightly expanded form as No. XX of his "Varia Posthuma," which were collected in volume 2 of his *Opera*, published in 1744 (and available online through Google Books)[4, pp. 1084–1086]. Both works are also scheduled to be published in Volume 6 of *Die Werke von Jacob Bernoulli*.

⁴Additamentum 1 to *Methodus inveniendi lineas curvas maximi minimive proprietate gaudentes, sive solutio problematis isoperimetrici lattissimo sensu accepti* [9]. The quotes here are based on Oldfather's 1933 translation [21], with additional monkeying by the author.

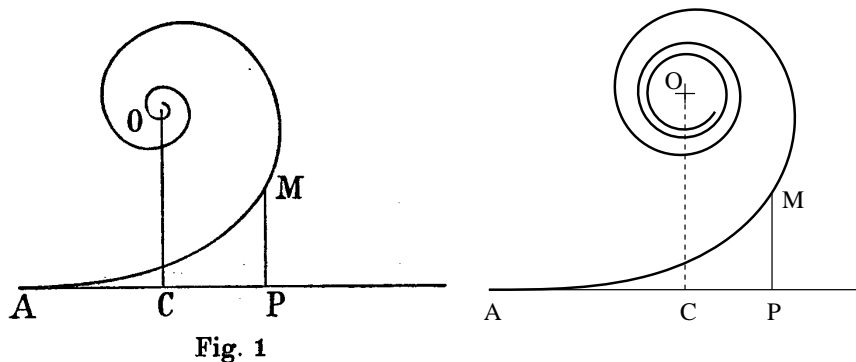

Figure 6: The figure from Euler’s “De valoribus integralium”, with modern reconstruction.

The curvature of the curve resulting from the original shape stressed by force P is equal to the original curvature plus the moment Ps divided by the lamina’s stiffness Ek^2 . Since this resulting curve must be a straight line with curvature zero, the solution for the curvature of the original curve is $\kappa = -Ps(Ek^2)^{-1}$. Euler flips the sign for the curvature and groups all the force and elasticity constants into one constant a for convenience, yielding $1/r = \kappa = s/aa$.

From this intrinsic equation, Euler derives the curve’s quadrature (x and y as a function of the arclength parameter s), giving equations for the modern expression of the curve (formatting in this case preserved from the original):

$$x = \int ds \sin. \frac{ss}{2aa}, \ \& \ y = \int ds \cos. \frac{ss}{2aa} \tag{1}$$

Euler then goes on to describe several properties of the curve, particularly, “Now from the fact that the radius of curvature continuously decreases the greater the arc $am = s$ is taken, it is manifest that the curve cannot become infinite, even if the arc s is taken infinite. Therefore the curve will belong to the class of spirals, in such a way that after an infinite number of windings it will roll up a certain definite point as a center, which point seems very difficult to find from this construction.” [9, §52]

Euler does give a series expansion for the above integral, but in the 1744 publication is not able to analytically determine the coordinates of this limit point, saying “Therefore analysis should gain no small advance, if someone were to discover a method to assign a value, even if only approximate, to the integrals [of Equation 1], in the case where s is infinite; this problem does not seem unworthy for geometers to exercise their strength.”

Euler also derived a series expansion for the integrals [9, §53], which still remains a viable method for computing them for reasonably small s :

$$\begin{aligned} x &= \frac{s^3}{1 \cdot 3 \ b^2} - \frac{s^7}{1 \cdot 2 \cdot 3 \cdot 7 \ b^6} + \frac{s^{11}}{1 \cdot 2 \cdot 3 \cdot 4 \cdot 5 \cdot 11 \ b^{10}} - \frac{s^{15}}{1 \cdot 2 \cdot \dots \cdot 7 \cdot 15 \ b^{14}} + \&c. \\ y &= s - \frac{s^5}{1 \cdot 2 \cdot 5 \ b^4} + \frac{s^9}{1 \cdot 2 \cdot 3 \cdot 4 \cdot 9 \ b^8} - \frac{s^{13}}{1 \cdot 2 \cdot \dots \cdot 6 \cdot 13 \ b^{12}} + \&c. \end{aligned} \tag{2}$$

4 Euler finds the limits—1781

It took him about thirty-eight years to solve the problem of the integral’s limits. In his 1781 “On the values of integrals extended from the variable term $x = 0$ up to $x = \infty$ ”⁵, he finally gave the solution, which he had “recently found by a happy chance and in an exceedingly peculiar manner”, of $x = y = \frac{a}{\sqrt{2}} \sqrt{\frac{\pi}{2}}$. This limit is marked with a cross in Figure 1, as is its mirror-symmetric twin.

⁵“De valoribus integralium a terminus variabilis $x = 0$ usque ad $x = \infty$ extensorum”, presented to the Academy at Petrograd on April 30, 1781, E675 in the Eneström index. Jordan Bell has recently translated this paper into English [10].

The paper references a “Fig. 2”. Unfortunately, the original figure is not easy to track down. The version appearing in Figure 6 is from the 1933 edition of Euler’s collected works. For reference, an accurately plotted reconstruction is shown alongside.

Euler’s technique in finding the limits is to substitute $s^2/2a^2 = v$, resulting in these equivalences (this part of the derivation had already been done in his 1744 *Additamentum* [9, §54]):

$$\begin{aligned}\int_0^\infty \sin \frac{x^2}{2a^2} dx &= \frac{a}{\sqrt{2}} \int_0^\infty \frac{\sin v}{\sqrt{v}} dv \\ \int_0^\infty \cos \frac{x^2}{2a^2} dx &= \frac{a}{\sqrt{2}} \int_0^\infty \frac{\cos v}{\sqrt{v}} dv\end{aligned}\tag{3}$$

To solve these integrals, Euler considers the Gamma function⁶ (which he calls Δ), defined as:

$$\Gamma(z) = \int_0^\infty t^{z-1} e^{-t} dt\tag{4}$$

Through some manipulation, Euler solves a pair of fairly general integrals, of which the limit point of the Euler spiral will be a special case. Assuming $p = r \cos \alpha$, $q = r \sin \alpha$, he derives:

$$\begin{aligned}\int_0^\infty t^{z-1} e^{-px} \cdot \cos qt \, dt &= \frac{\Gamma(z) \cos z\alpha}{r^z} \\ \int_0^\infty t^{z-1} e^{-px} \cdot \sin qt \, dt &= \frac{\Gamma(z) \sin z\alpha}{r^z}\end{aligned}\tag{5}$$

Euler sets $q = 1$, $p = 0$, $z = \frac{1}{2}$ and derives the limit of $\frac{a}{\sqrt{2}} \sqrt{\frac{\pi}{2}}$, which follows straightforwardly from the well-known value $\Gamma(\frac{1}{2}) = \sqrt{\pi}$.

5 Relation to the elastica

The Euler spiral can be considered something of a cousin to the elastica. Both curves were initially described in terms of elasticity problems. In fact, James Bernoulli was responsible for posing both problems, and Leonhard Euler described both curves in detail about fifty years later, in his 1744 *Additamentum* [9, p. 276].

Both curves also appear together frequently in the literature on spline curves, starting from Birkhoff and de Boor’s 1965 survey of nonlinear splines [5], through Mehlum’s work on the Autokon system [17], and Horn’s independent derivation of the rectangular elastica (the “curve of least energy”) [15].

The close relationship between the curves is also apparent in their mathematical formulations. The simplest equation of the elastica is $\kappa = cx$, while that of the Euler spiral is $\kappa = s$ (here, κ represents curvature, x is a cartesian coordinate, and s is the arclength of the curve. This similarity of equation is reflected in the similarity of shape, especially in the region where the arc is roughly parallel to the x axis, as can be seen in Figure 7, which shows both the rectangular elastica and Euler spiral, as well as the “cubic parabola,” showing also the curve that results under the very small angle approximation $\kappa \approx y''$.

Similarly, both curves can be expressed in terms of minimizing a functional. The elastica is the curve that minimizes:

$$E[\kappa(s)] = \int \kappa^2 ds\tag{6}$$

The Euler spiral is one of many solutions that minimizes the L_2 -norm of the *variation* of curvature (known as the MVC, or minimum variation curve) [19]. It is, in fact, the optimal solution when the curvatures (but not the endpoint angles) are constrained.

$$E[\kappa(s)] = \int \left(\frac{d\kappa}{ds}\right)^2 ds\tag{7}$$

It is also the curve that minimizes the L_∞ norm of the curvature variation, subject to endpoint constraints.

⁶Euler published his discovery of the Gamma function in 1729, as *De progressionibus transcendentibus seu quarum termini generales algebraice dari nequeunt*, Eneström index E19.

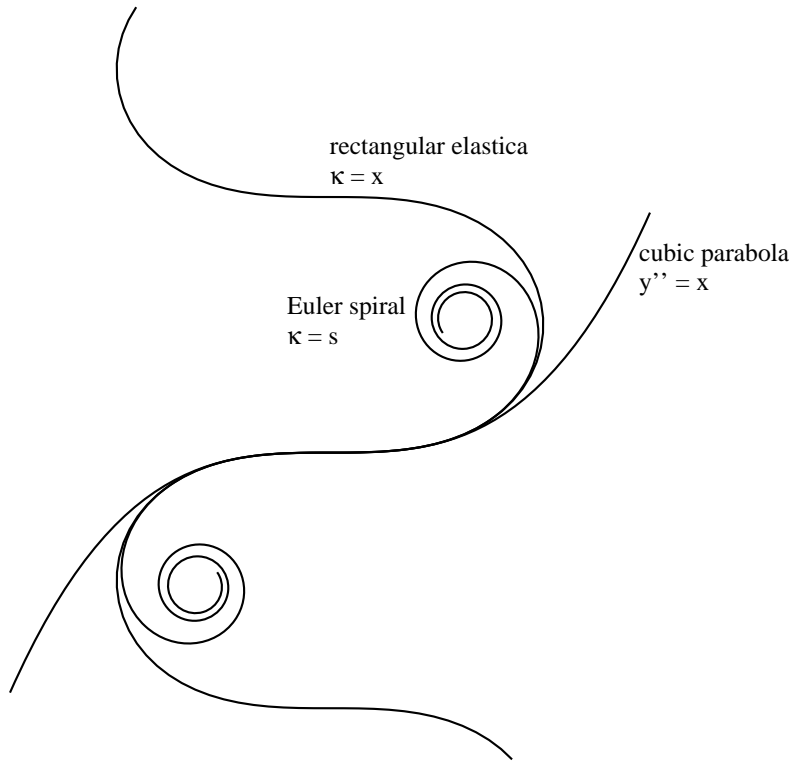

Figure 7: Euler’s spiral, rectangular elastica, and cubic parabola.

6 Fresnel on diffraction problems—1818

Around 1818, Augustin Fresnel considered a problem of light diffracting through a slit, and independently derived integrals equivalent to those defining the Euler spiral⁷. At the time, he seemed to be unaware of the fact that Euler (and Bernoulli) had already considered these integrals, or that they were related to a problem of elastic springs. Later, this correspondence was recognized, as well as the fact that the curves could be used as a graphical computation method for diffraction patterns.

The following presentation of Fresnel’s results loosely follows Preston’s 1901 *The Theory of Light* [23], which is among the earliest English-language accounts of the theory. Another readable account is Houston’s 1915 *Treatise on Light* [16].

Consider a monochromatic light source diffracted through a slit. Based on fundamental principles of wave optics, the wavefront emerging from the slit is the integral of point sources at each point along the slit, shown in Figure 8 as s_0 through s_1 . Assuming the wavelength is λ , the phase ϕ of the light emanating from point s reaching the target on the right is:

$$\phi = \frac{2\pi}{\lambda} \sqrt{x^2 + s^2} \quad (8)$$

Assuming that $s \ll x$, apply a simplifying approximation:

$$\phi \approx \frac{2\pi}{\lambda} \left(x + \frac{1}{2} s^2 \right) \quad (9)$$

⁷A. J. Fresnel, *Mémoire sur la diffraction de la lumière*, Annales de Chimie et de Physique, t.x., 288 1819. Henry Crew published a translation into English in 1900 [11]

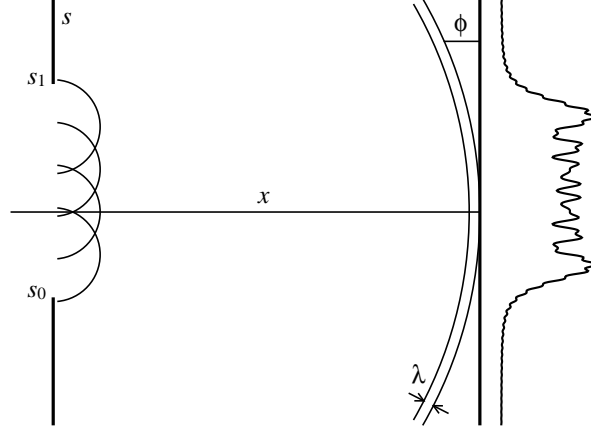

Figure 8: Diffraction through a slit.

Again assuming $s \ll x$, the intensity of the wave can be considered constant for all $s_0 < s < s_1$. Dropping the term including x (it represents the phase of the light incident on the target, but doesn't affect total intensity), and choosing units arbitrarily to simplify constants, assume $\lambda = \frac{1}{2}$, and then the intensity incident on the target is:

$$I = \left[\int_{s_0}^{s_1} \cos \phi ds \right]^2 + \left[\int_{s_0}^{s_1} \sin \phi(s) ds \right]^2 = \left[\int_{s_0}^{s_1} \cos \frac{\pi}{2} s^2 ds \right]^2 + \left[\int_{s_0}^{s_1} \sin \frac{\pi}{2} s^2 ds \right]^2 \quad (10)$$

The indefinite integrals needed to compute this intensity are best known as the *Fresnel integrals*:

$$\begin{aligned} S(z) &= \int_0^z \sin \left(\frac{\pi t^2}{2} \right) dt \\ C(z) &= \int_0^z \cos \left(\frac{\pi t^2}{2} \right) dt \end{aligned} \quad (11)$$

Choosing $a = 1/\sqrt{\pi}$, these integrals are obviously equivalent to the formula for the Cartesian coordinates of the Euler spiral, Equation 1. The choice of scale factor gives a simpler limit: $S(z) = C(z) = 0.5$ as $z \rightarrow \infty$. Fresnel gives these limits, but does not justify the result [11, p. 124].

Given these integrals, the formula for intensity, Equation 10 can be rewritten simply as:

$$I = (S(s_1) - S(s_0))^2 + (C(s_1) - C(s_0))^2 \quad (12)$$

Fresnel included in his 1818 publication a table of fifty values (with equally spaced s) to four decimal places.

Alfred Marie Cornu plotted the spiral accurately in 1874 [7] and proposed its use as a graphical computation technique for diffraction problems. His main insight is that the intensity I is simply the square of the Euclidean distance between the two points on the Euler spiral at arclength s_0 and s_1 . Cornu observes the same principle as Bernoulli's proposal of the formula for the integrals: *Le rayon de courbure est en raison inverse de l'arc* (the radius of curvature is inversely proportional to arclength), but he, like Fresnel, also seems unaware of Euler's prior investigation of the integral, or of the curve.

Today, it is common to use complex numbers to obtain a more concise formulation of the Fresnel integrals, reflecting the intuitive understanding of the propagation of light as a complex-valued wave:

$$C(z) + iS(z) = \int_0^z e^{i\frac{\pi}{2}t^2} dt \quad (13)$$

Even though Euler anticipated the important mathematical results, the phrase "spiral of Cornu" became popular. At the funeral of Alfred Cornu on April 16, 1902, Henri Poincaré had these glowing words: "Also, when addressing the study of diffraction, he had quickly replaced an unpleasant multitude of hairy integral formulas with a single harmonious figure, that the eye follows with pleasure and where

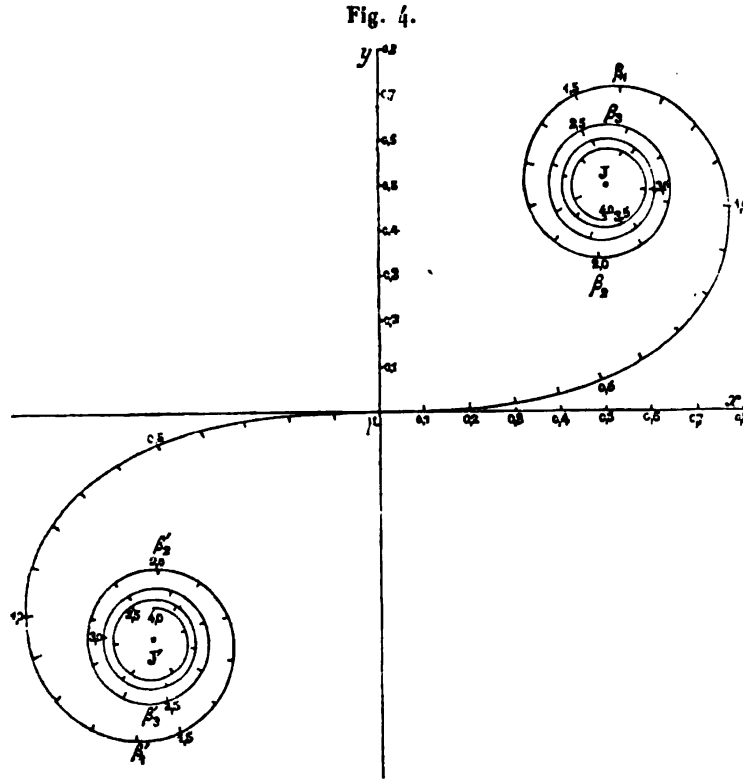

Figure 9: Cornu's plot of the Fresnel integrals.

the spirit moves without effort.” Elaborating further in his sketch of Cornu in his 1910 *Savants et écrivains*), “Today, everyone, to predict the effect of an arbitrary screen on a beam of light, makes use of the spiral of Cornu.” (translations from original French mine).

Since apparently two names were not adequate, Ernesto Cesàro around 1886 dubbed the curve “clothoid”, after Clotho ($K\lambda\omega\theta\acute{\omega}$), the youngest of the three Fates of Greek mythology, who spun the threads of life, winding them around her distaff—since the curve spins or twists about its asymptotic points. Today, judging from the number of documents retrieved by keyword from an Internet search engine, the term “clothoid” is by far the most popular⁸. However, as Archibald wrote in 1917 [2], by modern standards of attribution, it is clear that the proper name for this beautiful curve is the Euler spiral, and that is the name used here throughout.

7 Talbot's railway transition spiral—1890

The third completely independent discovery of the Euler spiral is in the context of designing railway tracks to provide a smooth riding experience. Over the course of the 19th century, the need for a track shape with gradually varying curvature became clear. William Rankine, in his *Manual of Civil Engineering* [24, p. 651], gives Mr. Gravatt credit for the first such curve, about 1828 or 1829, based on a sine curve. The elastica makes another appearance, in a proposal about 1842 by William Froude to use circles for most of the curve, but “a curve approximating the elastic curve, for the purpose of making the change of curvature by degrees.”

Charles Crandall [8, p. 1] gives priority for the “true transition curve” to Ellis Holbrook, in the

⁸As of 25 Aug 2008, Google search reports 17,700 results for “clothoid”, 5,660 hits for “Cornu spiral”, 935 hits for “Euler spiral”, and 17,800 for “Fresnel integral”.

Railroad Gazette, Dec. 3, 1880. Arthur Talbot was also among the first to approach the problem mathematically, and derived exactly the same integrals as Bernoulli and Fresnel before him. His introduction to “The Railway Transition Spiral” [26] describes the problem and his solution articulately:

A transition curve, or easement curve, as it is sometimes called, is a curve of varying radius used to connect circular curves with tangents for the purpose of avoiding the shock and disagreeable lurch of trains, due to the instant change of direction and also to the sudden change from level to inclined track. The primary object of the transition curve, then, is to effect smooth riding when the train is entering or leaving a curve.

The generally accepted requirement for a proper transition curve is that the degree-of-curve shall increase gradually and uniformly from the point of tangent until the degree of the main curve is reached, and that the super-elevation⁹ shall increase uniformly from zero at the tangent to the full amount at the connection with the main curve and yet have at any point the appropriate super-elevation for the curvature. In addition to this, an acceptable transition curve must be so simple that the field work may be easily and rapidly done, and should be so flexible that it may be adjusted to meet the varied requirements of problems in location and construction.

Without attempting to show the necessity or the utility of transition curves, this paper will consider the principles and some of the applications of one of the best of these curves, the railway transition spiral.

The Transition Spiral is a curve whose degree-of-curve increases directly as the distance along the curve from the point of spiral.

Thus, we have yet another concise statement of what Bernoulli and Euler wrote as $rs = aa$.

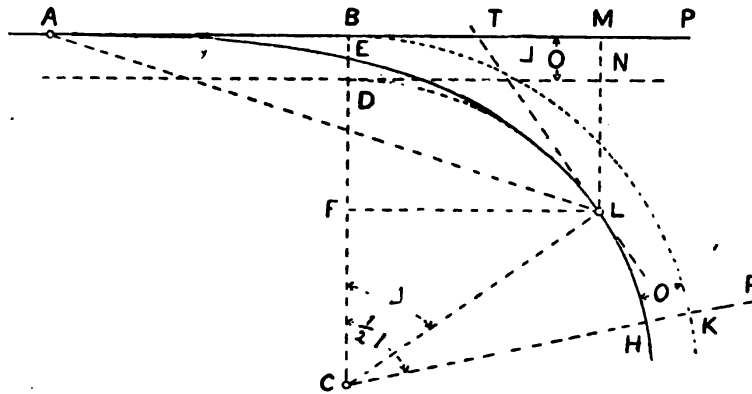

Figure 10: Talbot’s Railway Transition Spiral.

In his introductory figure (here reproduced as Figure 10), Talbot shows the spiral connecting a straight section tangent to point A to a circular arc LH (of which DLH continues the arc, and C is the center of the circle). The remainder of the paper consists of many tables of values for this spiral, as well as examples of its application to specific problems.

Talbot derives the basic equations in terms of the angle of direction (he uses Δ , apparently standing for “degrees”, having already used up θ to represent the angle BAL ; also, L is arclength, not to be confused with point L in the figure): $\Delta = \frac{1}{2}aL^2$ [26, p. 9]. He then expresses the x and y coordinates in terms of the simple equations $dy = ds \sin \Delta$ and $dx = ds \cos \Delta$, quickly moving to a series expansion for easy numerical evaluation, then integrating. In particular, Talbot writes [26, p.10]:

$$\begin{aligned} y &= .291 a L^3 - .00000158 a^3 L^7 \dots \\ x &= 100L - .000762 a^2 L^5 + .0000000027 a^4 L^9 \dots \end{aligned} \tag{14}$$

⁹Super-elevation is the difference in elevation between the outer and inner rails, banking a moving train to reduce the lateral acceleration felt by passengers.

Aside from a switch of x and y , and a change of constants representing actual physical units used in railroad engineering, these equations are effectively identical to those derived in Euler’s 1744 *Additamentum*, see Equation 2.

Obviously, Talbot was unaware of Euler’s original work, or of the identity of his spiral to the original problem in elasticity. Similarly, Archibald did not cite any of the railroad work in his otherwise extremely complete 1917 survey [2]. The earliest published connection between the railway transition spiral and the clothoid I could find is in a 1922 book by Arthur Higgins [14], where it is also referred to as the “Glover’s spiral”, a reference to a 1900 derivation by James Glover [12] of results similar to Talbot’s, but with considerably more mathematical notation.

8 Mathematical properties

Euler’s spiral and the Fresnel integrals that generate it have a number of interesting mathematical properties. This section presents a selection.

The Fresnel integrals are closely related to the error function [1, p.301], §7.3.22:

$$C(z) + iS(z) = \frac{1+i}{2} \operatorname{erf}\left(\frac{\sqrt{\pi}}{2}(1-i)z\right) \quad (15)$$

The Fresnel integrals can also be considered a special case of the confluent hypergeometric function [1, p.301], §7.3.25:

$$C(z) + iS(z) = z {}_1F_1\left(\frac{1}{2}; \frac{3}{2}; i\frac{\pi}{2}z^2\right) \quad (16)$$

The confluent hypergeometric function ${}_1F_1(a; b; z)$ is defined thus:

$${}_1F_1(a; b; z) = 1 + \frac{a}{b}z + \frac{a(a+1)}{b(b+1)}\frac{z^2}{2!} + \dots = \sum_{k=0}^{\infty} \frac{(a)_k}{(b)_k} \frac{z^k}{k!}, \quad (17)$$

where $(a)_k$ and $(b)_k$ are *Pochhammer symbols*, also known as the “rising factorial,” defined:

$$(a)_k = \frac{(a+k-1)!}{(a-1)!} = \frac{\Gamma(a+k)}{\Gamma(a)} \quad (18)$$

Due to these equivalences, the Fresnel integrals are often considered part of a larger family of related “special functions” containing the Gamma function, erf, Bessel functions, and others.

9 Use as an interpolating spline

Several systems and publications have proposed the use of the Euler spiral as an interpolating spline primitive, but for some reason it has not become popular. Perhaps one reason is that many authors seem to consider the Euler spiral nothing but an approximation to a “true” spline based on the elastica.

An early reference to the Euler spiral for use as an interpolating spline is Birkhoff and de Boor’s 1965 survey of both linear and nonlinear splines [5]. There, they present the rectangular elastica as the curve simulating the mechanical spline, but also point out that an exact simulation of this curve is not “particularly desirable.” As an alternative, they suggest that “they approximate equally well to Hermite interpolation by segments of Euler’s spirals” [5, p. 172], and cite Archibald [2] as their source.

Probably the earliest actual application of Euler’s spiral for splines was in the Autokon system, developed in the beginning of the 1960’s. According to Even Mehlum [18], early versions of Autokon used the KURGLA 1 algorithm, which was a numerical approximation to the elastica. Later versions used Euler’s spiral, having derived it as a small curvature approximation to the elastica equation. (Note that KURGLA 1 is based on the elastica, but not quite the same as a true minimal energy curve (MEC), as the curve segments can take elastica forms other than the rectangular elastica). Mehlum writes: “There is hardly any visible difference between the curves the two algorithms produce, but KURGLA 2 is preferred because of its better computational economy. There is also a question of stability in the KURGLA 1 version if the total arc length is not kept under control. This question disappears in the case of KURGLA 2.”

Mehlum published both KURGLA algorithms in 1974 [17]. It is fairly clear that he considered the Euler spiral an approximation to true splines based on the elastica. He writes, “In Section 5 we make a ‘mathematical approximation’ in addition to the numerical, which makes the resulting curves of Section 5 slightly different from those of Section 4 [which is based on the elastica as a primitive]. The difference is, however, not visible in practical applications.”

The 1974 publication notes that the spline solution with linear variation of curvature and G^2 continuity is a piecewise Cornu spiral, and that the Fresnel integrals represent the Cartesian coordinates for this curve, but does not cite sources for these facts.

Mehlum’s numerical techniques are based on approximating the Euler spiral using a sequence of stepped circular arcs of linearly increasing curvature.

Stoer [25] writes that the Euler spiral spline can be considered an approximation to the “true” problem of finding a minimal energy spline. His results are broadly similar to Mehlum’s, but he presents his algorithms in considerably more detail, including a detailed construction of a band-diagonal Jacobian matrix. He also presents an application of Euler spirals as a smoothing (approximating), rather than interpolating spline.

Stoer also brings up the point that there may be many discrete solutions to the interpolating spline problem, each G^2 continuous and piecewise Euler spiral, based on higher winding numbers. From these, he chooses the solution minimizing the total bending energy as the “best” one.

Later, Coope [6] again presents the “spiral spline” as a good approximation to the minimum energy curve, gives a good Newton approximation method with band-diagonal matrices for globally solving the splines, and notes that “for sensible end conditions and appropriately calculated chord angles convergence always occurs.” A stronger convergence result is posed as an open problem.

10 Efficient computation

Throughout the history of the Euler spiral, a major focus of mathematical investigation is to compute values of the integral efficiently. Fresnel, in particular, devotes many pages to approximate formulas for the definite integral when the limits of integration are close together [11], and used these techniques to produce his table. Many subsequent researchers throughout the 19th century refined these techniques and the resulting tables, including Knochenhauer, Cauchy, Gilbert, Peters, Ignatowsky, Lommel and Peters (see [2] for more detail and citations on these results).

Today, the problem can be considered solved. At least two published algorithms provide accurate results in time comparable to that needed to evaluate ordinary trigonometric functions.

One technique is that of the Cephes library [20], which uses a highly numerical technique, splitting the function into two ranges. For values of $s < 1.6$, a simple rational Chebyshev polynomial gives the answer with high precision. For the section turning around the limit point, a similar polynomial perturbs this approximation (valid for $z \gg 1$) into an accurate value:

$$C(z) + iS(z) \approx \frac{1+i}{2} - \frac{i}{\pi z} e^{i\frac{\pi}{2}z^2} \quad (19)$$

Numerical Recipes [22] uses a similar technique to split the range. For the section $s < 1.5$ near the inflection point, the series given by Euler in 1744 (Equation 2) accurately computes the function. For the section spiraling around the limit point, the recipe calls for a continued fraction based on the erf function. Thanks to equivalences involving e^{iz^2} , this solution also converges to Equation 19 as $z \rightarrow \infty$ [22, p. 255].

Thus, the Fresnel integrals can be considered an ordinary “special function”, and the coordinates of the Euler spiral can be efficiently computed without fear of requiring significant resources.

References

- [1] Milton Abramowitz and Irene A. Stegun. *Handbook of Mathematical Functions with Formulas, Graphs, and Mathematical Tables*. Dover, New York, ninth Dover printing, tenth GPO printing edition, 1964.

- [2] Raymond Clare Archibald. Euler integrals and Euler’s spiral. *American Mathematical Monthly*, 25(6):276–282, June 1917.
- [3] James Bernoulli. *Jacobi Bernoulli, Basiliensis, Opera*, volume 1. Cramer & Philibert, Geneva, 1744.
- [4] James Bernoulli. *Jacobi Bernoulli, Basiliensis, Opera*, volume 2. Cramer & Philibert, Geneva, 1744.
- [5] Garrett Birkhoff and Carl R. de Boor. Piecewise polynomial interpolation and approximation. *Proc. General Motors Symp. of 1964*, pages 164–190, 1965.
- [6] Ian D. Coope. Curve interpolation with nonlinear spiral splines. *IMA Journal of Numerical Analysis*, 13(3):327–341, 1993.
- [7] Marie Alfred Cornu. Méthode nouvelle pour la discussion des problèmes de diffraction dans le cas d’une onde cylindrique. *Journal de Physique théorique et appliquée*, pages 5–15, 1874.
- [8] Charles Lee Crandall. *The Transition Curve*. Wiley, 1893.
- [9] Leonhard Euler. *Methodus inveniendi lineas curvas maximi minimive proprietate gaudentes, sive solutio problematis isoperimetrici lattissimo sensu accepti*, chapter Additamentum 1. eulerarchive.org E065, 1744.
- [10] Leonhard Euler. On the values of integrals extended from the variable term $x = 0$ up to $x = \infty$, 2007. Translation into English by Jordan Bell.
- [11] Augustin Jean Fresnel. Memoir on the diffraction of light. In Henry Crew, editor, *The Wave Theory of Light*, pages 79–144. American Book Company, 1900.
- [12] James Glover. Transition curves for railways. In *Minutes of Proceedings of the Institution of Civil Engineers*, volume 140, pages 161–179, 1900.
- [13] Alfred Gray. *Modern Differential Geometry of Curves and Surfaces with Mathematica*, chapter 3.5, Clothoids, pages 64–66. CRC Press, Boca Raton, FL, 2nd edition, 1997.
- [14] Arthur Lovat Higgins. *The Transition Spiral and Its Introduction to Railway Curves*. Van Nostrand, 1922.
- [15] B. K. P. Horn. The curve of least energy. Technical Report A.I. Memo. No. 612, MIT AI Lab, January 1981.
- [16] Robert Alexander Houstoun. *A Treatise on Light*. Longmans, Green and Co., 1915.
- [17] Even Mehlum. Nonlinear splines. *Computer Aided Geometric Design*, pages 173–205, 1974.
- [18] Even Mehlum. Appell and the apple (nonlinear splines in space). In M. Dæhlen, T. Lyche, and L. L. Schumaker, editors, *Mathematical Methods for Curves and Surfaces: Ulvik, Norway*. Vanderbilt University Press, 1994.
- [19] Henry P. Moreton and Carlo H. Séquin. Scale-invariant minimum-cost curves: Fair and robust design implements. *Computer Graphics Forum*, 12:473–484, 1993.
- [20] Stephen L. Moshier. *Methods and Programs for Mathematical Functions*. Prentice Hall, 1989.
- [21] W. A. Oldfather, C. A. Ellis, and Donald M. Brown. Leonhard Euler’s elastic curves. *Isis*, 20(1):72–160, November 1933.
- [22] William H. Press, Saul A. Teukolsky, William T. Vetterling, and Brian P. Flannery. *Numerical Recipes in C*. Cambridge University Press, 2nd edition, 1992.
- [23] Thomas Preston and Charles Jasper Joly. *The Theory of Light*. Macmillan, 1901.
- [24] William John Macquorn Rankine. *A Manual of Civil Engineering*. Charles Griffin, 17th edition, 1889.
- [25] Josef Stoer. Curve fitting with clothoidal splines. *J. Res. Nat. Bur. Standards*, 87(4):317–346, 1982.
- [26] Arther N. Talbot. *The Railway Transition Spiral*. U. Illinois, 1899. Reprinted from The Technograph No. 13.
- [27] C. Truesdell. *The Rational Mechanics of Flexible or Elastic Bodies: 1638–1788*. Birkhäuser, 1960. Introduction to Leonhardi Euleri Opera Omnia Vol X et XI, Series 2.